

Common side reactions with (S)-2-Pentanamine and how to avoid them

Author: BenchChem Technical Support Team. **Date:** April 2026

Compound of Interest

Compound Name: 2-Pentanamine, (2S)-

CAS No.: 54542-13-1

Cat. No.: B3181134

[Get Quote](#)

Technical Support Center: (S)-2-Pentanamine

Welcome to the technical support center for (S)-2-Pentanamine. This resource is designed for researchers, scientists, and drug development professionals to troubleshoot common side reactions and provide guidance on their avoidance.

Frequently Asked Questions (FAQs)

Q1: What are the most common side reactions observed when using (S)-2-Pentanamine?

A1: The most frequently encountered side reactions with (S)-2-Pentanamine are:

- **Over-alkylation:** Due to the nucleophilic nature of the primary amine, it can react with alkylating agents multiple times, leading to the formation of secondary and tertiary amines as byproducts. The secondary amine formed is often more nucleophilic than the primary amine, exacerbating this issue.
- **Formation of Diastereomers:** When (S)-2-Pentanamine is reacted with other chiral molecules, a mixture of diastereomers can be formed. Since diastereomers have different

physical properties, this can complicate purification and analysis.[\[1\]](#)[\[2\]](#)

- **Elimination Reactions:** In reactions with alkyl halides, (S)-2-Pentanamine can act as a base, leading to competing elimination (E2) reactions, which produce alkenes as side products instead of the desired substitution (SN2) product.[\[3\]](#)[\[4\]](#)[\[5\]](#)[\[6\]](#)[\[7\]](#)
- **Air Oxidation and Hygroscopicity:** Like many amines, (S)-2-Pentanamine can be sensitive to air oxidation and is hygroscopic, meaning it can absorb moisture from the atmosphere. This can lead to degradation of the material and affect reaction outcomes.

Troubleshooting Guides

Issue 1: Over-alkylation leading to a mixture of secondary and tertiary amines.

Question: I am trying to perform a mono-alkylation on (S)-2-Pentanamine, but I am consistently getting a mixture of the desired primary amine, as well as the di- and tri-alkylated products.

How can I improve the selectivity for mono-alkylation?

Answer: Over-alkylation is a common challenge with primary amines. Here are several strategies to promote mono-alkylation:

Strategies to Avoid Over-alkylation:

- **Use of a Large Excess of the Amine:** Employing a significant excess of (S)-2-Pentanamine relative to the alkylating agent can statistically favor the mono-alkylation product.
- **Slow Addition of the Alkylating Agent:** Adding the alkylating agent slowly to the reaction mixture at a low temperature can help to control the reaction rate and reduce the likelihood of the initially formed secondary amine reacting further.
- **Use of Protecting Groups:** A reliable method to ensure mono-alkylation is to use a protecting group for the amine. The amine is first protected, then alkylated, and finally deprotected to yield the desired secondary amine. Common protecting groups for amines include Boc (tert-butyloxycarbonyl) and Cbz (carboxybenzyl).[\[8\]](#)[\[9\]](#)[\[10\]](#)[\[11\]](#)

Experimental Protocol: Mono-alkylation via a Boc-Protected Intermediate

- Protection:
 - Dissolve (S)-2-Pentanamine (1 equivalent) in a suitable solvent such as dichloromethane (DCM) or tetrahydrofuran (THF).
 - Add di-tert-butyl dicarbonate (Boc)₂O (1.1 equivalents) and a base such as triethylamine (TEA) or diisopropylethylamine (DIPEA) (1.2 equivalents).
 - Stir the reaction at room temperature for 2-4 hours, monitoring by TLC or LC-MS until the starting amine is consumed.
 - Work up the reaction by washing with aqueous acid (e.g., 1M HCl), followed by saturated aqueous sodium bicarbonate, and finally brine. Dry the organic layer over anhydrous sodium sulfate, filter, and concentrate under reduced pressure to obtain the Boc-protected amine.
- Alkylation:
 - Dissolve the Boc-protected amine in an aprotic polar solvent like THF or DMF.
 - Cool the solution to 0 °C and add a strong base such as sodium hydride (NaH) (1.2 equivalents) portion-wise.
 - Allow the mixture to stir at 0 °C for 30 minutes.
 - Add the alkylating agent (e.g., an alkyl halide) (1.1 equivalents) dropwise.
 - Allow the reaction to warm to room temperature and stir until completion.
 - Quench the reaction carefully with water and extract the product with a suitable organic solvent.
 - Purify the product by column chromatography.
- Deprotection:
 - Dissolve the alkylated Boc-protected amine in a solvent such as DCM or dioxane.

- Add a strong acid, such as trifluoroacetic acid (TFA) or hydrochloric acid (HCl) in dioxane.
- Stir at room temperature until the deprotection is complete (monitored by TLC or LC-MS).
- Remove the solvent and excess acid under reduced pressure to obtain the desired mono-alkylated amine salt.

Logical Workflow for Avoiding Over-alkylation

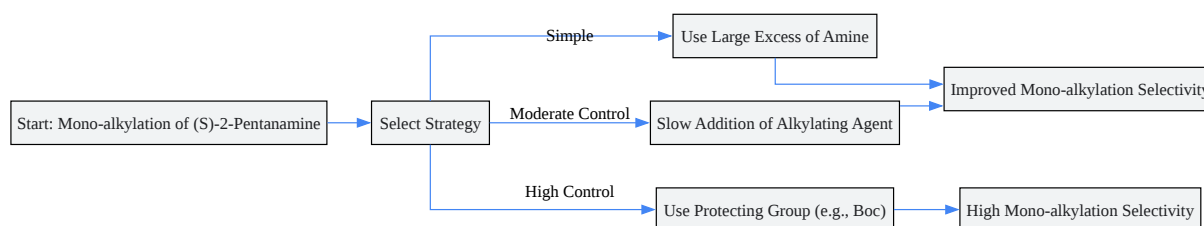

[Click to download full resolution via product page](#)

Caption: Strategies to control the mono-alkylation of primary amines.

Issue 2: Formation of Diastereomers.

Question: I am reacting (S)-2-Pentanamine with a chiral electrophile, and I am obtaining a mixture of diastereomers that are difficult to separate. How can I control the diastereoselectivity of this reaction?

Answer: The formation of diastereomers is expected when two chiral centers are present in the product. The ratio of these diastereomers is influenced by steric and electronic factors in the transition state.

Strategies to Control Diastereoselectivity:

- **Chiral Auxiliaries:** The use of a chiral auxiliary on either the amine or the electrophile can create a more ordered transition state, leading to a higher diastereomeric excess (d.e.).
- **Reaction Conditions:** Temperature, solvent, and the presence of Lewis acids can significantly influence the diastereomeric ratio. Lowering the reaction temperature often improves selectivity.
- **Reagent Control:** The choice of reagents can also play a crucial role. For example, in reductive amination, the choice of reducing agent can affect the stereochemical outcome.

Quantitative Data on Diastereoselectivity (Illustrative)

While specific data for (S)-2-Pentanamine is not readily available in the literature, the following table illustrates how reaction conditions can affect the diastereomeric ratio in a generic reaction between a chiral amine and a chiral ketone.

Entry	Reducing Agent	Temperature (°C)	Solvent	Diastereomeric Ratio (A:B)
1	NaBH ₄	25	Methanol	60:40
2	NaBH(OAc) ₃	0	Dichloromethane	85:15
3	L-Selectride®	-78	Tetrahydrofuran	>95:5

Experimental Protocol: Diastereoselective Reductive Amination

- **Imine Formation:**
 - Dissolve the chiral ketone (1 equivalent) and (S)-2-Pentanamine (1.1 equivalents) in a suitable solvent (e.g., dichloromethane or 1,2-dichloroethane).
 - Add a dehydrating agent, such as anhydrous magnesium sulfate or molecular sieves, to remove the water formed during the reaction.
 - Stir the mixture at room temperature until imine formation is complete (monitored by ¹H NMR or IR spectroscopy).

- Reduction:
 - Cool the reaction mixture to the desired temperature (e.g., 0 °C or -78 °C).
 - Slowly add the chosen reducing agent (e.g., sodium triacetoxyborohydride).
 - Stir the reaction until the imine is fully reduced.
 - Quench the reaction with a saturated aqueous solution of sodium bicarbonate.
 - Separate the organic layer, wash with brine, dry over anhydrous sodium sulfate, and concentrate.
 - Determine the diastereomeric ratio using ^1H NMR spectroscopy or chiral HPLC.

Signaling Pathway for Diastereomer Formation

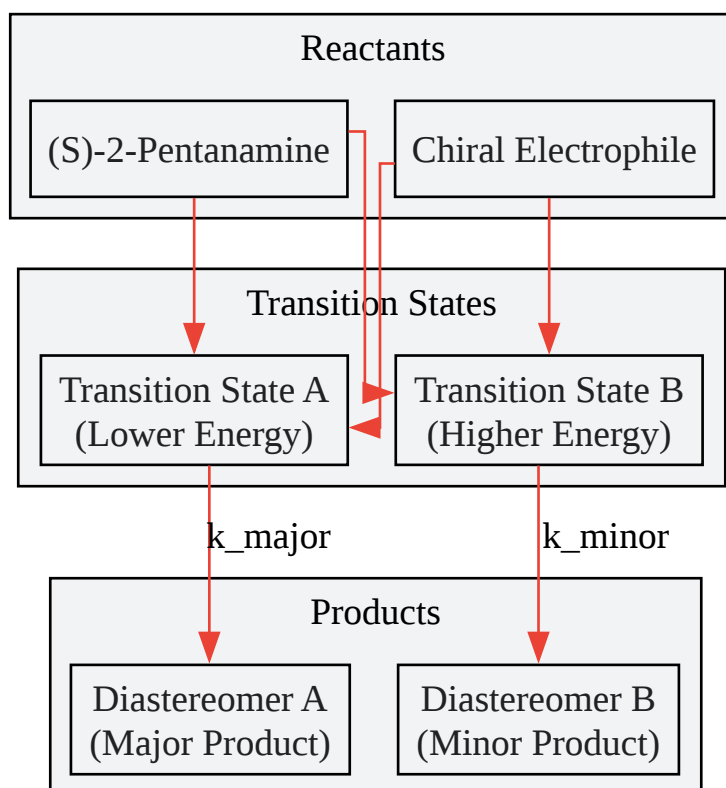

[Click to download full resolution via product page](#)

Caption: Energy profile illustrating the formation of diastereomers.

Issue 3: Competing Elimination (E2) Reactions.

Question: My substitution reaction with (S)-2-Pentanamine and a secondary alkyl halide is producing a significant amount of an alkene byproduct. How can I favor the SN2 pathway over the E2 pathway?

Answer: The competition between substitution (SN2) and elimination (E2) is a common issue, especially with secondary and sterically hindered primary alkyl halides. (S)-2-Pentanamine can act as both a nucleophile (favoring SN2) and a base (favoring E2).

Factors Influencing the SN2/E2 Competition:

- **Substrate Structure:** Steric hindrance around the reaction center of the alkyl halide disfavors the SN2 pathway and promotes the E2 pathway.^{[6][12][13]}
- **Strength and Steric Hindrance of the Base/Nucleophile:** Strong, sterically hindered bases favor E2, while strong, non-hindered nucleophiles favor SN2. (S)-2-Pentanamine is a moderately hindered primary amine.
- **Temperature:** Higher temperatures generally favor elimination reactions over substitution reactions.^[14]
- **Solvent:** Polar aprotic solvents (e.g., DMSO, DMF, acetone) tend to favor SN2 reactions, while polar protic solvents (e.g., ethanol, water) can favor both but may promote E2 if the amine is strongly basic.^[15]

Quantitative Data on SN2 vs. E2 (Illustrative)

The following table provides an illustrative example of how reaction conditions can influence the product distribution for the reaction of a secondary alkyl bromide with a primary amine.

Entry	Amine	Solvent	Temperature (°C)	SN2:E2 Ratio
1	n-Butylamine	DMSO	25	90:10
2	n-Butylamine	Ethanol	78	60:40
3	t-Butylamine	DMSO	25	20:80
4	n-Butylamine	Ethanol	25	75:25

Experimental Protocol to Favor SN2:

- Solvent and Temperature:
 - Choose a polar aprotic solvent such as acetone, acetonitrile, or DMF.
 - Run the reaction at a lower temperature, for example, room temperature or slightly below.
- Reagent Stoichiometry:
 - Use a slight excess of (S)-2-Pentanamine (1.1-1.5 equivalents) to ensure the alkyl halide is the limiting reagent.
- Reaction Setup:
 - In a round-bottom flask, dissolve the alkyl halide in the chosen polar aprotic solvent.
 - Add (S)-2-Pentanamine to the solution.
 - Stir the reaction mixture at the selected temperature and monitor its progress by TLC or GC-MS.
- Work-up and Analysis:
 - Once the reaction is complete, quench with water and extract the product with an organic solvent.
 - Wash the organic layer with brine, dry over anhydrous sodium sulfate, and concentrate.

Question: What are the recommended storage and handling procedures for (S)-2-Pentanamine?

Answer:

- Storage: (S)-2-Pentanamine should be stored in a tightly sealed container under an inert atmosphere (e.g., argon or nitrogen) to prevent oxidation and moisture absorption.[16] It is best stored in a cool, dry, and well-ventilated area away from incompatible substances such as strong oxidizing agents and acids.[16]
- Handling: Due to its potential volatility and hygroscopic nature, it should be handled in a well-ventilated fume hood. Use appropriate personal protective equipment (PPE), including gloves, safety glasses, and a lab coat. Avoid inhalation of vapors and contact with skin and eyes. In case of a spill, absorb with an inert material and dispose of it according to local regulations.

Need Custom Synthesis?

BenchChem offers custom synthesis for rare earth carbides and specific isotopic labeling.

Email: info@benchchem.com or [Request Quote Online](#).

References

- [1. pharmacy180.com](https://www.pharmacy180.com) [[pharmacy180.com](https://www.pharmacy180.com)]
- [2. chem.libretexts.org](https://chem.libretexts.org) [chem.libretexts.org]
- [3. Understanding E2 versus SN2 Competition under Acidic and Basic Conditions - PMC](https://pubmed.ncbi.nlm.nih.gov/123456789/) [[pmc.ncbi.nlm.nih.gov](https://pubmed.ncbi.nlm.nih.gov/123456789/)]
- [4. chem.libretexts.org](https://chem.libretexts.org) [chem.libretexts.org]
- [5. 11.12 A Summary of Reactivity: SN1, SN2, E1, E1cB, and E2 – Organic Chemistry: A Tenth Edition – OpenStax adaptation 1](https://openstax.org/r/organic-chemistry-10e) [[ncstate.pressbooks.pub](https://openstax.org/r/organic-chemistry-10e)]
- [6. masterorganicchemistry.com](https://www.masterorganicchemistry.com) [[masterorganicchemistry.com](https://www.masterorganicchemistry.com)]
- [7. youtube.com](https://www.youtube.com) [[youtube.com](https://www.youtube.com)]
- [8. youtube.com](https://www.youtube.com) [[youtube.com](https://www.youtube.com)]
- [9. youtube.com](https://www.youtube.com) [[youtube.com](https://www.youtube.com)]

- [10. youtube.com \[youtube.com\]](https://www.youtube.com)
- [11. m.youtube.com \[m.youtube.com\]](https://m.youtube.com)
- [12. Enzymatic Routes for Chiral Amine Synthesis: Protein Engineering and Process Optimization - PMC \[pmc.ncbi.nlm.nih.gov\]](https://pubmed.ncbi.nlm.nih.gov/)
- [13. pubs.acs.org \[pubs.acs.org\]](https://pubs.acs.org)
- [14. researchgate.net \[researchgate.net\]](https://www.researchgate.net)
- [15. researchgate.net \[researchgate.net\]](https://www.researchgate.net)
- [16. diplomatacomercial.com \[diplomatacomercial.com\]](https://www.diplomatacomercial.com)
- To cite this document: BenchChem. [Common side reactions with (S)-2-Pentanamine and how to avoid them]. BenchChem, [2026]. [Online PDF]. Available at: [\[https://www.benchchem.com/product/b3181134/docs#common-side-reactions-with-s-2-pentanamine-and-how-to-avoid-them\]](https://www.benchchem.com/product/b3181134/docs#common-side-reactions-with-s-2-pentanamine-and-how-to-avoid-them)

Disclaimer & Data Validity:

The information provided in this document is for Research Use Only (RUO) and is strictly not intended for diagnostic or therapeutic procedures. While BenchChem strives to provide accurate protocols, we make no warranties, express or implied, regarding the fitness of this product for every specific experimental setup.

Technical Support: The protocols provided are for reference purposes. Unsure if this reagent suits your experiment?

Need Industrial/Bulk Grade? [Request Custom Synthesis Quote](#)

BenchChem

Our mission is to be the trusted global source of essential and advanced chemicals, empowering scientists and researchers to drive progress in science and industry.

Contact

Address: 3281 E Guasti Rd
Ontario, CA 91761, United States
Phone: (601) 213-4426
Email: info@benchchem.com

Contact our Ph.D. Support Team for a compatibility check