

# A Researcher's Guide to the Reproducible Synthesis of Substituted Fluoroanilines

**Author:** BenchChem Technical Support Team. **Date:** April 2026

## Compound of Interest

Compound Name: 2-(2-Cyclohexylethoxy)-5-fluoroaniline

CAS No.: 946774-69-2

Cat. No.: B3173238

[Get Quote](#)

An In-depth Technical Comparison of Synthetic Protocols for Medicinal and Process Chemistry

Substituted fluoroanilines are privileged structural motifs in modern drug discovery and development. Their unique physicochemical properties, imparted by the strategic incorporation of fluorine, can significantly enhance metabolic stability, binding affinity, and bioavailability of drug candidates. Consequently, reliable and reproducible synthetic access to a diverse range of these building blocks is of paramount importance to researchers in both academic and industrial settings. This guide provides a comparative analysis of common synthetic strategies for preparing substituted fluoroanilines, with a focus on reproducibility, scalability, and potential challenges. Experimental data and detailed protocols are provided to inform synthetic planning and optimization.

## Key Synthetic Strategies: A Comparative Overview

The synthesis of substituted fluoroanilines can be broadly categorized into three main approaches: 1) reduction of the corresponding fluoronitroarenes, 2) nucleophilic aromatic substitution (SNAr), and 3) modern cross-coupling methodologies. The choice of a particular

route is often dictated by factors such as the availability and cost of starting materials, the desired substitution pattern, and the scale of the reaction.

## Reduction of Fluoronitroarenes: The Workhorse Method

The reduction of a nitro group to an amine is a fundamental transformation in organic synthesis and remains one of the most common and reliable methods for preparing fluoroanilines.<sup>[1][2]</sup> This approach is particularly attractive due to the commercial availability of a wide variety of fluoronitrobenzene precursors.

Common Reducing Agents and Their Reproducibility:

- **Catalytic Hydrogenation** (e.g., H<sub>2</sub>/Pd/C, H<sub>2</sub>/Pt/C): This is often the cleanest and most efficient method, typically providing high yields and purity.<sup>[1][3]</sup> It is highly reproducible and scalable, making it a preferred choice for industrial applications.<sup>[1]</sup> However, a significant and often encountered challenge is hydrodehalogenation, where the fluorine or other halogen substituents are reductively cleaved.<sup>[4]</sup> Careful selection of the catalyst (e.g., platinum-based catalysts are sometimes less prone to dehalogenation than palladium) and optimization of reaction conditions (temperature, pressure, and solvent) are crucial to minimize this side reaction.<sup>[3][4]</sup>
- **Metal/Acid Reduction** (e.g., Fe/HCl, SnCl<sub>2</sub>/HCl): This classical method is cost-effective and robust. However, it generates significant amounts of metal waste, posing environmental concerns and requiring extensive workup procedures.<sup>[3]</sup> Reproducibility can be affected by the quality and activation of the metal.
- **Transfer Hydrogenation** (e.g., Hydrazine, Ammonium Formate): This method offers a milder alternative to high-pressure hydrogenation and can sometimes suppress dehalogenation.<sup>[4]</sup>

Table 1: Comparison of Reduction Methods for the Synthesis of 4-Fluoroaniline

Reduction Method	Starting Material	Reagents	Typical Yield (%)	Key Advantages	Key Disadvantages
Catalytic Hydrogenation	4-Fluoronitrobenzene	H <sub>2</sub> , 10% Pd/C, Methanol	>95[1]	High yield, high purity, clean reaction.[1]	Potential for dehalogenation, requires specialized equipment.[4]
Iron Reduction	4-Fluoronitrobenzene	Fe, HCl, Ethanol/Water	~85-90[3]	Low-cost reagents.	Generates significant metal waste, strenuous workup.[3]

## Experimental Protocol: Catalytic Hydrogenation of 4-Fluoronitrobenzene[1]

Materials:

- 4-Fluoronitrobenzene
- Methanol (MeOH)
- 10% Palladium on Carbon (10% Pd/C)
- Hydrogen gas (H<sub>2</sub>)
- Inert gas (Nitrogen or Argon)
- Dichloromethane (DCM)
- Filtration agent (e.g., Celite®)

Procedure:

- In a suitable hydrogenation vessel, dissolve 4-fluoronitrobenzene (1.0 eq) in methanol (10-20 mL per gram of substrate).
- Carefully add 10% Pd/C (1-5 mol%) to the solution under an inert atmosphere.
- Seal the vessel and purge with hydrogen gas.
- Stir the reaction mixture vigorously under a positive pressure of hydrogen (typically 1-4 atm) at room temperature.
- Monitor the reaction progress by Thin Layer Chromatography (TLC) or Gas Chromatography (GC).
- Upon completion, purge the vessel with an inert gas.
- Filter the reaction mixture through a pad of Celite® to remove the catalyst, washing the pad with methanol or DCM.
- Combine the filtrate and washings and concentrate under reduced pressure to yield the crude 4-fluoroaniline.
- Further purification can be achieved by distillation if necessary.

## Nucleophilic Aromatic Substitution (SNAr): A Versatile Approach

SNAr reactions provide a powerful means to introduce the aniline moiety, especially when the fluoroarene is activated by electron-withdrawing groups (EWGs) positioned ortho or para to the fluorine atom.<sup>[5][6]</sup> The high electronegativity of fluorine makes it a good leaving group in these reactions.<sup>[6]</sup>

Factors Influencing Reproducibility:

- **Substrate Activation:** The presence of strong EWGs (e.g., -NO<sub>2</sub>, -CN, -C(O)R) is crucial for the reaction to proceed efficiently.<sup>[5]</sup> Without sufficient activation, harsh reaction conditions are often required, which can lead to side reactions and reduced reproducibility.<sup>[7]</sup>

- Nucleophile and Base: The choice of the amine nucleophile and the base is critical. Stronger bases can lead to side reactions, while weaker bases may result in incomplete conversion.
- Solvent: Polar aprotic solvents like DMF, DMSO, or NMP are typically used to facilitate the reaction.[8] The purity of the solvent is important for consistent results.

A mild, transition-metal-free amination of fluoroarenes catalyzed by fluoride ions has been reported, offering an alternative to traditional S<sub>N</sub>Ar conditions.[5][9] This method utilizes trimethylsilyl-protected amines, which react with electron-deficient fluoroarenes in the presence of a fluoride source like CsF.[5]

## Experimental Protocol: Fluoride-Ion Catalyzed Amination of a Fluoroarene[5]

Materials:

- Electron-deficient fluoroarene
- Trimethylsilylated amine (e.g., trimethylsilylimidazole)
- Cesium Fluoride (CsF)
- Anhydrous Dimethylformamide (DMF)

Procedure:

- To an oven-dried reaction vessel under an inert atmosphere, add the fluoroarene (1.0 eq), trimethylsilylated amine (1.05 eq), and CsF (0.24 eq).
- Add anhydrous DMF and stir the mixture at 60 °C.
- Monitor the reaction by GC or TLC.
- Upon completion, cool the reaction to room temperature and perform an appropriate aqueous workup.
- Extract the product with a suitable organic solvent, dry the organic layer, and concentrate under reduced pressure.

- Purify the crude product by column chromatography.

## Modern Cross-Coupling Methods: Expanding the Scope

Palladium-catalyzed Buchwald-Hartwig amination and copper-catalyzed Ullmann condensation have emerged as powerful and versatile methods for the synthesis of aryl amines, including substituted fluoroanilines.<sup>[10][11][12][13]</sup> These reactions have significantly expanded the scope of accessible fluoroaniline derivatives, allowing for the coupling of a wide range of aryl halides and amines under relatively mild conditions.

### Buchwald-Hartwig Amination:

This palladium-catalyzed reaction is highly versatile and tolerates a broad range of functional groups.<sup>[10][12]</sup> The reproducibility of the Buchwald-Hartwig amination is highly dependent on the choice of palladium precursor, phosphine ligand, base, and solvent.<sup>[10][14]</sup> Sterically hindered and electron-rich phosphine ligands have been developed to improve reaction efficiency and scope.<sup>[12]</sup>

### Ullmann Condensation:

The copper-catalyzed Ullmann condensation is a classical method that has seen a resurgence with the development of improved catalyst systems.<sup>[11][13]</sup> While traditional Ullmann reactions often require harsh conditions, modern protocols utilize ligands such as diamines to facilitate the reaction at lower temperatures.<sup>[15]</sup>

### Table 2: Comparison of Cross-Coupling Methods

Method	Catalyst System	Substrates	Key Advantages	Key Disadvantages
Buchwald-Hartwig Amination	Palladium precatalyst + Phosphine ligand	Aryl halides/triflates + Amines	Broad substrate scope, high functional group tolerance, mild conditions.[12]	Catalyst cost, sensitivity to air and moisture.
Ullmann Condensation	Copper catalyst (often with a ligand)	Aryl halides + Amines	Lower catalyst cost compared to palladium.	Often requires higher temperatures than Buchwald-Hartwig.[13]

## Experimental Protocol: Palladium-Catalyzed Buchwald-Hartwig Amination[10]

Materials:

- Aryl halide (e.g., 4-bromofluorobenzene)
- Amine source (e.g., benzophenone imine or an ammonia equivalent)
- Palladium precatalyst (e.g., Pd<sub>2</sub>(dba)<sub>3</sub>)
- Phosphine ligand (e.g., Xantphos)
- Strong base (e.g., Sodium tert-butoxide)
- Anhydrous toluene

Procedure:

- To an oven-dried Schlenk tube under an inert atmosphere, add the aryl halide (1.0 eq), palladium precatalyst (e.g., 2 mol%), phosphine ligand (e.g., 4 mol%), and base (e.g., 1.4 eq).

- Add the amine source (1.2 eq) and anhydrous, degassed toluene.
- Seal the tube and heat the reaction mixture with stirring (e.g., 80-110 °C).
- Monitor the reaction by TLC or GC-MS.
- Upon completion, cool the reaction to room temperature, dilute with a suitable organic solvent, and wash with water and brine.
- Dry the organic layer, filter, and concentrate under reduced pressure.
- Purify the crude product by column chromatography.

## Visualization of Synthetic Workflows

To better illustrate the relationships between the different synthetic strategies, the following diagrams are provided.

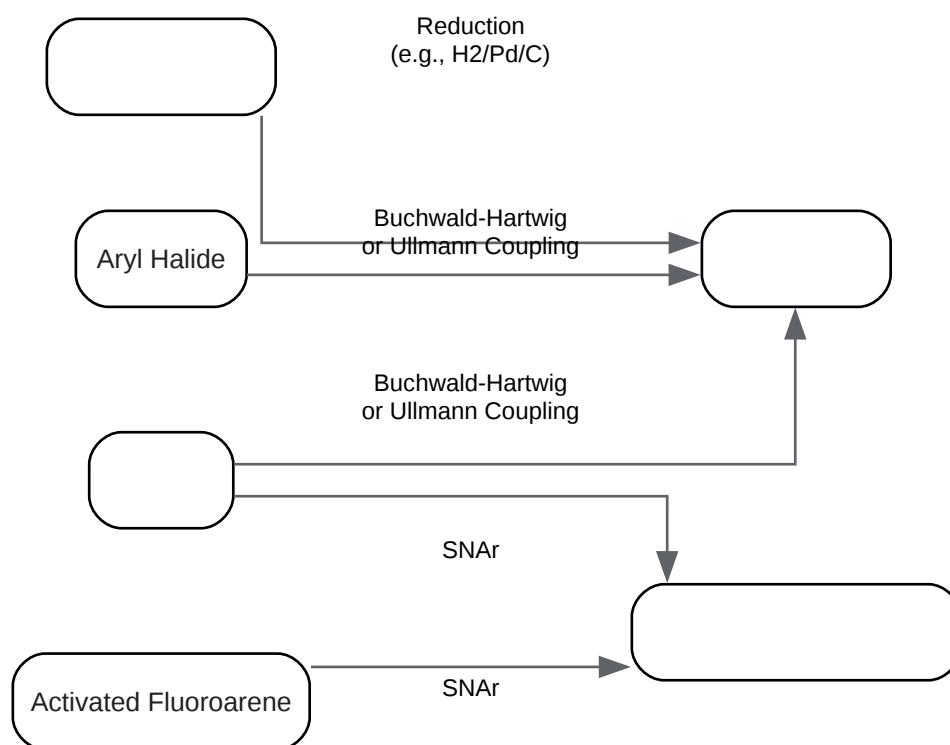

[Click to download full resolution via product page](#)

Caption: Key synthetic pathways to substituted fluoroanilines.

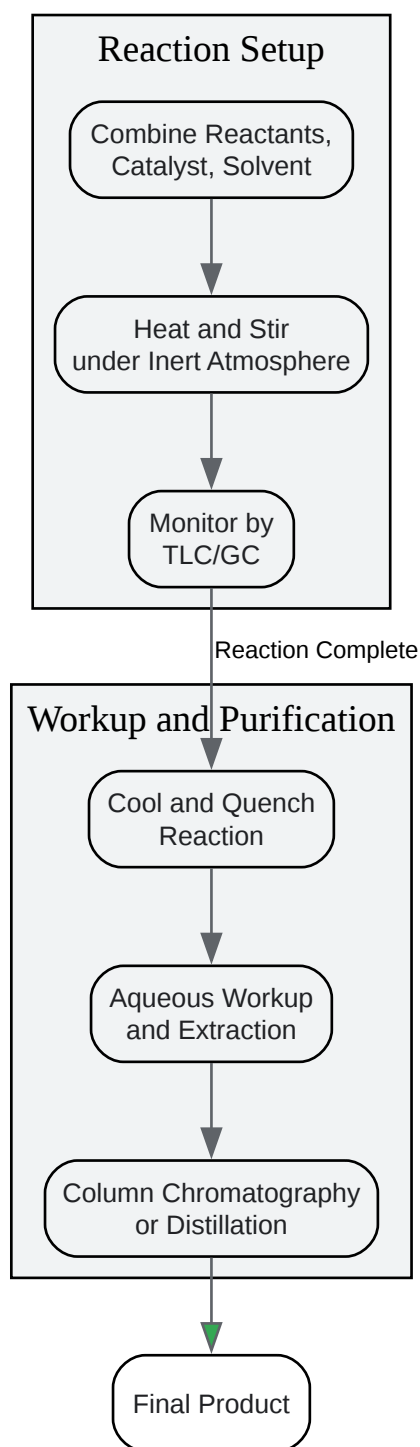

[Click to download full resolution via product page](#)

Caption: A general experimental workflow for the synthesis of substituted fluoroanilines.

## Conclusion and Future Directions

The reproducible synthesis of substituted fluoroanilines is a critical endeavor for advancing drug discovery and development. While the reduction of fluoronitroarenes remains a highly reliable and scalable method, challenges such as dehalogenation require careful process optimization. Nucleophilic aromatic substitution offers a versatile route for specific substitution patterns, particularly with the advent of milder, catalyzed approaches. Modern cross-coupling reactions, especially the Buchwald-Hartwig amination, have revolutionized the field by providing unparalleled scope and functional group tolerance.

Future research will likely focus on the development of even more robust and sustainable catalytic systems, including those that utilize earth-abundant metals or photocatalysis.[7] The continued exploration of orthogonal protection group strategies will also be crucial for the efficient synthesis of complex, polyfunctionalized fluoroanilines.[16] By understanding the nuances and reproducibility of each synthetic protocol, researchers can make more informed decisions to accelerate their research and development efforts.

## References

- Dehe, D., Munstein, I., Reis, A., & Thiel, W. R. (2011). Mild transition-metal-free amination of fluoroarenes catalyzed by fluoride ions. *The Journal of Organic Chemistry*, 76(4), 1151–1154. [[Link](#)]
- Dehe, D., Munstein, I., Reis, A., & Thiel, W. R. (2011). Mild Transition-Metal-Free Amination of Fluoroarenes Catalyzed by Fluoride Ions. *The Journal of Organic Chemistry*, 76(4), 1151-1154. [[Link](#)]
- Li, W., et al. (2018). Silver-catalyzed intermolecular amination of fluoroarenes. *Organic & Biomolecular Chemistry*, 16(33), 6045-6049. [[Link](#)]
- Li, W., et al. (2018). Silver-catalyzed intermolecular amination of fluoroarenes. *Organic & Biomolecular Chemistry*, 16(33), 6045-6049. [[Link](#)]
- Chemistry Letters. (1996). *Chemistry Letters*, 25(1), 1-84. [[Link](#)]
- Majek, M., et al. (2023). Consecutive Multiphoton-Mediated Defluorinative Amination of Fluoroarenes. *Journal of the American Chemical Society*. [[Link](#)]

- NINGBO INNO PHARMCHEM CO.,LTD. (n.d.). Mastering Organic Synthesis with 2-Chloro-3-fluoroaniline: A Chemical Building Block Deep Dive. NINGBO INNO PHARMCHEM CO.,LTD.[\[Link\]](#)
- ResearchGate. (2023). Optimization of the synthesis process for 3-chloro-4-fluoroaniline. ResearchGate. [\[Link\]](#)
- FAQ. (2020). How to Prepare 2-Fluoroaniline through Hydrogenation of Ortho-Fluoronitrobenzene?. FAQ. [\[Link\]](#)
- Ritter, T., et al. (2014). Synthesis and Late-Stage Functionalization of Complex Molecules through C–H Fluorination and Nucleophilic Aromatic Substitution. *Journal of the American Chemical Society*, 136(28), 9998-10009. [\[Link\]](#)
- Osmialowski, B., et al. (2001). 4-Fluoroanilines: synthesis and decomposition. *Journal of Fluorine Chemistry*, 110(1), 87-96. [\[Link\]](#)
- University of Bristol. (n.d.). VI Protecting Groups and Orthogonal Protection Strategies. University of Bristol. [\[Link\]](#)
- Zhang, W., et al. (2006). Palladium-Catalyzed Buchwald–Hartwig Type Amination of Fluorous Arylsulfonates. *Tetrahedron Letters*, 47(10), 1777-1780. [\[Link\]](#)
- Wikipedia. (n.d.). Buchwald–Hartwig amination. Wikipedia. [\[Link\]](#)
- ACS Publications. (2022). Protecting Group Strategies for Complex Molecule Synthesis in Medicinal Chemistry. *ACS Medicinal Chemistry Letters*. [\[Link\]](#)
- Wikipedia. (n.d.). Ullmann condensation. Wikipedia. [\[Link\]](#)
- ResearchGate. (2021). Synthesis of Fluorinated Acridines via Sequential Micellar Buchwald–Hartwig Amination/Cyclization of Aryl Bromides. ResearchGate. [\[Link\]](#)
- ResearchGate. (2020). Synthetic route for 3-fluoro-4-morpholinoaniline, and its sulfonamides and carbamates. ResearchGate. [\[Link\]](#)

- ResearchGate. (2001). Synthesis and characterization of fluorine-substituted polyanilines. ResearchGate. [\[Link\]](#)
- Beier, P., et al. (2016). Synthesis and nucleophilic aromatic substitution of 3-fluoro-5-nitro-1-(pentafluorosulfanyl)benzene. Beilstein Journal of Organic Chemistry, 12, 253-259. [\[Link\]](#)
- Pharmaceutical Technology. (2015). Overcoming Challenges in Fluorine-Based Chemistry. Pharmaceutical Technology. [\[Link\]](#)
- Organic Synthesis. (n.d.). Buchwald-Hartwig Coupling. Organic Synthesis. [\[Link\]](#)
- Google Patents. (n.d.). CN102173995A - Synthesis method of m-fluoroaniline.
- Google Patents. (n.d.). US4145364A - Preparation of fluorinated anilines.
- MDPI. (2006). A Simple Synthetic Route to Methyl 3-Fluoropyridine-4-carboxylate by Nucleophilic Aromatic Substitution. Molecules, 11(2), 124-129. [\[Link\]](#)
- Thieme. (n.d.). 2 Protection of Functional Groups. Thieme. [\[Link\]](#)
- Alcaide, B., et al. (2023). Difluoroalkylation of Anilines via Photoinduced Methods. Molecules, 28(16), 6101. [\[Link\]](#)
- PubMed. (2001). Synthesis and characterization of fluoro-substituted polyaniline. PubMed. [\[Link\]](#)
- WikiDoc. (2012). Ullmann condensation. WikiDoc. [\[Link\]](#)
- Organic Synthesis. (n.d.). Ullmann Coupling & other Cu Catalyzed reactions. Organic Synthesis. [\[Link\]](#)
- PubMed. (2024). Orthogonal Deprotection Strategy of Fmoc Provides Improved Synthesis of Sensitive Peptides: Application to Z-Arg-Lys-AOMK. PubMed. [\[Link\]](#)
- National Center for Biotechnology Information. (2023). Special issue: reproducibility in synthetic biology. Synthetic Biology, 8(1), ysad025. [\[Link\]](#)

**Need Custom Synthesis?**

BenchChem offers custom synthesis for rare earth carbides and specific isotopic labeling.

Email: [info@benchchem.com](mailto:info@benchchem.com) or [Request Quote Online](#).

## Sources

- 1. [pdf.benchchem.com](https://pdf.benchchem.com) [[pdf.benchchem.com](https://pdf.benchchem.com)]
- 2. [benchchem.com](https://benchchem.com) [[benchchem.com](https://benchchem.com)]
- 3. [pdf.benchchem.com](https://pdf.benchchem.com) [[pdf.benchchem.com](https://pdf.benchchem.com)]
- 4. [pdf.benchchem.com](https://pdf.benchchem.com) [[pdf.benchchem.com](https://pdf.benchchem.com)]
- 5. [pubs.acs.org](https://pubs.acs.org) [[pubs.acs.org](https://pubs.acs.org)]
- 6. Synthesis and Late-Stage Functionalization of Complex Molecules through C–H Fluorination and Nucleophilic Aromatic Substitution - PMC [[pubmed.ncbi.nlm.nih.gov](https://pubmed.ncbi.nlm.nih.gov)]
- 7. Consecutive Multiphoton-Mediated Defluorinative Amination of Fluoroarenes - PubMed [[pubmed.ncbi.nlm.nih.gov](https://pubmed.ncbi.nlm.nih.gov)]
- 8. Synthesis and nucleophilic aromatic substitution of 3-fluoro-5-nitro-1-(pentafluorosulfanyl)benzene - PMC [[pubmed.ncbi.nlm.nih.gov](https://pubmed.ncbi.nlm.nih.gov)]
- 9. Mild transition-metal-free amination of fluoroarenes catalyzed by fluoride ions - PubMed [[pubmed.ncbi.nlm.nih.gov](https://pubmed.ncbi.nlm.nih.gov)]
- 10. [pdf.benchchem.com](https://pdf.benchchem.com) [[pdf.benchchem.com](https://pdf.benchchem.com)]
- 11. [pdf.benchchem.com](https://pdf.benchchem.com) [[pdf.benchchem.com](https://pdf.benchchem.com)]
- 12. Buchwald–Hartwig amination - Wikipedia [[en.wikipedia.org](https://en.wikipedia.org)]
- 13. Ullmann condensation - Wikipedia [[en.wikipedia.org](https://en.wikipedia.org)]
- 14. [organic-synthesis.com](https://organic-synthesis.com) [[organic-synthesis.com](https://organic-synthesis.com)]
- 15. [organic-synthesis.com](https://organic-synthesis.com) [[organic-synthesis.com](https://organic-synthesis.com)]
- 16. [chemweb.bham.ac.uk](https://chemweb.bham.ac.uk) [[chemweb.bham.ac.uk](https://chemweb.bham.ac.uk)]
- To cite this document: BenchChem. [A Researcher's Guide to the Reproducible Synthesis of Substituted Fluoroanilines]. BenchChem, [2026]. [Online PDF]. Available at: [<https://www.benchchem.com/product/b3173238/docs#a-researcher-s-guide-to-the-reproducible-synthesis-of-substituted-fluoroanilines>]

**Disclaimer & Data Validity:**

The information provided in this document is for Research Use Only (RUO) and is strictly not intended for diagnostic or therapeutic procedures. While BenchChem strives to provide accurate protocols, we make no warranties, express or implied, regarding the fitness of this product for every specific experimental setup.

**Technical Support:** The protocols provided are for reference purposes. Unsure if this reagent suits your experiment?

**Need Industrial/Bulk Grade?** [Request Custom Synthesis Quote](#)

## BenchChem

Our mission is to be the trusted global source of essential and advanced chemicals, empowering scientists and researchers to drive progress in science and industry.

### Contact

Address: 3281 E Guasti Rd  
Ontario, CA 91761, United States  
Phone: (601) 213-4426  
Email: [info@benchchem.com](mailto:info@benchchem.com)

[Contact our Ph.D. Support Team for a compatibility check](#)