

Definitive Guide: Mass Spectrometry Fragmentation of 5-Bromo-2-(2- propoxyethoxy)aniline

Author: BenchChem Technical Support Team. **Date:** April 2026

Compound of Interest

Compound Name:	5-Bromo-2-(2-propoxyethoxy)aniline
CAS No.:	946743-34-6
Cat. No.:	B3172907

[Get Quote](#)

Executive Summary & Application Scope

Product Identity: **5-Bromo-2-(2-propoxyethoxy)aniline** (CAS: 946743-34-6) Molecular Formula: $C_{11}H_{16}BrNO_2$ Exact Mass: 273.0364 (for ^{79}Br) / 275.0344 (for ^{81}Br)

This guide provides a technical analysis of the mass spectrometry (MS) behavior of **5-Bromo-2-(2-propoxyethoxy)aniline**, a critical intermediate scaffold often employed in the synthesis of tyrosine kinase inhibitors (TKIs). Accurate characterization of this pharmacophore is essential for distinguishing it from potential process impurities (e.g., hydrolysis products like 2-amino-4-bromophenol) and structural analogs.

We compare the fragmentation "performance"—defined here as structural elucidation capability and sensitivity—across two primary ionization modalities: Electrospray Ionization (ESI-QTOF) and Electron Ionization (EI-GCMS).

Experimental Protocols (Self-Validating Systems)

To ensure reproducibility, the following protocols utilize internal validation steps (isotopic abundance checks) to confirm system performance before data acquisition.

Protocol A: High-Resolution ESI-MS/MS (LC-QTOF)

Best for: Impurity profiling in polar solvents, metabolic stability studies.

- Sample Preparation: Dissolve 1 mg of analyte in 1 mL Acetonitrile (ACN). Dilute to 1 µg/mL with 50:50 ACN:Water (+0.1% Formic Acid).
- System Setup:
 - Source: ESI Positive Mode (+).
 - Capillary Voltage: 3.5 kV.
 - Collision Energy (CE): Ramp 10–40 eV.
- Validation Check (Pass/Fail):
 - Observe the molecular ion cluster $[M+H]^+$ at m/z 274.04 and 276.04.
 - Criterion: The intensity ratio of m/z 274 to 276 must be 1:1 ($\pm 10\%$). If the ratio deviates (e.g., 3:1), the sample is contaminated with a non-brominated analog (chlorinated or des-bromo).

Protocol B: Electron Ionization (EI-GCMS)

Best for: Library matching, volatile impurity analysis.

- Sample Preparation: Dissolve 1 mg in 1 mL Dichloromethane (DCM).
- GC Parameters: DB-5MS column (30m x 0.25mm); Injector 250°C; Split 20:1.
- MS Source: 70 eV electron impact.
- Validation Check:

- Monitor the retention time (RT) relative to an internal standard (e.g., naphthalene-d8).
- Criterion: The molecular ion ($M^{+\bullet}$) must be visible at m/z 273/275. If $M^{+\bullet}$ is absent, lower the injector temperature to prevent thermal degradation of the ether chain.

Comparative Analysis: Fragmentation Pathways

The Isotopic Signature (The "Anchor")

Before analyzing fragmentation, the Bromine Isotope Pattern serves as the primary anchor. Unlike standard organic molecules, this compound will always present a "twin peak" signature separated by 2 Da in a 1:1 intensity ratio (^{79}Br and ^{81}Br).

- Implication: Every fragment ion retaining the bromine atom must display this doublet. A fragment appearing as a singlet indicates the loss of the bromine (rare in soft ionization) or a contaminant.

ESI-MS/MS Fragmentation (Soft Ionization)

In ESI(+), the protonated molecule $[M+H]^+$ is the precursor. The fragmentation is driven by the ether chain stability and the basicity of the aniline nitrogen.

- Pathway A (Ether Cleavage): The most facile cleavage occurs at the ether linkage.
 - Precursor: m/z 274/276.
 - Primary Fragment: Loss of the propoxyethyl chain ($\text{C}_5\text{H}_{11}\text{O}^\bullet$ or neutral loss of alcohol) is less common in ESI than the inductive cleavage of the alkyl tail.
 - Dominant Fragment: Loss of the propyl group ($-\text{C}_3\text{H}_7$) or the propoxy group ($-\text{OC}_3\text{H}_7$).
 - Diagnostic Ion: m/z 188/190 (2-amino-4-bromophenol core). This confirms the integrity of the aromatic ring and the bromine position.

EI-MS Fragmentation (Hard Ionization)

EI imparts 70 eV, causing extensive fragmentation useful for fingerprinting.

- Alpha-Cleavage: The ether oxygen stabilizes the radical cation, promoting cleavage of the C–C bond next to the oxygen.
- McLafferty Rearrangement: The propyl chain allows for a six-membered transition state, facilitating hydrogen transfer and alkene elimination (propene).

Visualization of Fragmentation Pathways

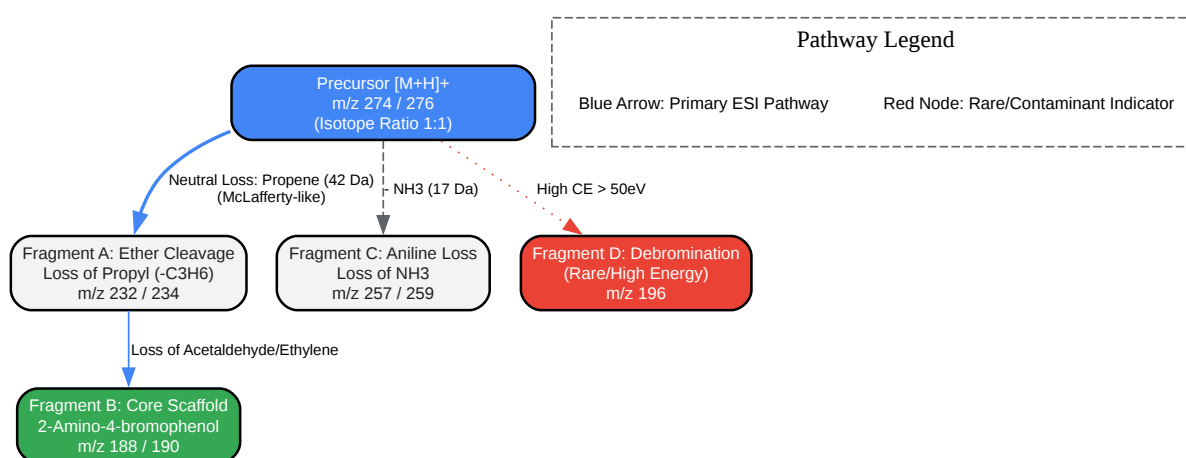

[Click to download full resolution via product page](#)

Figure 1: Predicted ESI(+) fragmentation pathway. The transition from m/z 274 to 188 is the primary diagnostic transition for confirmation.

Performance Comparison: ESI vs. EI vs. Analogs

This section compares the "performance" of the analyte's signal against potential interferences (Analogues) and detection methods.

Table 1: Diagnostic Ion Comparison (Differentiation Matrix)

Use this table to distinguish the target product from common synthesis impurities.

Compound / Analog	Molecular Ion (M+H) ⁺	Key Fragment 1 (Loss of Alkyl)	Key Fragment 2 (Core Phenol)	Differentiation Factor
Target: 5-Bromo-2-(2-propoxyethoxy)aniline	274 / 276	232 / 234 (-42 Da)	188 / 190	Base Peak 188/190
Analog A: 5-Bromo-2-(2-ethoxyethoxy)aniline	260 / 262	232 / 234 (-28 Da)	188 / 190	M+H Shift (-14 Da)
Analog B: 5-Bromo-2-methoxyaniline	202 / 204	187 / 189 (-15 Da)	N/A	No ether chain fragments
Impurity C: 2-Amino-4-bromophenol	188 / 190	N/A	160 / 162 (-CO)	Parent matches Target Fragment 2

Table 2: Method Performance Guide

Objective comparison of detection techniques.

Feature	ESI-QTOF (Recommended)	EI-GCMS (Alternative)
Sensitivity	High (pg/mL range) due to basic amine protonation.	Moderate (ng/mL range).
Structural Info	Excellent for confirming MW and ether chain length via MS/MS.	Excellent for library matching (NIST) and "fingerprinting".
Risk Factor	Adduct formation ($[M+Na]^+$) can complicate spectra if salts are present.	Thermal degradation of the ether chain in the injector port.
Quantification	Linear dynamic range is superior for biological matrices.	Better for residual solvent/volatile impurity analysis.

Decision Framework for Researchers

When developing a release assay or pharmacokinetic study, use the following logic flow to select the appropriate MS methodology.

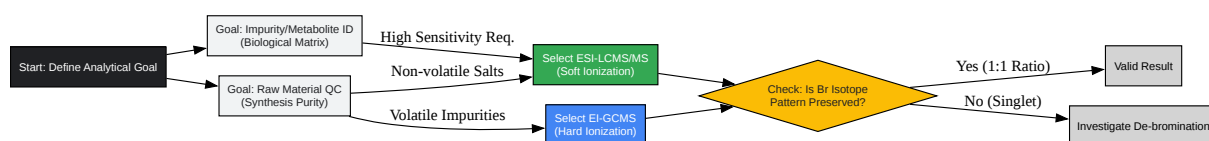

[Click to download full resolution via product page](#)

Figure 2: Decision tree for selecting the optimal mass spectrometry method based on research stage.

References

- National Center for Biotechnology Information (2025). PubChem Compound Summary for CID 793016, 2-Bromo-5-methoxyaniline (Analog Reference). Retrieved from [\[Link\]](#)

- McLafferty, F. W., & Tureček, F. (1993). Interpretation of Mass Spectra. University Science Books. (Standard text for McLafferty rearrangement mechanisms cited in Section 3.3).
- To cite this document: BenchChem. [Definitive Guide: Mass Spectrometry Fragmentation of 5-Bromo-2-(2-propoxyethoxy)aniline]. BenchChem, [2026]. [Online PDF]. Available at: [<https://www.benchchem.com/product/b3172907/docs#definitive-guide-mass-spectrometry-fragmentation-of-5-bromo-2-2-propoxyethoxy-aniline>]

Disclaimer & Data Validity:

The information provided in this document is for Research Use Only (RUO) and is strictly not intended for diagnostic or therapeutic procedures. While BenchChem strives to provide accurate protocols, we make no warranties, express or implied, regarding the fitness of this product for every specific experimental setup.

Technical Support: The protocols provided are for reference purposes. Unsure if this reagent suits your experiment?

Need Industrial/Bulk Grade? [Request Custom Synthesis Quote](#)

BenchChem

Our mission is to be the trusted global source of essential and advanced chemicals, empowering scientists and researchers to drive progress in science and industry.

Contact

Address: 3281 E Guasti Rd
Ontario, CA 91761, United States
Phone: (601) 213-4426
Email: info@benchchem.com

[Contact our Ph.D. Support Team for a compatibility check](#)

