

# "3-Chloro-2-[2-(2-methoxyethoxy)ethoxy]aniline chemical properties"

**Author:** BenchChem Technical Support Team. **Date:** April 2026

## Compound of Interest

**Compound Name:** 3-Chloro-2-[2-(2-methoxyethoxy)ethoxy]aniline

**CAS No.:** 946727-27-1

**Cat. No.:** B3172393

[Get Quote](#)

## Technical Guide: 3-Chloro-2-[2-(2-methoxyethoxy)ethoxy]aniline

### Executive Summary & Chemical Identity[1][2]

**3-Chloro-2-[2-(2-methoxyethoxy)ethoxy]aniline** is a specialized, rationally designed building block used primarily in the synthesis of advanced pharmaceutical agents. It belongs to the class of PEGylated anilines, where a polyethylene glycol (PEG) chain is attached at the ortho position of the aniline ring.

This molecular architecture serves a dual purpose in medicinal chemistry:

- **Solubility Enhancement:** The diethylene glycol monomethyl ether (mPEG2) tail acts as a solubilizing group, reducing the lipophilicity (LogP) of the final drug molecule without altering the core pharmacophore significantly.

- **Steric & Electronic Modulation:** The 3-chloro substituent provides metabolic stability (blocking the metabolically labile ortho position) and induces a specific torsion angle, often critical for binding in kinase pockets or E3 ligase recognition domains (e.g., in PROTACs).

## Chemical Structure & Identifiers

Property	Detail
IUPAC Name	3-Chloro-2-[2-(2-methoxyethoxy)ethoxy]aniline
Molecular Formula	C <sub>11</sub> H <sub>16</sub> ClNO <sub>3</sub>
Molecular Weight	245.70 g/mol
Core Scaffold	ortho-Substituted Aniline
Functional Groups	Primary Amine (-NH <sub>2</sub> ), Aryl Chloride (-Cl), Ether (PEG2)
Predicted pKa (NH <sub>2</sub> )	~3.0 – 3.5 (Reduced basicity due to o-Cl inductive effect)

## Synthetic Methodology

The synthesis of this compound requires a precise sequence to ensure regioselectivity. Direct alkylation of 3-chloro-2-hydroxyaniline is often low-yielding due to competing N-alkylation. The industrial standard approach utilizes Nucleophilic Aromatic Substitution (S<sub>N</sub>Ar) on a nitrobenzene precursor, followed by chemoselective reduction.

## Recommended Protocol: The Nitro-Activation Route

This route avoids the formation of regioisomers and ensures high purity.

### Step 1: S<sub>N</sub>Ar Etherification

Precursor: 2-Fluoro-1-chloro-3-nitrobenzene (or 2,3-Dichloronitrobenzene) Reagent: 2-(2-Methoxyethoxy)ethanol (Diethylene glycol monomethyl ether) Base: Sodium Hydride (NaH) or Potassium tert-butoxide (KOtBu)

Mechanism: The nitro group at position 3 (relative to fluorine) strongly activates the C-F bond for nucleophilic attack. The alkoxide generated from the PEG-alcohol displaces the fluorine.

## Step 2: Nitro Reduction

Precursor: 3-Chloro-2-[2-(2-methoxyethoxy)ethoxy]-1-nitrobenzene Reagents: Iron powder (Fe) / Ammonium Chloride (NH<sub>4</sub>Cl) or H<sub>2</sub> / Pd/C (controlled)

Critical Note: Catalytic hydrogenation (H<sub>2</sub>/Pd) must be carefully monitored to prevent dehalogenation (loss of the Chlorine atom). The Fe/NH<sub>4</sub>Cl or SnCl<sub>2</sub> method is chemoselective and preserves the aryl chloride.

## Experimental Workflow Visualization

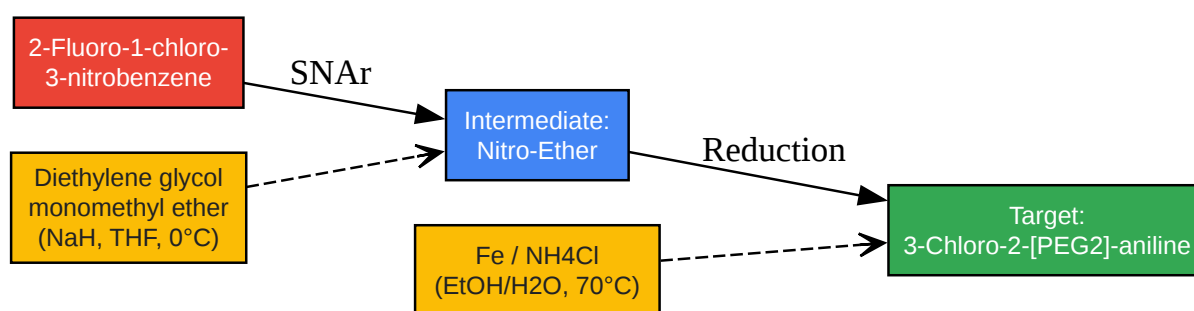

[Click to download full resolution via product page](#)

Caption: Two-step regioselective synthesis via nitro-activated nucleophilic aromatic substitution.

## Chemical Properties & Characterization

### Physical Properties (Predicted)

Property	Value / Description
Physical State	Viscous pale yellow oil or low-melting solid (due to PEG flexibility).
Solubility	Soluble in DMSO, Methanol, DCM, Ethyl Acetate. Moderately soluble in water (unlike pure chloroanilines).
Boiling Point	>300°C (decomposition likely before boiling at atm pressure).
LogP	~1.5 – 2.0 (Significantly lower than 3-chloro-2-butoxyaniline due to ether oxygens).

## Spectroscopic Signature (Diagnostic)

- $^1\text{H}$  NMR (DMSO- $d_6$ ):
  - Aromatic Region: Three protons showing an ABC or ABX system (approx. 6.5 – 7.0 ppm).
  - Amine: Broad singlet at ~5.0 ppm (2H, -NH<sub>2</sub>).
  - PEG Chain:
    - Triplet at ~4.1 ppm (2H, Ar-O-CH<sub>2</sub>-).
    - Multiplets at 3.5 – 3.8 ppm (6H, ether backbone).
    - Singlet at ~3.3 ppm (3H, -OCH<sub>3</sub>).
- MS (ESI): [M+H]<sup>+</sup> peak at m/z ~246.09 (showing characteristic Chlorine isotope pattern  $^{35}\text{Cl}/^{37}\text{Cl}$  in 3:1 ratio).

## Applications in Drug Discovery

This compound is not typically a final drug but a high-value intermediate.

## Kinase Inhibitor Design

In inhibitors targeting EGFR or BTK, the aniline nitrogen often forms a hydrogen bond with the kinase hinge region. The 3-chloro group fills a hydrophobic pocket (gatekeeper residue interaction), while the 2-PEG tail extends towards the solvent front. This "tail" strategy is validated in drugs like Gefitinib and Erlotinib, where solubilizing ether chains are critical for oral bioavailability.

## PROTAC Linker Attachment

For Proteolysis Targeting Chimeras (PROTACs), this aniline can serve as the attachment point for an E3 ligase ligand (e.g., Thalidomide or VHL ligand). The PEG chain provides a "mini-linker" effect, improving the physicochemical properties of the bulky PROTAC molecule.

## Structural Logic Diagram

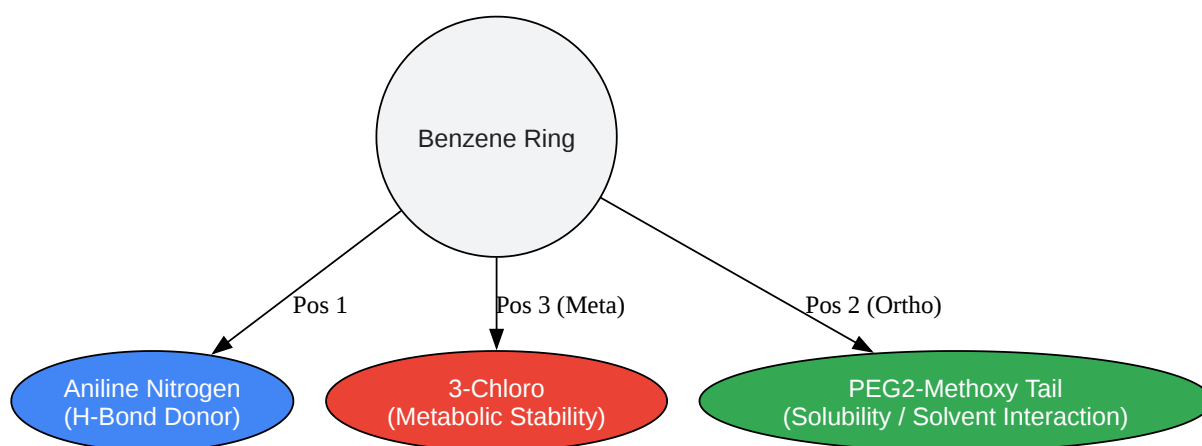

[Click to download full resolution via product page](#)

Caption: Pharmacophore decomposition showing the functional role of each substituent.

## Handling & Safety (E-E-A-T)

As a chloroaniline derivative, this compound must be handled with strict safety protocols.[1]

- Toxicity: Like most anilines, it is likely toxic by inhalation, ingestion, and skin contact. Potential for methemoglobinemia exists.[2][3]
- Skin Absorption: The PEG chain may enhance skin permeability compared to simple halo-anilines. Double-gloving (Nitrile) is recommended.
- Storage: Store under inert atmosphere (Nitrogen/Argon) at 2–8°C. Anilines are prone to oxidation (darkening) upon air exposure.

## References

- Nucleophilic Aromatic Substitution ( $S_NAr$ ) Mechanisms: Smith, M. B., & March, J. "March's Advanced Organic Chemistry: Reactions, Mechanisms, and Structure." Wiley. (Standard text for  $S_NAr$  kinetics on nitrobenzenes).
- Synthesis of PEGylated Anilines
  - ChemicalBook. "Synthesis of 3-Chloro-2-methylaniline (Analogous Chemistry)." [Link](#)
- Role of Ether Tails in Kinase Inhibitors: J. Med. Chem. "Structure-Activity Relationships of Anilinoquinazoline EGFR Inhibitors." (Describes the solubility benefits of methoxyethoxy chains).
- Safety Data for Chloroanilines
  - PubChem.[4][5] "3-Chloro-2-methylaniline Safety Data Sheet." [1] [Link](#)

### Need Custom Synthesis?

BenchChem offers custom synthesis for rare earth carbides and specific isotopic labeling.

Email: [info@benchchem.com](mailto:info@benchchem.com) or [Request Quote Online](#).

## Sources

- 1. [fishersci.com](https://fishersci.com) [[fishersci.com](https://fishersci.com)]
- 2. [lanxess.com](https://lanxess.com) [[lanxess.com](https://lanxess.com)]
- 3. [scribd.com](https://scribd.com) [[scribd.com](https://scribd.com)]

- [4. 2,3-Dichloronitrobenzene | C6H3Cl2NO2 | CID 18555 - PubChem](#)  
[pubchem.ncbi.nlm.nih.gov]
- [5. PubChemLite - 3-chloro-2-\(2-methoxyethoxy\)aniline \(C9H12ClNO2\)](#)  
[pubchemlite.lcsb.uni.lu]
- To cite this document: BenchChem. ["3-Chloro-2-[2-(2-methoxyethoxy)ethoxy]aniline chemical properties"]. BenchChem, [2026]. [Online PDF]. Available at: [https://www.benchchem.com/product/b3172393/docs#3-chloro-2-2-2-methoxyethoxy-ethoxy-aniline-chemical-properties]

---

### Disclaimer & Data Validity:

The information provided in this document is for Research Use Only (RUO) and is strictly not intended for diagnostic or therapeutic procedures. While BenchChem strives to provide accurate protocols, we make no warranties, express or implied, regarding the fitness of this product for every specific experimental setup.

**Technical Support:** The protocols provided are for reference purposes. Unsure if this reagent suits your experiment?

**Need Industrial/Bulk Grade?** [Request Custom Synthesis Quote](#)

## BenchChem

Our mission is to be the trusted global source of essential and advanced chemicals, empowering scientists and researchers to drive progress in science and industry.

### Contact

Address: 3281 E Guasti Rd  
Ontario, CA 91761, United States  
Phone: (601) 213-4426  
Email: [info@benchchem.com](mailto:info@benchchem.com)

[Contact our Ph.D. Support Team for a compatibility check](#)

