

Application Note: High-Fidelity Functionalization of 1-(2-methylbenzyl)-1H-pyrazol-4-amine

Author: BenchChem Technical Support Team. **Date:** April 2026

Compound of Interest

Compound Name: 1-[(2-Methylphenyl)methyl]-1H-pyrazol-4-amine

CAS No.: 898055-82-8

Cat. No.: B3165268

[Get Quote](#)

Executive Summary

This guide details the strategic deployment of 1-(2-methylbenzyl)-1H-pyrazol-4-amine (referred to herein as 1-MBA) as a nucleophilic building block.^[1] While 4-aminopyrazoles are privileged scaffolds in medicinal chemistry—ubiquitous in kinase inhibitors (e.g., JAK, CDK) and GPCR modulators—the specific 2-methylbenzyl substitution offers unique advantages. It provides increased metabolic stability against oxidative debenzylation compared to unsubstituted benzyl groups and introduces a defined steric vector that restricts bond rotation, often improving potency in hydrophobic pockets.

This document provides validated protocols for leveraging the 4-amino group in Amide Couplings, Buchwald-Hartwig Aminations, and Reductive Aminations, ensuring high yields and minimizing side reactions associated with the pyrazole core.

Chemical Profile & Handling

1-MBA behaves as a heteroaromatic amine (aniline-like) rather than an aliphatic amine.^[1] Its nucleophilicity is tempered by the aromatic pyrazole ring, requiring activated electrophiles or

catalysis for successful coupling.

Property	Description
Structure	Pyrazole ring substituted at N1 with 2-methylbenzyl; primary amine at C4.[1]
Nucleophilicity	Moderate. hybridized nitrogen character. Less reactive than benzylamine; comparable to 4-methoxyaniline.[1]
pKa (Conjugate Acid)	Estimated ~4.0–4.5. The free base is weak; protonation occurs at N2 (pyrazole nitrogen) before the exocyclic amine in strongly acidic media.
Solubility	High in DMSO, DMF, DCM, MeOH. Moderate in EtOAc.[2] Low in water/hexanes.
Stability	Stable to air and moisture. The N1-benzyl bond is robust but can be cleaved under high-pressure hydrogenolysis (though the 2-methyl group sterically hinders this cleavage compared to simple benzyls).[1]

Reaction Landscape & Decision Logic

The primary challenge in functionalizing 1-MBA is avoiding coordination of the pyridine-like nitrogen (N2) to metal catalysts or competing protonation.[1] The following diagram outlines the strategic pathways.

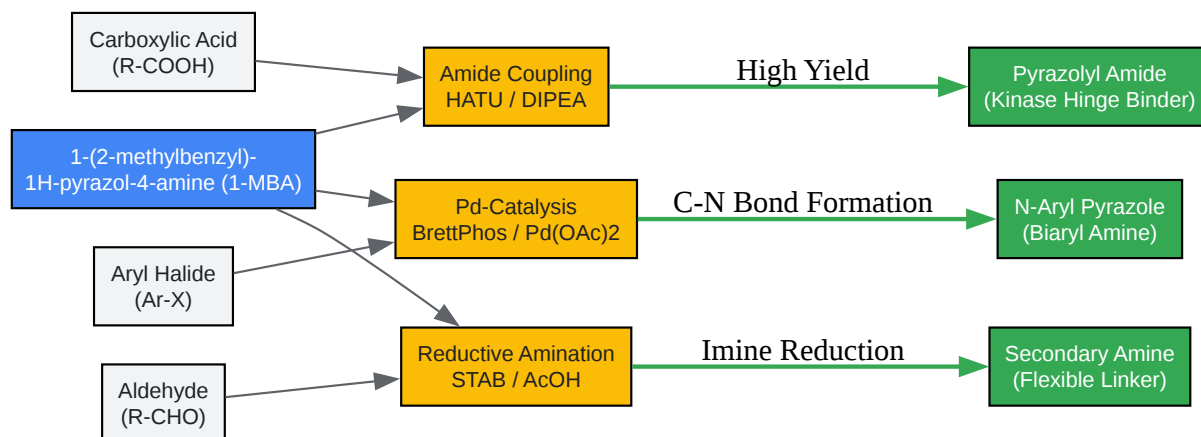

[Click to download full resolution via product page](#)

Figure 1: Strategic reaction pathways for 1-MBA functionalization.

Validated Protocols

Protocol A: High-Efficiency Amide Coupling

Application: Synthesis of kinase inhibitor libraries where the pyrazole amide acts as the hinge-binding motif.[1] Rationale: 1-MBA is less nucleophilic than alkyl amines.[1] Standard EDC/HOBt protocols often fail or proceed slowly. HATU is preferred for its rapid activation and high conversion rates with electron-poor anilines.[1]

Materials:

- 1-MBA (1.0 equiv)[1]
- Carboxylic Acid (1.1 equiv)
- HATU (1.2 equiv)
- DIPEA (N,N-Diisopropylethylamine) (3.0 equiv)[1]
- Solvent: Anhydrous DMF or DMAc[1]

Step-by-Step Procedure:

- Activation: In a dried vial, dissolve the Carboxylic Acid (1.0 mmol) in DMF (3 mL). Add DIPEA (3.0 mmol) followed by HATU (1.2 mmol). Stir at Room Temperature (RT) for 15 minutes.
 - Note: The solution should turn slightly yellow/orange upon activation.
- Addition: Add 1-MBA (1.0 mmol) directly to the activated ester solution.
- Reaction: Stir at 50°C for 4–16 hours.
 - Why heat? While some anilines react at RT, the steric bulk of the 2-methylbenzyl group and the electronics of the pyrazole often require mild heating to drive the reaction to completion.
- Workup:
 - Dilute with EtOAc (30 mL).
 - Wash with saturated NaHCO₃ (2 x 15 mL) to remove HATU byproducts.
 - Wash with water (2 x 15 mL) and brine (1 x 15 mL).
 - Dry over Na₂SO₄ and concentrate.[3]
- Purification: Flash chromatography (typically 0–10% MeOH in DCM).

Protocol B: Buchwald-Hartwig Cross-Coupling

Application: Installing aryl groups to form biaryl amines (e.g., mimicking the core of drugs like Pazopanib). Rationale: The pyrazole N₂ can poison Pd catalysts. Ligands like BrettPhos or XPhos are essential as they are bulky enough to prevent N₂ coordination and electron-rich enough to facilitate oxidative addition into deactivated aryl halides.[1]

Materials:

- 1-MBA (1.0 equiv)[1]
- Aryl Bromide/Iodide (1.0 equiv)
- Catalyst: Pd₂(dba)₃ (2 mol%) or Pd(OAc)₂

- Ligand: BrettPhos (4-6 mol%) (Preferred for primary amines)[1]
- Base: Cs₂CO₃ (2.0 equiv) or NaOtBu (1.4 equiv)
- Solvent: 1,4-Dioxane (degassed)[1][4]

Step-by-Step Procedure:

- Prep: Charge a microwave vial or Schlenk tube with 1-MBA, Aryl Halide, Base, Pd source, and Ligand.
- Inertion: Seal and purge with Argon/Nitrogen for 5 minutes.
- Solvation: Add degassed 1,4-Dioxane via syringe.
- Reaction: Heat to 100°C (oil bath) or 120°C (microwave) for 1–12 hours.
 - Monitoring: Check LCMS for consumption of the aryl halide.[5] If conversion stalls, add a second portion of catalyst/ligand.
- Workup: Filter through a Celite pad (eluting with EtOAc). Concentrate the filtrate.
- Purification: Reverse-phase HPLC is often recommended to remove trace phosphine oxides and Pd contaminants.[1]

Protocol C: Reductive Amination

Application: Creating flexible secondary amine linkers. Rationale: The intermediate imine formed between 1-MBA and an aldehyde is relatively stable but requires a stronger reducing agent than standard aliphatic amines due to conjugation.[1] Sodium Triacetoxyborohydride (STAB) is the reagent of choice.

Step-by-Step Procedure:

- Imine Formation: Dissolve 1-MBA (1.0 equiv) and Aldehyde (1.0 equiv) in DCE (1,2-Dichloroethane) or THF.[1]

- Acid Catalysis: Add Acetic Acid (1–2 drops, approx. 1.0 equiv) to catalyze imine formation. Stir for 1 hour at RT.
- Reduction: Add STAB (1.5–2.0 equiv) in one portion.
- Reaction: Stir at RT overnight.
- Quench: Quench with saturated aqueous NaHCO₃. Extract with DCM.[3]

Troubleshooting & Optimization Logic

Issue	Root Cause	Corrective Action
Low Conversion (Amide)	Poor nucleophilicity of 4-NH ₂ . [1]	Switch from HATU to Ghosez's Reagent (1-Chloro-N,N,2-trimethyl-1-propenylamine) to generate the acid chloride in situ.[1] Heat to 80°C.
Catalyst Poisoning (Pd)	Pyrazole N2 coordinating Pd.	Increase Ligand: Pd ratio to 2:1 or 3:[1]. Use tBuBrettPhos precatalyst (G3) for faster initiation.
Regioisomerism	Not applicable for 1-MBA.[1]	The N1 is fixed with the 2-methylbenzyl group.[1] Unlike unsubstituted pyrazoles, tautomerism is blocked, ensuring single-isomer products.[1]
Solubility Issues	Hydrophobicity of 2-methylbenzyl.	Use a co-solvent mixture of DCM/HFIP (Hexafluoroisopropanol) for difficult couplings. HFIP activates epoxides and stabilizes charged intermediates.

Workup & Purification Workflow

Efficient isolation is critical. The following flow ensures removal of toxic coupling reagents and metal residues.

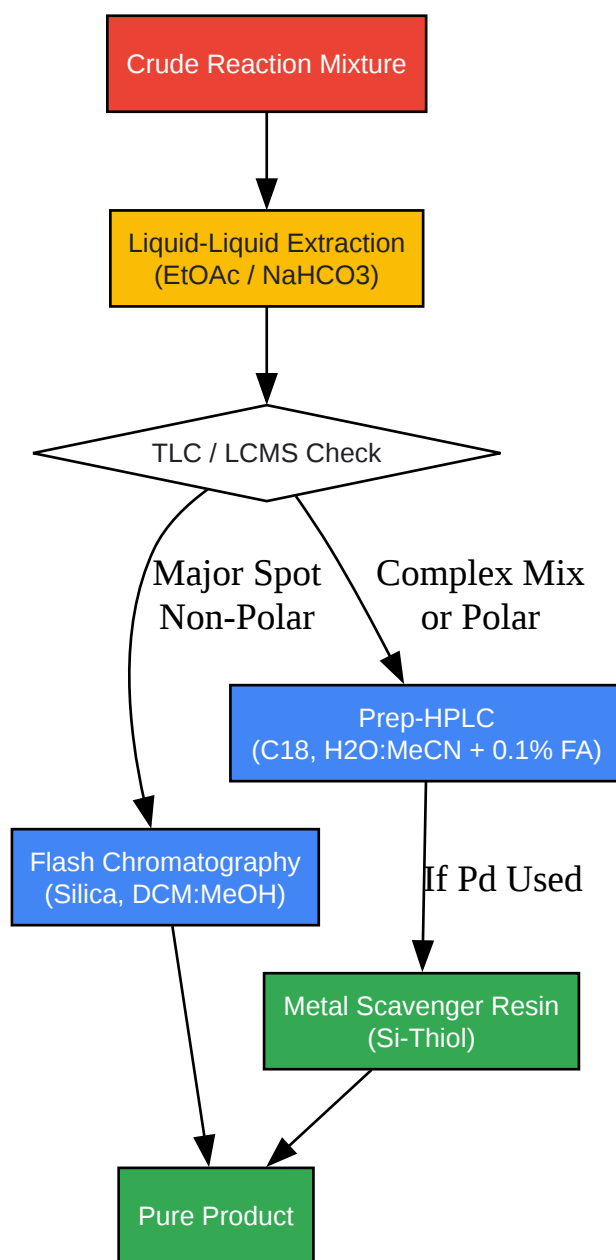

[Click to download full resolution via product page](#)

Figure 2: Purification decision tree for 1-MBA derivatives.

References

- BenchChem.Buchwald-Hartwig Amination of 4-Iodopyrazole Derivatives.[1][5] Application Note. Accessed Oct 2023. [Link](#) (General protocol adaptation).
- Surry, D. S., & Buchwald, S. L. (2008). "Biaryl Phosphane Ligands in Palladium-Catalyzed Amination." *Angewandte Chemie International Edition*, 47(34), 6338–6361. [Link](#) (Ligand selection for heteroaromatic amines).
- Organic Chemistry Portal.Synthesis of Pyrazoles and Reactivity.[Link](#) (General reactivity profiles).
- PubChem.Compound Summary: 1-benzyl-N-methyl-1H-pyrazol-4-amine (Analogous substructure).[1][6][Link](#) (Physical property estimation).
- Sigma-Aldrich.Protocol for Amide Coupling using HATU.[1][Link](#) (Standard operating procedure).

Need Custom Synthesis?

BenchChem offers custom synthesis for rare earth carbides and specific isotopic labeling.

Email: info@benchchem.com or [Request Quote Online](#).

Sources

- 1. CAS#:1248965-89-0 | [(1-Methyl-1H-pyrazol-4-yl)methyl](2-methylbutyl)amine | Chemsrc [m.chemsrc.com]
- 2. Pyrazole synthesis [organic-chemistry.org]
- 3. peptide.com [peptide.com]
- 4. Synthesis of Functionalized Thiophene Based Pyrazole Amides via Various Catalytic Approaches: Structural Features through Computational Applications and Nonlinear Optical Properties - PMC [pmc.ncbi.nlm.nih.gov]
- 5. pdf.benchchem.com [pdf.benchchem.com]
- 6. Pyrazole, 1-benzyl-4-(methylamino)- | C11H13N3 | CID 206698 - PubChem [pubchem.ncbi.nlm.nih.gov]
- To cite this document: BenchChem. [Application Note: High-Fidelity Functionalization of 1-(2-methylbenzyl)-1H-pyrazol-4-amine]. BenchChem, [2026]. [Online PDF]. Available at:

[\[https://www.benchchem.com/product/b3165268/docs#application-note-high-fidelity-functionalization-of-1-2-methylbenzyl-1h-pyrazol-4-amine\]](https://www.benchchem.com/product/b3165268/docs#application-note-high-fidelity-functionalization-of-1-2-methylbenzyl-1h-pyrazol-4-amine)

Disclaimer & Data Validity:

The information provided in this document is for Research Use Only (RUO) and is strictly not intended for diagnostic or therapeutic procedures. While BenchChem strives to provide accurate protocols, we make no warranties, express or implied, regarding the fitness of this product for every specific experimental setup.

Technical Support: The protocols provided are for reference purposes. Unsure if this reagent suits your experiment?

Need Industrial/Bulk Grade? [Request Custom Synthesis Quote](#)

BenchChem

Our mission is to be the trusted global source of essential and advanced chemicals, empowering scientists and researchers to drive progress in science and industry.

Contact

Address: 3281 E Guasti Rd
Ontario, CA 91761, United States
Phone: (601) 213-4426
Email: info@benchchem.com

[Contact our Ph.D. Support Team for a compatibility check](#)