

Aminopyrazole Building Blocks: Regiocontrol, Functionalization, and Medicinal Utility

Author: BenchChem Technical Support Team. **Date:** April 2026

Compound of Interest

Compound Name: *1-[(2-Methylphenyl)methyl]-1H-pyrazol-4-amine*

CAS No.: 898055-82-8

Cat. No.: B3165268

[Get Quote](#)

Executive Summary

The aminopyrazole moiety represents a "privileged scaffold" in modern medicinal chemistry, particularly within the kinase inhibitor space.^{[1][2]} Its capacity to function as a bidentate or tridentate hydrogen bond donor/acceptor pair makes it an ideal mimic of the adenine ring of ATP, allowing it to anchor effectively within the hinge region of kinases such as CDKs, JNKs, and p38 MAPK. However, the utility of aminopyrazoles is frequently bottlenecked by two primary synthetic challenges: regiochemical ambiguity during de novo synthesis (3-amino vs. 5-amino isomers) and catalyst poisoning during late-stage palladium-catalyzed functionalization.

This technical guide provides a rigorous, evidence-based roadmap for navigating these challenges. We detail the kinetic vs. thermodynamic switches required to selectively synthesize 3-amino and 5-amino isomers, provide robust protocols for converting these amines into versatile halide building blocks via the Sandmeyer reaction, and outline strategies for their incorporation into high-affinity drug candidates.

Structural Logic: The Hinge-Binding Motif

The medicinal value of the aminopyrazole core stems from its tautomeric versatility and hydrogen-bonding capability. In the context of kinase inhibition, the 3-aminopyrazole motif typically adopts a binding mode that interacts with the kinase hinge region backbone.[3]

The Donor-Acceptor-Donor (D-A-D) System

The 3-aminopyrazole unit presents a specific electronic face to the receptor:

- Pyridine-like Nitrogen (N2): Acts as a Hydrogen Bond Acceptor (HBA).
- Pyrrole-like Nitrogen (N1): Acts as a Hydrogen Bond Donor (HBD).
- Exocyclic Amine (): Acts as a Hydrogen Bond Donor (HBD).

This arrangement allows for a tight "lock-and-key" fit with the carbonyl and amide backbone residues of the kinase hinge, often determining potency and residence time.

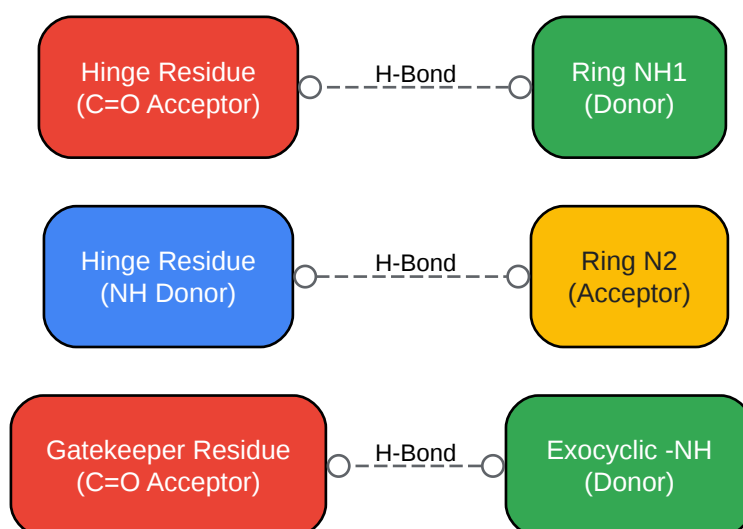

[Click to download full resolution via product page](#)

Caption: Schematic representation of the tridentate hydrogen bonding network between a 3-aminopyrazole core and a generic kinase hinge region.

The Regioselectivity Challenge: 3-Amino vs. 5-Amino

When synthesizing

-substituted aminopyrazoles via the condensation of monosubstituted hydrazines with

-ketonitriles (or alkoxyacrylonitriles), two regioisomers are possible: the 5-aminopyrazole and the 3-aminopyrazole.^{[4][5]} Controlling this outcome is critical, as the two isomers have vastly different biological activities and metabolic profiles.

Mechanistic Divergence

The reaction outcome is governed by the competition between kinetic and thermodynamic control, influenced heavily by the steric bulk of the hydrazine substituent (

) and the reaction temperature.

- Kinetic Control (3-Aminopyrazole):
 - Conditions: Low temperature (), strong base (), short reaction time.
 - Mechanism: The more nucleophilic substituted nitrogen () of the hydrazine attacks the most electrophilic center (the nitrile carbon) first. This leads to the 3-amino isomer.^[6]
 - Note: Electron-donating groups on the hydrazine favor this pathway.^[5]
- Thermodynamic Control (5-Aminopyrazole):
 - Conditions: Reflux (e.g., EtOH,), neutral or acidic conditions.

- o Mechanism: Initial attack may occur at the ketone/enol ether, or the kinetic intermediate equilibrates. The sterically less crowded 5-amino isomer (where the group is distal to the bulky substituent on the pyrazole C3) is thermodynamically preferred.

Experimental Protocol: Regiodivergent Synthesis

Source: Adapted from BenchChem Technical Guide and Fandrick et al. (Org. Lett. 2015) [1, 2]

Parameter	Target: 3-Aminopyrazole (Kinetic)	Target: 5-Aminopyrazole (Thermodynamic)
Solvent	Ethanol (Anhydrous)	Ethanol or Toluene
Base/Additive	(2.0 equiv)	(Cat.) or Neutral
Temperature	(Ice Bath)	- Reflux
Addition Order	Add Electrophile to Hydrazine/Base	Mix reagents, then heat
Reaction Time	2–3 Hours	12–16 Hours
Validation	NOE NMR: Interaction between -substituent and C4-H.	NOE NMR: Interaction between -substituent and C5-substituents.

Critical Validation Step: Never assume regiochemistry based solely on yield. Always perform 2D NOESY NMR. In a 5-aminopyrazole, the

-substituent is spatially close to the amino group (or C5 substituent), whereas in the 3-aminopyrazole, the

-substituent is close to the C5-hydrogen/substituent.

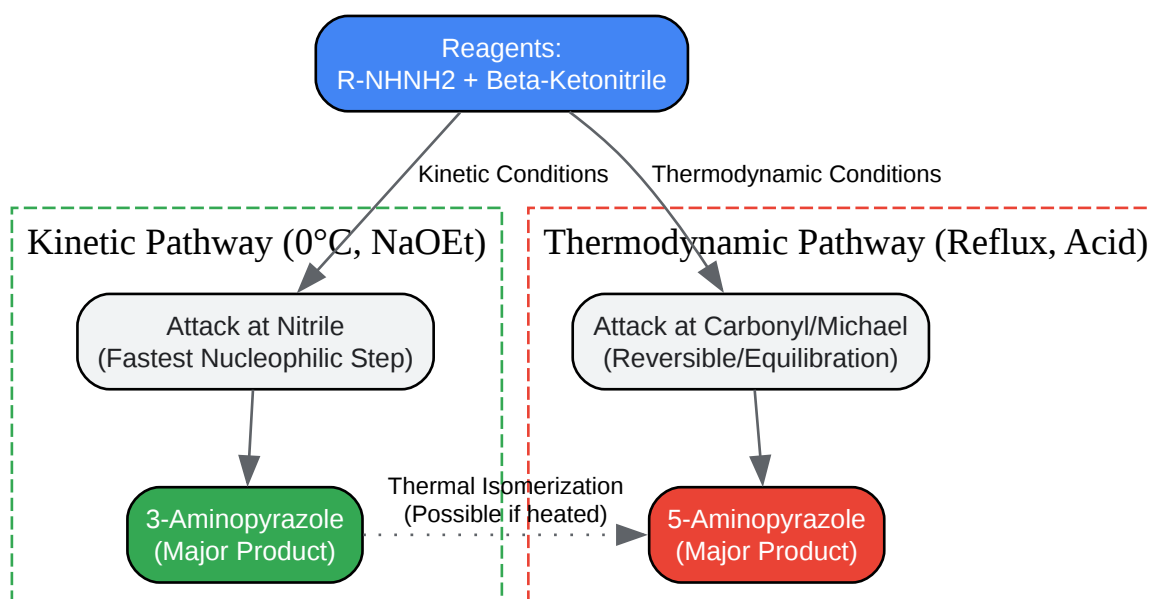

[Click to download full resolution via product page](#)

Caption: Divergent synthetic pathways controlled by reaction temperature and pH, yielding distinct regioisomers.

Functionalization: The Sandmeyer Transformation

While the amino group is essential for H-bonding, it often requires conversion to a halide (Cl, Br, I) to serve as a handle for carbon-carbon bond formation (e.g., Suzuki, Sonogashira coupling) to build complex drug scaffolds. The Sandmeyer reaction is the industry standard for this transformation on pyrazoles.

Protocol: Conversion of 3-Aminopyrazole to 3-Chloropyrazole

This protocol avoids the formation of explosive diazonium salts in solid form by generating them in situ in organic solvents.

Reagents:

- Substrate: 3-Aminopyrazole derivative (1.0 equiv)
- Diazotization Agent: Isoamyl nitrite (2.0 equiv) or tert-butyl nitrite.

- Halogen Source:

(2.0 equiv) for chlorination;

or

for bromination.

- Solvent: Acetonitrile (MeCN).

Step-by-Step Methodology:

- Setup: Charge a round-bottom flask with (anhydrous) and MeCN. Heat to to ensure partial dissolution/suspension.
- Addition: Add isoamyl nitrite dropwise. The solution often turns dark green/black.
- Reaction: Add the 3-aminopyrazole (dissolved in minimal MeCN) dropwise over 30 minutes. Caution: Nitrogen gas evolution will be vigorous.
- Completion: Stir at for 1–2 hours. Monitor by LC-MS (disappearance of M+1 amine peak, appearance of M+1+Cl pattern).
- Workup: Quench with aqueous (to chelate copper). Extract with Ethyl Acetate.^[7]
- Purification: Silica gel chromatography. Halopyrazoles are typically much less polar than the starting amines.

Why this works: The use of organic nitrites (alkyl nitrites) allows the reaction to proceed under non-aqueous or semi-aqueous conditions, which improves solubility of the organic substrate and stabilizes the diazonium intermediate just long enough for the copper halide to effect the radical substitution [3, 4].

Advanced Functionalization: Buchwald-Hartwig Coupling

Direct

-arylation of the exocyclic amine of aminopyrazoles is challenging due to the coordinating ability of the pyrazole nitrogens, which can poison Palladium catalysts. However, modern ligand systems have overcome this.

Recommended Catalyst System:

- Catalyst:

or pre-formed Pd-precatalysts (e.g., BrettPhos Pd G3).

- Ligand: tBuBrettPhos or XPhos. These bulky, electron-rich ligands prevent catalyst deactivation and facilitate the reductive elimination step.

- Base:

(weak base) or

(strong base), depending on the electrophile.

is often used but can cause side reactions with sensitive substrates.

Data Summary: Ligand Efficiency for Aminopyrazole Arylation Source: Adapted from comparative studies (e.g., J. Org. Chem. 2014) [5][8]

Ligand	Substrate Scope	Yield (Avg)	Notes
BINAP	Limited	20-40%	Often fails with unprotected pyrazoles.
XPhos	Broad	75-85%	Excellent for aryl chlorides.
tBuBrettPhos	Very Broad	>90%	Best for heteroaryl halides and hindered substrates.

Medicinal Applications: Case Study in Selectivity

The development of JNK3 inhibitors highlights the power of the aminopyrazole scaffold. Researchers at Scripps and other institutes utilized the scaffold to differentiate between JNK3 and the closely related p38 MAPK.

- Challenge: JNK3 and p38 share high sequence homology in the ATP binding site.
- Solution: The 3-aminopyrazole scaffold (e.g., in compound SR-3576) is highly planar. The -linked phenyl group on the pyrazole occupies a specific hydrophobic pocket.
- Result: While indazole-based inhibitors inhibited both kinases, the aminopyrazole derivatives showed >1000-fold selectivity for JNK3 over p38.^{[9][10]} This was attributed to the specific "induced fit" allowed by the rotatable -phenyl bond of the aminopyrazole, which was constrained in the fused indazole system ^[6].

Summary of Key Aminopyrazole Drugs/Leads

- Avapritinib: Targets KIT/PDGFRα. Uses a pyrazole core to position substituents.^{[1][3][11]}
- AT7519: A CDK inhibitor.^{[3][6]} Uses the pyrazole-3-carboxamide (related to aminopyrazole) to bind the hinge.

- Celecoxib: A 1,5-diaryl-3-trifluoromethylpyrazole (demonstrates the 1,5-regiochemistry importance, though not an aminopyrazole per se, it utilizes the same synthetic logic).

References

- A Technical Guide to the Regioselective Synthesis of Substituted Aminopyrazoles. BenchChem. [Link](#)
- Fandrick, D. R., et al.[4] "A Michael Equilibration Model to Control Site Selectivity in the Condensation toward Aminopyrazoles." Organic Letters, 2015, 17(12), 2964–2967. [Link](#)
- Synthesis of 3-Chloro-1H-pyrazole from 3-Aminopyrazole: A Technical Guide. BenchChem. [Link](#)
- Beletskaya, I. P., et al. "Catalytic Sandmeyer Bromination." [12] Synthesis, 2007, 2534-2538. [12] [Link](#)
- Palladium-Catalyzed Amination of Unprotected Five-Membered Heterocyclic Bromides. Journal of Organic Chemistry, 2014. [Link](#)
- Kamenecka, T. M., et al. "Structure-Activity Relationships and X-ray Structures Describing the Selectivity of Aminopyrazole Inhibitors for c-Jun N-terminal Kinase 3 (JNK3) over p38." Journal of Biological Chemistry, 2009. [Link](#)

Need Custom Synthesis?

BenchChem offers custom synthesis for rare earth carbides and specific isotopic labeling.

Email: info@benchchem.com or [Request Quote Online](#).

Sources

- 1. Amino-Pyrazoles in Medicinal Chemistry: A Review [unige.iris.cineca.it]
- 2. Amino-Pyrazoles in Medicinal Chemistry: A Review - PubMed [pubmed.ncbi.nlm.nih.gov]
- 3. Synthesis of aminopyrazole analogs and their evaluation as CDK inhibitors for cancer therapy - PMC [pmc.ncbi.nlm.nih.gov]
- 4. Thieme E-Journals - Synfacts / Abstract [thieme-connect.com]

- [5. benchchem.com \[benchchem.com\]](https://www.benchchem.com)
- [6. mdpi.com \[mdpi.com\]](https://www.mdpi.com)
- [7. pdf.benchchem.com \[pdf.benchchem.com\]](https://pdf.benchchem.com)
- [8. Palladium-Catalyzed Amination of Unprotected Five-Membered Heterocyclic Bromides - PMC \[pmc.ncbi.nlm.nih.gov\]](https://pubmed.ncbi.nlm.nih.gov/3165268/)
- [9. semanticscholar.org \[semanticscholar.org\]](https://www.semanticscholar.org)
- [10. Structure-activity relationships and X-ray structures describing the selectivity of aminopyrazole inhibitors for c-Jun N-terminal kinase 3 \(JNK3\) over p38 - PubMed \[pubmed.ncbi.nlm.nih.gov\]](https://pubmed.ncbi.nlm.nih.gov/3165268/)
- [11. scirp.org \[scirp.org\]](https://www.scirp.org)
- [12. Sandmeyer Reaction \[organic-chemistry.org\]](https://www.organic-chemistry.org)
- To cite this document: BenchChem. [Aminopyrazole Building Blocks: Regiocontrol, Functionalization, and Medicinal Utility]. BenchChem, [2026]. [Online PDF]. Available at: [<https://www.benchchem.com/product/b3165268/docs#aminopyrazole-building-blocks-regiocontrol-functionalization-and-medicinal-utility>]

Disclaimer & Data Validity:

The information provided in this document is for Research Use Only (RUO) and is strictly not intended for diagnostic or therapeutic procedures. While BenchChem strives to provide accurate protocols, we make no warranties, express or implied, regarding the fitness of this product for every specific experimental setup.

Technical Support: The protocols provided are for reference purposes. Unsure if this reagent suits your experiment?

Need Industrial/Bulk Grade? [Request Custom Synthesis Quote](#)

BenchChem

Our mission is to be the trusted global source of essential and advanced chemicals, empowering scientists and researchers to drive progress in science and industry.

Contact

Address: 3281 E Guasti Rd

Ontario, CA 91761, United States

Phone: (601) 213-4426

Email: info@benchchem.com

[Contact our Ph.D. Support Team for a compatibility check](#)