

# Technical Support Center: Controlling Keto-Enol Tautomerism in Pyrazolone NMR Analysis

**Author:** BenchChem Technical Support Team. **Date:** April 2026

## Compound of Interest

Compound Name: 5-(3-Methoxy-phenyl)-2,4-dihydro-pyrazol-3-one

CAS No.: 886494-11-7

Cat. No.: B3163842

[Get Quote](#)

Welcome to the technical support center for researchers, scientists, and drug development professionals. This guide is designed to provide in-depth, practical solutions for controlling and analyzing the keto-enol tautomerism of pyrazolone derivatives using Nuclear Magnetic Resonance (NMR) spectroscopy. Pyrazolones are a critical class of compounds in medicinal chemistry, and understanding their tautomeric behavior is paramount for structure elucidation, reaction monitoring, and drug design.<sup>[1][2][3]</sup>

This resource is structured into two main sections: a Troubleshooting Guide to address specific experimental challenges, and a Frequently Asked Questions (FAQs) section for broader conceptual understanding.

## Understanding Pyrazolone Tautomerism

Pyrazolone derivatives can exist in a dynamic equilibrium between several tautomeric forms. For a typical 1-substituted-3-methyl-5-pyrazolone (like the well-known drug Edaravone), three primary tautomers are considered: the keto (CH), enol (OH), and a third zwitterionic/amine

(NH) form.<sup>[4][5][6][7]</sup> The equilibrium between these forms is highly sensitive to the surrounding environment.

## Troubleshooting Guide

This section is formatted to help you quickly identify and solve specific problems you may encounter during your NMR analysis.

Question 1: My <sup>1</sup>H NMR spectrum shows more signals than I expected for my pyrazolone compound. What's happening?

This is a classic sign that your compound exists as a mixture of tautomers in the NMR solvent you are using.<sup>[8]</sup> Because the keto, enol, and NH forms are structurally distinct, they will give rise to different sets of NMR signals. The rate of interconversion between these tautomers on the NMR timescale will determine the appearance of your spectrum.

- **Slow Exchange:** If the tautomers are interconverting slowly, you will see sharp, distinct sets of peaks for each populated form.
- **Intermediate Exchange:** If the interconversion rate is comparable to the NMR timescale, you will observe broad, poorly resolved signals.
- **Fast Exchange:** If the interconversion is rapid, you will see a single set of sharp, averaged signals.

Troubleshooting Steps:

- **Change the Solvent:** The tautomeric equilibrium is highly dependent on the solvent.<sup>[1][9][10]</sup> Run the NMR in a different deuterated solvent to see if you can favor one form and simplify the spectrum. For example, non-polar aprotic solvents like CDCl<sub>3</sub> often favor the keto (CH) form, while polar, hydrogen-bond-accepting solvents like DMSO-d<sub>6</sub> can stabilize the enol (OH) and NH forms, leading to a mixture.<sup>[4][9][11]</sup>
- **Variable Temperature (VT) NMR:** Acquiring spectra at different temperatures is a powerful tool to study dynamic processes.<sup>[8][12]</sup>

- Increasing Temperature: Often increases the rate of interconversion, which can cause broad signals from an intermediate exchange regime to coalesce and sharpen into a single, averaged set of peaks.
- Decreasing Temperature: Can slow down the exchange rate, potentially resolving averaged or broad signals into distinct sets of sharp peaks for each tautomer.[12]
- Use 2D NMR: Two-dimensional NMR experiments like HSQC and HMBC are invaluable for assigning signals in a complex mixture. They can help you confirm the presence of multiple distinct spin systems (i.e., different tautomers) and assign the carbons and protons for each form.[8]

Question 2: I see a very broad signal in the 10-14 ppm range of my  $^1\text{H}$  NMR spectrum. What is it and how can I confirm it?

A broad signal in this downfield region is typically characteristic of the acidic N-H or O-H proton of the pyrazolone ring.[8] The broadening is caused by two main factors:

- Chemical Exchange: The acidic proton can exchange with other labile protons in the sample (like trace amounts of water in the solvent) or between pyrazolone molecules. This rapid exchange shortens the proton's relaxation time, leading to a broader signal.[8]
- Quadrupolar Broadening: The proton is attached to a nitrogen atom ( $^{14}\text{N}$ ), which has a nuclear quadrupole moment. This provides an efficient relaxation mechanism that significantly broadens the signal of the attached proton.[8]

Confirmation Step:

- D<sub>2</sub>O Exchange: To definitively prove the signal is from an exchangeable N-H or O-H proton, add a single drop of deuterium oxide (D<sub>2</sub>O) to your NMR tube, shake it gently, and re-acquire the  $^1\text{H}$  NMR spectrum. The broad signal should disappear or significantly decrease in intensity as the labile protons are replaced by deuterium, which is not observed in  $^1\text{H}$  NMR.

Question 3: How can I intentionally shift the tautomeric equilibrium to favor a single form for my analysis or reaction?

Controlling the equilibrium is key. You can manipulate the experimental conditions to drive the equilibrium towards the desired tautomer.

- To Favor the Keto (CH) Form: Use a non-polar, aprotic solvent like chloroform-d ( $\text{CDCl}_3$ ) or benzene- $\text{d}_6$ .<sup>[4][9][13]</sup> These solvents do not effectively solvate the polar enol or NH forms, thus favoring the less polar keto tautomer.
- To Favor the Enol (OH) Form: Use a polar, hydrogen-bond-accepting solvent like DMSO- $\text{d}_6$  or pyridine- $\text{d}_5$ .<sup>[4][9]</sup> These solvents can stabilize the enol form through intermolecular hydrogen bonding.
- pH Adjustment: The tautomerism can be influenced by pH. While not always practical for standard NMR, adding a trace amount of acid or base can shift the equilibrium. For instance, basic conditions can deprotonate the pyrazolone, favoring the enolate, which is an intermediate in the tautomerization process.

## Frequently Asked Questions (FAQs)

Q1: What are the typical  $^1\text{H}$  and  $^{13}\text{C}$  NMR chemical shifts for the different pyrazolone tautomers?

While the exact chemical shifts are highly dependent on the specific substituents and the solvent used, some general ranges can be provided. The following table summarizes typical chemical shifts for a 1-phenyl-3-methyl-5-pyrazolone system.

Tautomer	Group	Typical $^1\text{H}$ $\delta$ (ppm)	Typical $^{13}\text{C}$ $\delta$ (ppm)	Notes
Keto (CH)	C4-H <sub>2</sub>	~3.4	~43	Methylene protons appear as a singlet.
C4	~43	~171		
C5=O	-	~171	Carbonyl carbon is significantly downfield.	
Enol (OH)	C4-H	~5.2 - 6.1	~85 - 97	Vinylic proton appears as a singlet.
OH	~10.0 - 12.5	-	Often broad; chemical shift is concentration and solvent dependent.	
C4	~85 - 97	~158 - 161		
C5-OH	-	~158 - 161	Enolic carbon is deshielded.	
NH Form	C4-H <sub>2</sub>	~3.5	~40	Similar to keto form but can be distinguished by other signals.
NH	~9.0 - 11.0	-	Broad signal.	
C4	~40	~155		
C5	-	~155		

Note: These are approximate values. Data is compiled from multiple sources and may vary.[\[4\]](#)  
[\[9\]](#)[\[11\]](#)[\[14\]](#)

Q2: How do substituents on the pyrazolone ring affect the tautomeric equilibrium?

Substituents can have a profound electronic effect on the stability of the different tautomers.[15]

- **Electron-Withdrawing Groups (EWGs):** At the C3 or C5 positions, EWGs like -CHO or -COOH tend to stabilize the keto form by increasing the acidity of the C4 protons.[15]
- **Electron-Donating Groups (EDGs):** At the C3 or C5 positions, EDGs like -NH<sub>2</sub> or -CH<sub>3</sub> can stabilize the enol form by donating electron density into the ring, making the enol double bond more stable.[15]
- **N1-Substituent:** The nature of the substituent on the N1 nitrogen also plays a crucial role, influencing the overall electron density and steric environment of the ring system.[1]

Q3: Can I use NMR to calculate the ratio of tautomers in my sample?

Absolutely. Once you have assigned the signals for each tautomer, you can use the integration values from the <sup>1</sup>H NMR spectrum to determine their relative populations.

Protocol for Quantifying Tautomer Ratios:

- **Acquire a High-Quality <sup>1</sup>H NMR Spectrum:** Ensure good signal-to-noise and proper phasing and baseline correction.
- **Identify Non-Overlapping Signals:** Choose a well-resolved signal that is unique to each tautomer. For example, the C4-H<sub>2</sub> signal for the keto form and the C4-H signal for the enol form.
- **Integrate the Signals:** Carefully integrate the chosen signals. The integration value is directly proportional to the number of protons giving rise to that signal.
- **Calculate the Ratio:** Divide the integration value of each signal by the number of protons it represents. For example, if you integrate the C4-H<sub>2</sub> singlet of the keto form (representing 2 protons) and the C4-H singlet of the enol form (representing 1 proton), you would divide the keto integral by 2. The resulting values will be proportional to the molar ratio of the tautomers.

- Example Calculation:
  - Integral of Keto C4-H<sub>2</sub> (2H) = 1.50
  - Integral of Enol C4-H (1H) = 0.75
  - Normalized Keto =  $1.50 / 2 = 0.75$
  - Normalized Enol =  $0.75 / 1 = 0.75$
  - Ratio of Keto : Enol =  $0.75 : 0.75 = 1 : 1$  or 50% Keto, 50% Enol.

## Experimental Protocols & Visualizations

### Protocol: Sample Preparation to Favor a Specific Tautomer

This protocol describes how to prepare two separate NMR samples of the same pyrazolone compound to preferentially populate the keto and enol forms.

Objective: To simplify the NMR spectrum by isolating one dominant tautomer.

Materials:

- Pyrazolone compound
- Deuterated chloroform (CDCl<sub>3</sub>)
- Deuterated dimethyl sulfoxide (DMSO-d<sub>6</sub>)
- Two clean, dry NMR tubes
- Micropipette and analytical balance

Procedure:

- Sample for Keto Form Analysis: a. Accurately weigh approximately 5-10 mg of your pyrazolone compound into the first NMR tube. b. Add approximately 0.6 mL of CDCl<sub>3</sub> to the

tube. c. Cap the tube and gently vortex or invert until the sample is fully dissolved. This sample is expected to favor the keto (CH) tautomer.[4][9]

- Sample for Enol/Mixed Form Analysis: a. Accurately weigh approximately 5-10 mg of your pyrazolone compound into the second NMR tube. b. Add approximately 0.6 mL of DMSO- $d_6$  to the tube. c. Cap the tube and gently vortex or invert until the sample is fully dissolved. This sample is expected to show a higher population of the enol (OH) tautomer, often in equilibrium with other forms.[4][16]
- NMR Acquisition: a. Acquire standard  $^1H$ ,  $^{13}C$ , and, if necessary, 2D NMR (HSQC, HMBC) spectra for both samples. b. Compare the spectra to identify the chemical shifts corresponding to each dominant tautomer.

## Diagrams

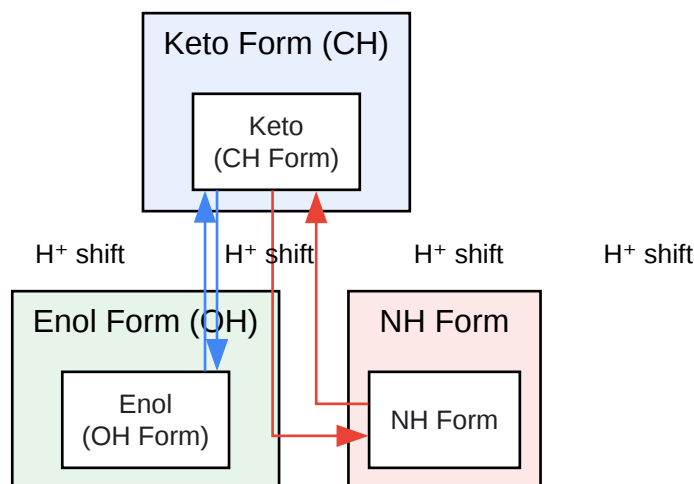

[Click to download full resolution via product page](#)

Caption: Prototropic equilibrium between the major pyrazolone tautomers.

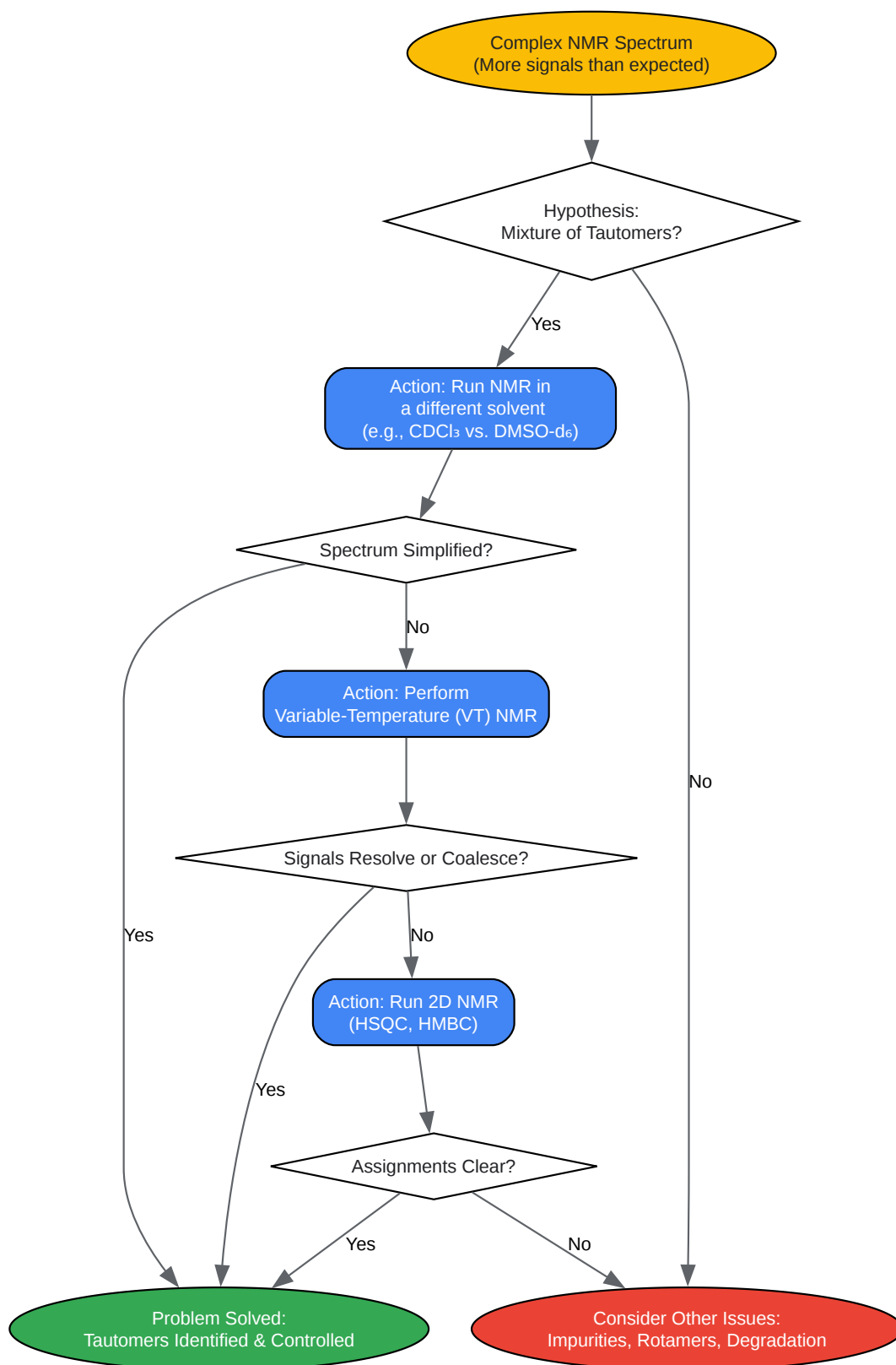

[Click to download full resolution via product page](#)

Caption: Troubleshooting workflow for a complex pyrazolone NMR spectrum.

## References

- Gürbüz, D., et al. (2020). Preparative, mechanistic and tautomeric investigation of 1-phenyl and 1-methyl derivative of 3-methyl-5-pyrazolone. Journal of the Serbian Chemical Society. Available at: [\[Link\]](#)
- Guedes, R. C., et al. (2019). Revisiting the Structure and Chemistry of 3(5)-Substituted Pyrazoles. *Molecules*, 25(1), 35. Available at: [\[Link\]](#)
- ResearchGate (n.d.). Preparative, mechanistic and tautomeric investigation of 1-phenyl and 1-methyl derivative of 3-methyl-5-pyrazolone | Request PDF. ResearchGate. Available at: [\[Link\]](#)
- Abraham, R. J., et al. (2018). The Use of MM/QM calculations of <sup>13</sup>C chemical shifts in the analysis of Edaravone tautomers. *Magnetic Resonance in Chemistry*, 56(10), 965-972. Available at: [\[Link\]](#)
- Kappe, C. O., et al. (2017). On the Tautomerism of N-Substituted Pyrazolones: 1,2-Dihydro-3H-pyrazol-3-ones versus 1H-Pyrazol-3-ols. *Molecules*, 22(5), 779. Available at: [\[Link\]](#)
- Elguero, J., et al. (1992). The Tautomerism of 3(5)-Phenylpyrazoles: An Experimental (<sup>1</sup>H, <sup>13</sup>C, <sup>15</sup>N NMR and X-Ray Crystallography) Study. *Journal of the Chemical Society, Perkin Transactions 2*, (10), 1739-1746. Available at: [\[Link\]](#)
- Al-Hourani, B. J., et al. (2018). Tautomerism and antioxidant activity of some 4-acylpyrazolone-based Schiff bases: a theoretical study. *New Journal of Chemistry*, 42(19), 15967-15975. Available at: [\[Link\]](#)
- ResearchGate (n.d.). (a) Possible tautomers of 3-methyl-1-phenyl-1H-pyrazol-5(4H)-one 1 a... ResearchGate. Available at: [\[Link\]](#)
- ResearchGate (n.d.). On the tautomerism of pyrazolones: The geminal 2J[pyrazole C-4,H-3(5)] spin coupling constant as a diagnostic tool | Request PDF. ResearchGate. Available at: [\[Link\]](#)
- ResearchGate (n.d.). (PDF) The Use of MM/QM Calculations of <sup>13</sup>C Chemical Shifts in the Analysis of Edaravone Tautomers. ResearchGate. Available at: [\[Link\]](#)

- ResearchGate (n.d.). Tautomers of 3-methyl-1-phenyl-5-pyrazolone 1 and 4,4'-(arylmethylene)bis(1H-pyrazol-5-ols) 3. ResearchGate. Available at: [\[Link\]](#)
- Abood, N. A., et al. (2012). Theoretical study of molecular structure, IR and NMR spectra of pyrazolone and its derivatives. *Journal of Chemical and Pharmaceutical Research*, 4(3), 1772-1781. Available at: [\[Link\]](#)
- ChemRxiv (2020). Synthesis and Characterization of New Formylpyrazolones and Schiff bases. ChemRxiv. Available at: [\[Link\]](#)
- El-Toukby, M. A., et al. (2012). Pyrazol-5-ones: Tautomerism, Synthesis and Reactions. *ChemInform*, 43(8). Available at: [\[Link\]](#)
- Abboud, J. L. M., et al. (1997). Theoretical calculations on pyrazole derivatives. Part 2. Effect of cationic C-substituents (NH<sub>3</sub><sup>+</sup> and N<sub>2</sub><sup>+</sup>) on the basicity and tautomerism of pyrazoles. *Journal of the Chemical Society, Perkin Transactions 2*, (2), 263-268. Available at: [\[Link\]](#)
- Kappe, C. O., et al. (2011). reactions and tautomeric behavior of 1-(2-pyridinyl)- 1h-pyrazol-5-ols. *HETEROCYCLES*, 83(7), 1569-1586. Available at: [\[Link\]](#)
- Pazdera, P., et al. (2014). Use of activated enol ethers in the synthesis of pyrazoles: reactions with hydrazine and a study of pyrazole tautomerism. *Beilstein Journal of Organic Chemistry*, 10, 784-796. Available at: [\[Link\]](#)
- ResearchGate (n.d.). Theoretical studies on tautomerism and IR spectra of pyrazole derivatives. ResearchGate. Available at: [\[Link\]](#)
- AIR Unimi (2023). Synthesis and Characterization of Edaravone Analogues as Remyelinating Agents and Putative Mechanistic Probes. AIR Unimi. Available at: [\[Link\]](#)
- SSRN (2023). Structural Characterization and Keto-Enol Tautomerization of 4-Substituted Pyrazolone Derivatives with Dft Approach. SSRN. Available at: [\[Link\]](#)
- PubMed (2024). Structural characterization and keto-enol tautomerization of 4-substituted pyrazolone derivatives with DFT approach. PubMed. Available at: [\[Link\]](#)

- MDPI (2023). Synthesis and Characterization of Edaravone Analogues as Remyelinating Agents and Putative Mechanistic Probes. MDPI. Available at: [\[Link\]](#)
- ResearchGate (n.d.). (PDF) The tautomerism of pyrazolines (dihydropyrazoles). ResearchGate. Available at: [\[Link\]](#)
- ResearchGate (n.d.). Theoretical NMR investigation of pyrazol and substituted pyrazoles, DNMR and 1 H spin-lattice relaxation times. ResearchGate. Available at: [\[Link\]](#)
- Al-Majedy, Y. K., et al. (2020). Synthesis, Spectroscopic Studies and Keto-Enol Tautomerism of Novel 1,3,4-Thiadiazole Derivative Containing 3-Mercaptobutan-2-one and Quinazolin-4-one Moieties. Molecules, 25(22), 5469. Available at: [\[Link\]](#)
- Elguero, J., et al. (2002). The Use of NMR Spectroscopy to Study Tautomerism. Annual Reports on NMR Spectroscopy, 48, 1-133. Available at: [\[Link\]](#)
- Reddit (2024). 1H NMR of pyrazole. Reddit. Available at: [\[Link\]](#)
- ResearchGate (n.d.). Example 1 H NMR spectrum of pyrazoline protons (Ha, Hb and Hx). ResearchGate. Available at: [\[Link\]](#)

### Need Custom Synthesis?

BenchChem offers custom synthesis for rare earth carbides and specific isotopic labeling.

Email: [info@benchchem.com](mailto:info@benchchem.com) or [Request Quote Online](#).

## Sources

- [1. jocpr.com \[jocpr.com\]](#)
- [2. researchgate.net \[researchgate.net\]](#)
- [3. triggered.stanford.clockss.org \[triggered.stanford.clockss.org\]](#)
- [4. ias.ac.in \[ias.ac.in\]](#)
- [5. pdf.benchchem.com \[pdf.benchchem.com\]](#)
- [6. researchgate.net \[researchgate.net\]](#)

- [7. researchgate.net \[researchgate.net\]](#)
- [8. pdf.benchchem.com \[pdf.benchchem.com\]](#)
- [9. DSpace \[bradscholars.brad.ac.uk\]](#)
- [10. pdf.benchchem.com \[pdf.benchchem.com\]](#)
- [11. On the Tautomerism of N-Substituted Pyrazolones: 1,2-Dihydro-3H-pyrazol-3-ones versus 1H-Pyrazol-3-ols - PMC \[pmc.ncbi.nlm.nih.gov\]](#)
- [12. userpage.fu-berlin.de \[userpage.fu-berlin.de\]](#)
- [13. researchgate.net \[researchgate.net\]](#)
- [14. researchgate.net \[researchgate.net\]](#)
- [15. Revisiting the Structure and Chemistry of 3\(5\)-Substituted Pyrazoles - PMC \[pmc.ncbi.nlm.nih.gov\]](#)
- [16. researchgate.net \[researchgate.net\]](#)
- [To cite this document: BenchChem. \[Technical Support Center: Controlling Keto-Enol Tautomerism in Pyrazolone NMR Analysis\]. BenchChem, \[2026\]. \[Online PDF\]. Available at: \[https://www.benchchem.com/product/b3163842/docs#technical-support-center-controlling-keto-enol-tautomerism-in-pyrazolone-nmr-analysis\]](#)

---

#### Disclaimer & Data Validity:

The information provided in this document is for Research Use Only (RUO) and is strictly not intended for diagnostic or therapeutic procedures. While BenchChem strives to provide accurate protocols, we make no warranties, express or implied, regarding the fitness of this product for every specific experimental setup.

**Technical Support:** The protocols provided are for reference purposes. Unsure if this reagent suits your experiment?

**Need Industrial/Bulk Grade?** [Request Custom Synthesis Quote](#)

# BenchChem

Our mission is to be the trusted global source of essential and advanced chemicals, empowering scientists and researchers to drive progress in science and industry.

## Contact

Address: 3281 E Guasti Rd

Ontario, CA 91761, United States

Phone: (601) 213-4426

Email: [info@benchchem.com](mailto:info@benchchem.com)

[Contact our Ph.D. Support Team for a compatibility check](#)