

Technical Support Center: Addressing Matrix Effects in LC-MS Analysis

Author: BenchChem Technical Support Team. **Date:** April 2026

Compound of Interest

Compound Name: 5-Hydroxy-2-(trifluoromethoxy)benzoic acid
CAS No.: 851341-57-6
Cat. No.: B3157686

[Get Quote](#)

Welcome to the technical support center for addressing matrix effects in Liquid Chromatography-Mass Spectrometry (LC-MS) analysis. This guide is designed for researchers, scientists, and drug development professionals who encounter the challenges of matrix interference in their quantitative studies. Here, we will delve into the causes of matrix effects, provide robust troubleshooting guides, and answer frequently asked questions to help you ensure the accuracy and reliability of your LC-MS data.

I. Frequently Asked Questions (FAQs)

This section provides direct answers to the most common questions regarding matrix effects in LC-MS analysis.

Q1: What is the "matrix effect" in LC-MS analysis?

A: The matrix effect refers to the alteration of an analyte's ionization efficiency due to the presence of co-eluting, undetected components in the sample matrix.^{[1][2][3]} This phenomenon can lead to either ion suppression (a decrease in the analyte signal) or ion enhancement (an increase in the analyte signal), both of which compromise the accuracy and precision of

quantitative analysis.[4][5] The "matrix" itself encompasses all components within a sample other than the analyte of interest, such as proteins, lipids, salts, and other endogenous compounds.[1]

Q2: What are the primary causes of matrix effects?

A: Matrix effects primarily arise from competition between the analyte and co-eluting matrix components for ionization in the MS source.[2] In electrospray ionization (ESI), for instance, compounds with higher proton affinity or surface activity can preferentially ionize, suppressing the ionization of the target analyte.[6] Other causes include:

- Changes in droplet formation and solvent evaporation: High concentrations of non-volatile matrix components can alter the physical properties of the ESI droplets, hindering the release of analyte ions into the gas phase.[6]
- Ion-pairing interactions: Matrix components can form adducts with the analyte, altering its charge state and, consequently, its detection.
- Space-charge effects: A high density of ions in the ion source can lead to charge repulsion, affecting the transmission of analyte ions into the mass analyzer.[6]

Q3: How can I determine if my analysis is affected by matrix effects?

A: Several methods can be employed to assess the presence and extent of matrix effects. The most common are the post-column infusion experiment and the post-extraction spike method.[7]

- Post-Column Infusion: This qualitative technique involves continuously infusing a standard solution of the analyte into the MS while injecting an extracted blank matrix sample onto the LC column. Any dip or rise in the constant analyte signal indicates the retention time at which matrix components are eluting and causing ion suppression or enhancement.[4]
- Post-Extraction Spike (Matrix Factor Assessment): This quantitative method is considered the "gold standard". It involves comparing the peak area of an analyte spiked into an extracted blank matrix with the peak area of the same analyte in a neat (pure) solvent. The ratio of these peak areas is the Matrix Factor (MF). An MF of 1 indicates no matrix effect, <1

indicates ion suppression, and >1 indicates ion enhancement. Regulatory guidelines often suggest that the MF should be within a certain range (e.g., 0.85 to 1.15) with a precision (%CV) of less than 15%.^[4]

Q4: What is a Stable Isotope-Labeled Internal Standard (SIL-IS), and how does it help?

A: A Stable Isotope-Labeled Internal Standard (SIL-IS) is a version of the analyte where one or more atoms have been replaced with their heavier, non-radioactive isotopes (e.g., ^2H , ^{13}C , ^{15}N). A SIL-IS is considered the gold standard for internal standards in LC-MS because it has nearly identical chemical and physical properties to the analyte.^[8] This means it will co-elute with the analyte and experience the same degree of matrix effect.^[8] By calculating the ratio of the analyte's peak area to the SIL-IS's peak area, the variability caused by matrix effects can be effectively compensated for, leading to more accurate and precise quantification.^[1]

Q5: Are there any limitations to using a SIL-IS?

A: While highly effective, SIL-ISs are not a panacea. A key consideration is the potential for chromatographic separation between the analyte and the SIL-IS, often due to the "deuterium isotope effect" when deuterium is used for labeling. If the SIL-IS does not perfectly co-elute with the analyte, they may experience different degrees of ion suppression or enhancement, leading to inaccurate results. Additionally, the isotopic purity of the SIL-IS is crucial to avoid interference with the analyte signal.^[9]

II. Troubleshooting Guides

This section provides detailed, step-by-step guidance to identify, quantify, and mitigate matrix effects in your LC-MS experiments.

Guide 1: Systematic Evaluation of Matrix Effects

A thorough assessment of matrix effects is a critical component of method development and validation, as emphasized by regulatory bodies like the FDA and EMA.^{[4][10]}

Protocol 1: Post-Column Infusion Experiment

Objective: To qualitatively identify the regions in the chromatogram where matrix effects (ion suppression or enhancement) occur.

Methodology:

- System Setup:
 - Prepare a standard solution of your analyte at a concentration that provides a stable and mid-range signal on your mass spectrometer.
 - Using a T-fitting, connect a syringe pump to infuse the analyte solution post-column, before the ESI probe.
 - Set the infusion flow rate to be a small fraction of the LC flow rate (e.g., 10 μ L/min for a 0.5 mL/min LC flow).
- Data Acquisition:
 - Begin infusing the analyte solution and acquire data on the mass spectrometer to establish a stable baseline signal.
 - Inject a prepared blank matrix sample (extracted using your sample preparation protocol) onto the LC system.
 - Monitor the analyte's signal throughout the chromatographic run.
- Data Interpretation:
 - A stable, flat baseline indicates no matrix effects.
 - A decrease in the baseline signal at a specific retention time indicates ion suppression.
 - An increase in the baseline signal indicates ion enhancement.

Diagram: Post-Column Infusion Workflow

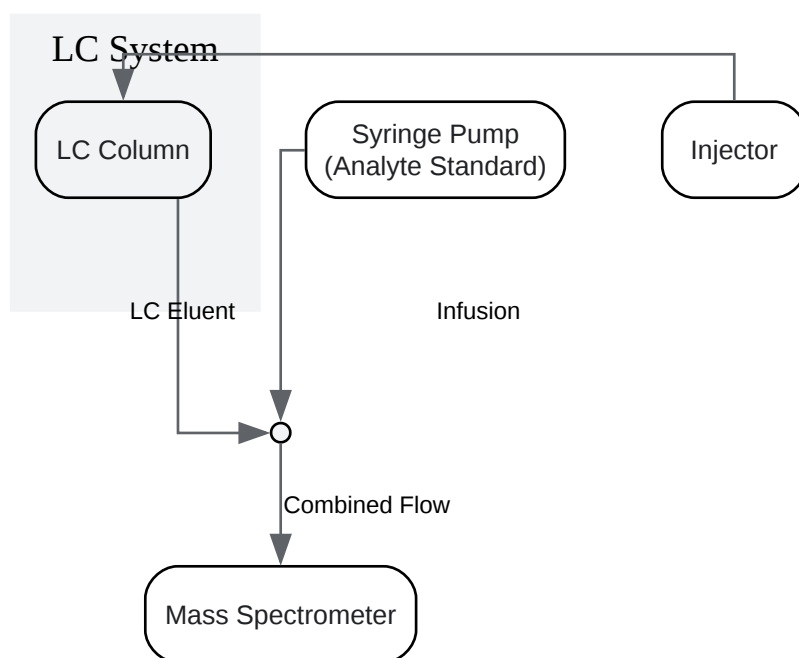

[Click to download full resolution via product page](#)

Caption: Workflow for the post-column infusion experiment.

Protocol 2: Quantitative Assessment using Matrix Factor (MF)

Objective: To quantify the degree of ion suppression or enhancement.

Methodology:

- Prepare Three Sets of Samples (at low and high QC concentrations):
 - Set A (Neat Solution): Spike the analyte and internal standard (IS) into the final reconstitution solvent.
 - Set B (Post-Extraction Spike): Extract at least six different lots of blank matrix. Spike the analyte and IS into the final extracted matrix supernatant/eluante.
 - Set C (Pre-Extraction Spike): Spike the analyte and IS into the blank matrix before the extraction process (used for recovery calculation).
- Analysis: Analyze all three sets of samples by LC-MS.

- Calculations:
 - Matrix Factor (MF):
 - $MF = (\text{Mean Peak Area of Analyte in Set B}) / (\text{Mean Peak Area of Analyte in Set A})$
 - An MF close to 1.0 indicates minimal matrix effect.
 - IS-Normalized MF:
 - $IS\text{-Normalized MF} = (\text{Mean Analyte/IS Peak Area Ratio in Set B}) / (\text{Mean Analyte/IS Peak Area Ratio in Set A})$
 - This value demonstrates the ability of the IS to compensate for the matrix effect.
 - Recovery:
 - $\% \text{ Recovery} = (\text{Mean Peak Area of Analyte in Set C}) / (\text{Mean Peak Area of Analyte in Set B}) * 100$

Data Presentation: Interpreting Matrix Factor and Recovery

Parameter	Calculation	Ideal Value	Interpretation
Matrix Factor (MF)	Peak Area (Post-Spike) / Peak Area (Neat)	1.0 (typically 0.85-1.15)	Quantifies ion suppression (<1) or enhancement (>1).[7]
IS-Normalized MF	Area Ratio (Post-Spike) / Area Ratio (Neat)	1.0 (typically 0.85-1.15)	Assesses the IS's ability to track and correct for matrix effects.
Recovery	Peak Area (Pre-Spike) / Peak Area (Post-Spike)	Consistent and reproducible	Measures the efficiency of the sample extraction process.

Guide 2: Strategies for Mitigating Matrix Effects

If significant matrix effects are identified, the following strategies, often used in combination, can be employed to minimize their impact.

Strategy 1: Chromatographic Separation

The most straightforward approach is to chromatographically separate the analyte from the interfering matrix components.

- **Optimize Gradient Elution:** Modify the mobile phase gradient to increase the resolution between the analyte peak and the regions of ion suppression identified in the post-column infusion experiment.[\[2\]](#)
- **Change Stationary Phase:** If co-elution persists, consider a column with a different selectivity (e.g., C18, Phenyl-Hexyl, Cyano, HILIC).
- **Use a Divert Valve:** Program a divert valve to send the highly polar, early-eluting matrix components (like salts) and late-eluting hydrophobic components (like lipids) to waste, preventing them from entering the MS source.[\[11\]](#)

Strategy 2: Advanced Sample Preparation

The goal of sample preparation is to remove as many interfering matrix components as possible while efficiently recovering the analyte.[\[12\]](#)

- **Protein Precipitation (PPT):** A simple and fast method, but often insufficient for removing phospholipids, a major source of matrix effects.[\[13\]](#)
- **Liquid-Liquid Extraction (LLE):** Offers better cleanup than PPT by partitioning the analyte into an immiscible organic solvent, leaving polar interferences in the aqueous phase.[\[12\]](#) The selectivity can be tuned by adjusting the pH and solvent polarity.[\[12\]](#)
- **Solid-Phase Extraction (SPE):** A highly selective and effective technique for removing interferences.[\[1\]](#)[\[14\]](#) Mixed-mode SPE cartridges (e.g., combining reversed-phase and ion-exchange) can provide excellent cleanup for complex matrices.[\[13\]](#)
 - **Phospholipid Removal (PLR) SPE:** Specialized SPE sorbents are available that specifically target and remove phospholipids, which are notorious for causing ion

suppression.[15][16][17][18] These products often utilize a Lewis acid-base interaction to bind the phosphate head group of phospholipids.[15][16]

Protocol 3: Basic Solid-Phase Extraction (SPE) for Phospholipid Removal

Objective: To selectively extract a basic analyte from plasma while removing proteins and phospholipids.

Methodology (using a mixed-mode reversed-phase/strong cation-exchange sorbent):

- **Sample Pre-treatment:** Precipitate proteins by adding an equal volume of acidified acetonitrile (e.g., with 1% formic acid) to the plasma sample. Vortex and centrifuge.
- **Conditioning:** Condition the SPE cartridge with methanol, followed by an equilibration step with water.
- **Loading:** Load the supernatant from the protein precipitation step onto the conditioned SPE cartridge.
- **Washing:**
 - **Aqueous Wash:** Wash with an acidic aqueous solution (e.g., 2% formic acid in water) to remove polar interferences.
 - **Organic Wash:** Wash with an organic solvent (e.g., methanol) to remove non-polar interferences like phospholipids.
- **Elution:** Elute the basic analyte using a small volume of a strong base in an organic solvent (e.g., 5% ammonium hydroxide in methanol).
- **Final Step:** Evaporate the eluate to dryness and reconstitute in the initial mobile phase for LC-MS analysis.

Diagram: Decision Tree for Mitigating Matrix Effects

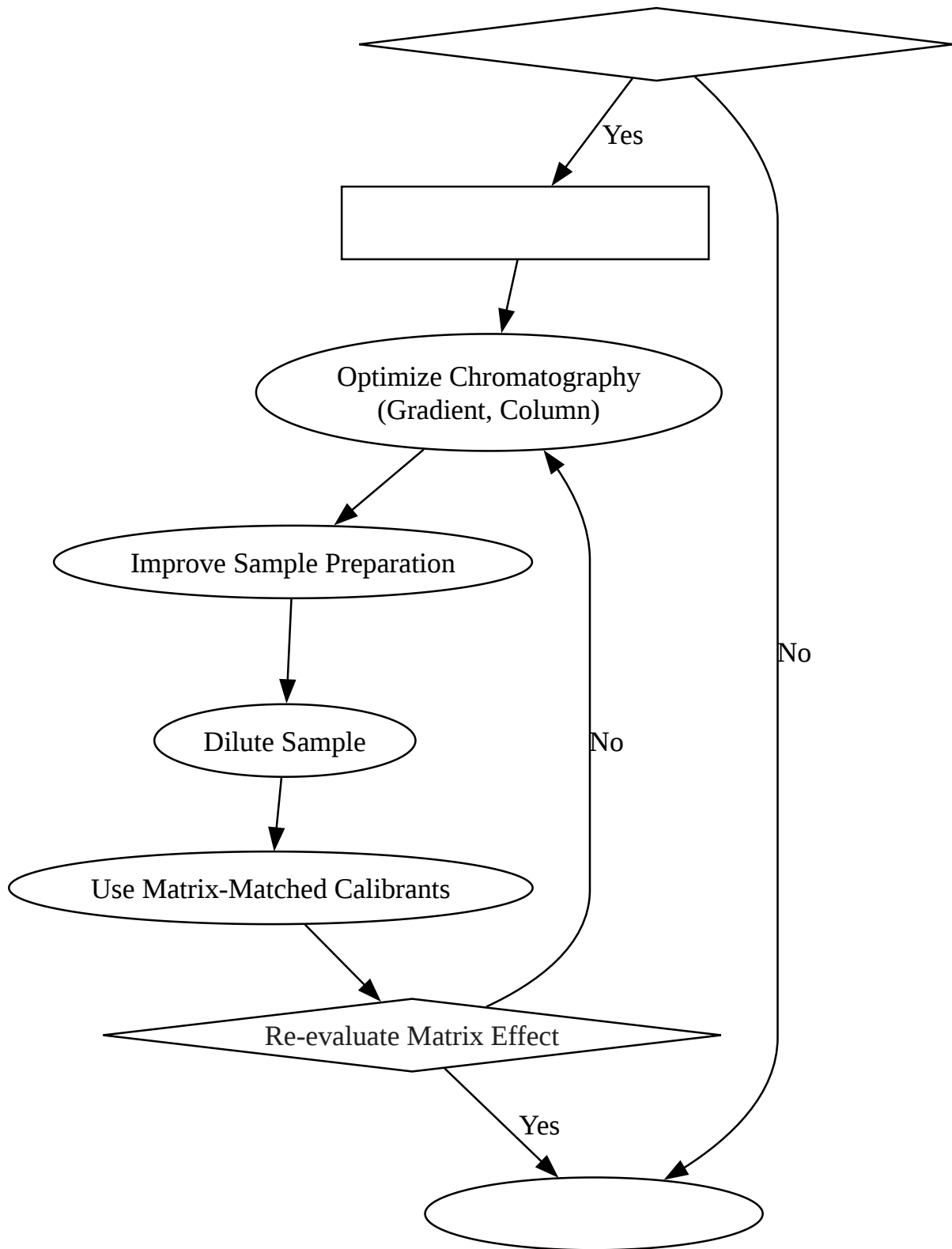

[Click to download full resolution via product page](#)

Need Custom Synthesis?

BenchChem offers custom synthesis for rare earth carbides and specific isotopic labeling.

Email: info@benchchem.com or [Request Quote Online](#).

Sources

- [1. longdom.org](http://1.longdom.org) [longdom.org]
- [2. welch-us.com](http://2.welch-us.com) [welch-us.com]
- [3. Matrix Effects: Causes and Solutions in Analysis | Phenomenex](https://3.Matrix%20Effects%3A%20Causes%20and%20Solutions%20in%20Analysis%20%7C%20Phenomenex) [phenomenex.com]
- [4. resolve-mass.ca](http://4.resolve-mass.ca) [resolve-mass.ca]
- [5. tandfonline.com](http://5.tandfonline.com) [tandfonline.com]
- [6. nebiolab.com](http://6.nebiolab.com) [nebiolab.com]
- [7. Assessment of matrix effect in quantitative LC-MS bioanalysis - PMC](https://7.Assessment%20of%20matrix%20effect%20in%20quantitative%20LC-MS%20bioanalysis%20-%20PMC) [pmc.ncbi.nlm.nih.gov]
- [8. pdf.benchchem.com](http://8.pdf.benchchem.com) [pdf.benchchem.com]
- [9. s3-eu-west-1.amazonaws.com](http://9.s3-eu-west-1.amazonaws.com) [s3-eu-west-1.amazonaws.com]
- [10. Biological Matrix Effects in Quantitative Tandem Mass Spectrometry-Based Analytical Methods: Advancing Biomonitoring - PMC](https://10.Biological%20Matrix%20Effects%20in%20Quantitative%20Tandem%20Mass%20Spectrometry-Based%20Analytical%20Methods%3A%20Advancing%20Biomonitoring%20-%20PMC) [pmc.ncbi.nlm.nih.gov]
- [11. Compensate for or Minimize Matrix Effects? Strategies for Overcoming Matrix Effects in Liquid Chromatography-Mass Spectrometry Technique: A Tutorial Review - PMC](https://11.Compensate%20for%20or%20Minimize%20Matrix%20Effects%3F%20Strategies%20for%20Overcoming%20Matrix%20Effects%20in%20Liquid%20Chromatography-Mass%20Spectrometry%20Technique%3A%20A%20Tutorial%20Review%20-%20PMC) [pmc.ncbi.nlm.nih.gov]
- [12. chromatographyonline.com](http://12.chromatographyonline.com) [chromatographyonline.com]
- [13. Development of Simple, Fast SPE Protocols for Basic Analyte Extraction with Phospholipid Removal Using Oasis PRiME MCX | Waters](https://13.Development%20of%20Simple%2C%20Fast%20SPE%20Protocols%20for%20Basic%20Analyte%20Extraction%20with%20Phospholipid%20Removal%20Using%20Oasis%20PRiME%20MCX%20%7C%20Waters) [waters.com]
- [14. chromatographyonline.com](http://14.chromatographyonline.com) [chromatographyonline.com]
- [15. sigmaaldrich.com](http://15.sigmaaldrich.com) [sigmaaldrich.com]
- [16. bioanalysis-zone.com](http://16.bioanalysis-zone.com) [bioanalysis-zone.com]
- [17. Phospholipid and Protein Removal in One Simple SPE Process Prevents Matrix-Based Signal Suppression](https://17.Phospholipid%20and%20Protein%20Removal%20in%20One%20Simple%20SPE%20Process%20Prevents%20Matrix-Based%20Signal%20Suppression) [discover.restek.com]
- [18. lcms.cz](http://18.lcms.cz) [lcms.cz]

- To cite this document: BenchChem. [Technical Support Center: Addressing Matrix Effects in LC-MS Analysis]. BenchChem, [2026]. [Online PDF]. Available at: [<https://www.benchchem.com/product/b3157686/docs#technical-support-center-addressing-matrix-effects-in-lc-ms-analysis>]

Disclaimer & Data Validity:

The information provided in this document is for Research Use Only (RUO) and is strictly not intended for diagnostic or therapeutic procedures. While BenchChem strives to provide accurate protocols, we make no warranties, express or implied, regarding the fitness of this product for every specific experimental setup.

Technical Support: The protocols provided are for reference purposes. Unsure if this reagent suits your experiment?

Need Industrial/Bulk Grade? [Request Custom Synthesis Quote](#)

BenchChem

Our mission is to be the trusted global source of essential and advanced chemicals, empowering scientists and researchers to drive progress in science and industry.

Contact

Address: 3281 E Guasti Rd
Ontario, CA 91761, United States
Phone: (601) 213-4426
Email: info@benchchem.com

[Contact our Ph.D. Support Team for a compatibility check](#)