

Technical Comparison Guide: Infrared Spectroscopy (IR) Fingerprints of Boc-Protected Imidazole Amino Acids

Author: BenchChem Technical Support Team. **Date:** April 2026

Compound of Interest

Compound Name:	<i>Boc-(R)-2-amino-3-(imidazol-1-yl)propanoic acid</i>
CAS No.:	760170-43-2
Cat. No.:	B3153523

[Get Quote](#)

Executive Summary

In peptide synthesis and drug development, the structural integrity of histidine derivatives is paramount due to the imidazole ring's susceptibility to racemization and side reactions. Boc-His(Boc)-OH (

-tert-butoxycarbonyl-

-tert-butoxycarbonyl-L-histidine) represents a critical reagent where the tert-butyloxycarbonyl (Boc) group protects both the

-amine and the imidazole nitrogen.[1]

This guide provides a technical analysis of the Infrared (IR) spectral fingerprints of Boc-protected histidine, objectively comparing it against the industry-standard alternative, Fmoc-His(Trt)-OH. By focusing on vibrational spectroscopy, we establish a non-destructive protocol for verifying protecting group coverage and distinguishing between common derivatives.

Mechanistic Basis: Vibrational Modes of the Boc-Imidazole System

To accurately interpret the IR spectrum of Boc-His(Boc)-OH, one must deconstruct the vibrational contributions of its three core components: the urethane (carbamate) backbone, the imidazole heterocycle, and the tert-butyl moieties.

The "Boc-on-Boc" Effect

Unlike mono-protected amino acids, Boc-His(Boc)-OH contains two distinct carbonyl environments.

- -Boc (Urethane): The carbonyl is part of a carbamate linkage.
- -Boc (Imidazole Carbamate): The carbonyl is directly attached to the aromatic imidazole nitrogen. This bond is more electron-deficient due to the electron-withdrawing nature of the imidazole ring, often causing a shift in the carbonyl stretching frequency () compared to the aliphatic urethane.

The Imidazole Ring Signature

The imidazole ring exhibits characteristic "breathing" modes and C=C/C=N stretching vibrations in the 1500–1600 cm^{-1} region. Protection of the imidazole nitrogen (specifically at the

or

position) perturbs these ring modes, suppressing the broad N-H stretching band typically seen in free histidine ($\sim 2800\text{--}3200 \text{ cm}^{-1}$) and altering the ring fingerprint region.

Comparative Analysis: Boc-His(Boc)-OH vs. Alternatives

The primary alternative for histidine incorporation in Solid Phase Peptide Synthesis (SPPS) is Fmoc-His(Trt)-OH. While Fmoc chemistry is standard for base-labile strategies, Boc chemistry offers superior suppression of racemization for histidine.[2]

Spectral Fingerprint Comparison

The following table contrasts the key IR diagnostic bands for Boc-protected histidine against Fmoc-protected and free histidine.

Table 1: Diagnostic IR Bands (cm⁻¹)

Vibrational Mode	Boc-His(Boc)-OH (Target)	Fmoc-His(Trt)-OH (Alternative)	Free L-Histidine (Reference)
Carbonyl ()	1690–1760 (Broad/Split) (Overlapping & carbamates)	1680–1720(Single Fmoc carbamate)	~1600 (COO ⁻ asym) (Zwitterionic form)
Gem-Dimethyl ()	1365 & 1390 (Strong Doublet)(Diagnostic for t-Butyl)	Absent	Absent
Aromatic Out-of-Plane ()	Weak/Absent in 700- 800 region	740 & 760 (Very Strong)(Diagnostic for Fmoc)	Weak Imidazole bands
Imidazole Ring ()	~1540–1600 (Sharp)	~1580–1600 (Trityl overlap)	~1560–1640
N-H Stretch ()	~3300–3400 (Amide only)	~3300–3400 (Amide only)	~2600–3100 (Broad, ammonium)

Performance Insight: Why Use Boc-His(Boc)?

While Fmoc is more common, IR verification of Boc-His(Boc)-OH is critical because this specific derivative is often chosen to solve racemization issues.

- **Racemization Control:** Experimental data indicates that Boc-His(Boc)-OH significantly reduces epimerization during coupling compared to Fmoc-His(Trt)-OH. For example,

coupling at 50°C yielded only 0.18% D-isomer for the Boc-derivative versus 6.8% for the Trt-derivative [1].[1][2]

- IR Validation: Therefore, confirming the presence of the N-imidazole Boc group via IR (checking for the intensity of the carbonyl band and the 1365/1390 doublet) is a proxy for ensuring the reagent's "anti-racemization" integrity.

Experimental Protocol: ATR-FTIR Validation System

This protocol utilizes Attenuated Total Reflectance (ATR) FTIR, which requires minimal sample preparation and allows for the recovery of the precious amino acid derivative.

Materials & Equipment

- Instrument: FTIR Spectrometer with Diamond or ZnSe ATR accessory.
- Resolution: 4 cm⁻¹.[\[3\]](#)
- Scans: 32–64 scans.
- Solvent (Cleaning): Isopropanol or Methanol (HPLC Grade).

Step-by-Step Workflow

- System Initialization:
 - Clean the ATR crystal with isopropanol and a lint-free wipe.
 - Collect a Background Spectrum (air) to subtract atmospheric water and CO₂.
- Sample Deposition:
 - Place approximately 2–5 mg of solid Boc-His(Boc)-OH powder directly onto the crystal center.
 - Apply pressure using the anvil to ensure intimate contact (monitor the "energy meter" if available).
- Data Acquisition:

- Acquire the sample spectrum.[\[3\]](#)[\[4\]](#)[\[5\]](#)[\[6\]](#)[\[7\]](#)[\[8\]](#)[\[9\]](#)[\[10\]](#)[\[11\]](#)[\[12\]](#)[\[13\]](#)
- Self-Validation Check: Ensure the strongest peak (Carbonyl region) has an absorbance between 0.1 and 1.0 A.U. If >1.5, reduce pressure or sample amount to avoid detector saturation.
- Spectral Processing:
 - Apply Baseline Correction (linear or polynomial).
 - Identify peak positions using the software's "Peak Pick" function.
- Cleaning:
 - Wipe the crystal immediately. Cross-contamination is the primary source of false "impurity" peaks.

Data Interpretation Logic (Decision Tree)

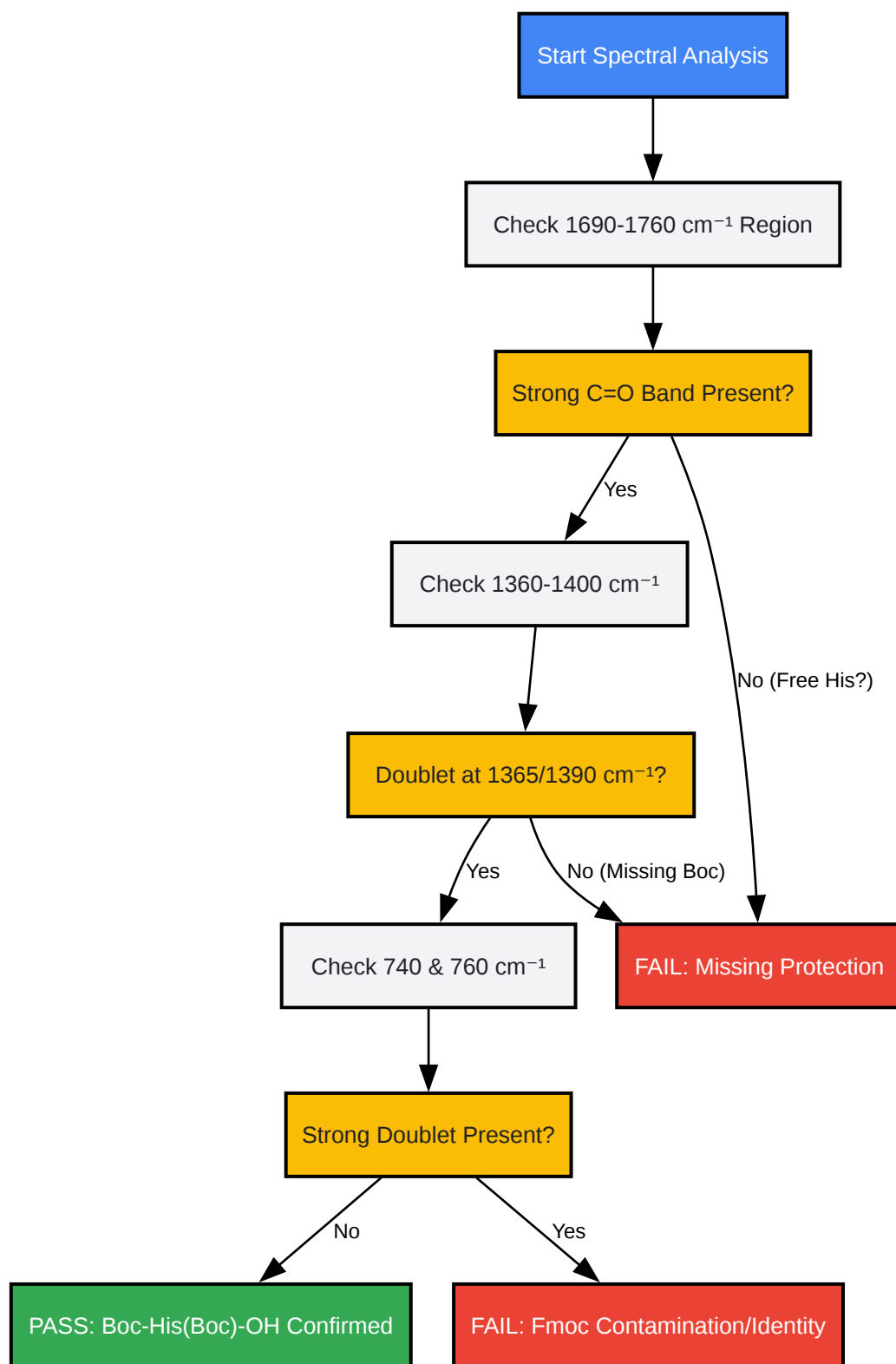

[Click to download full resolution via product page](#)

Figure 1: Logic flow for validating Boc-His(Boc)-OH identity via IR spectroscopy.

Visualizing the Molecular Fingerprint[10]

The following diagram illustrates the correlation between the chemical structure of Boc-His(Boc)-OH and its vibrational nodes.

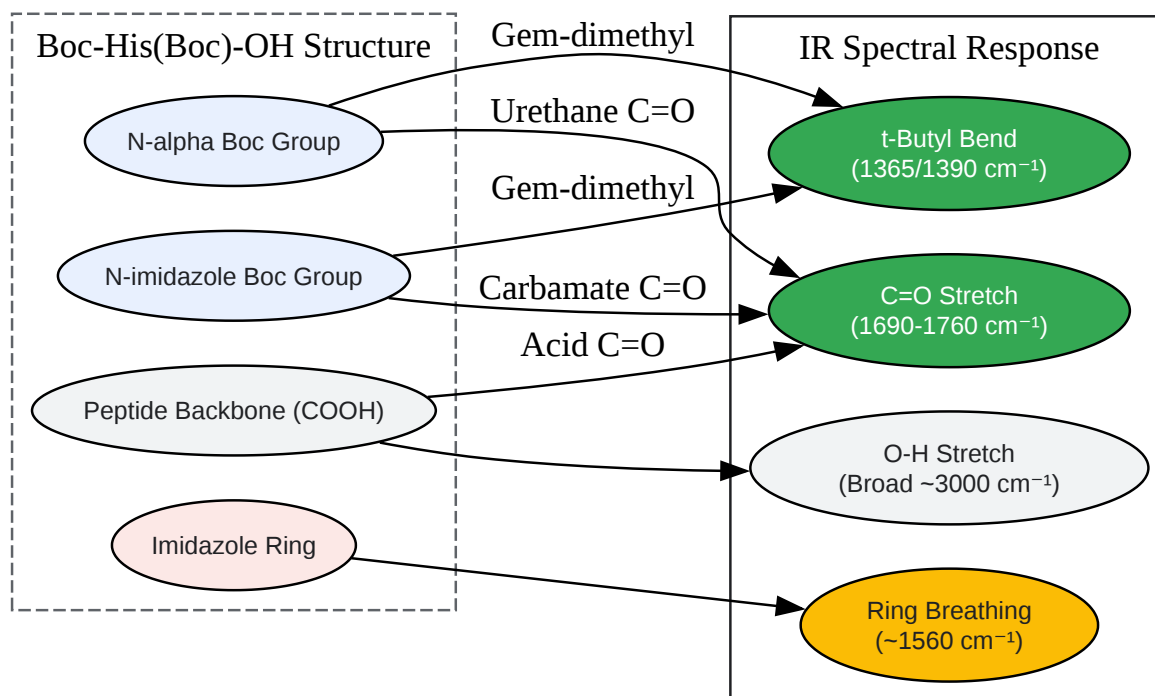

[Click to download full resolution via product page](#)

Figure 2: Mapping chemical moieties to specific IR vibrational bands.

References

- Csendes, Z., et al. (2010). Structural characterisation of silica gel anchored, biomimetic, mixed-ligand Co(II)-amino acid complexes. ResearchGate. Retrieved from [[Link](#)]
- Barth, A. (2000). Infrared Spectroscopy of Proteins. Biochimica et Biophysica Acta (BBA) - Bioenergetics.

Need Custom Synthesis?

BenchChem offers custom synthesis for rare earth carbides and specific isotopic labeling.

Email: info@benchchem.com or [Request Quote Online](#).

Sources

- [1. pdf.benchchem.com \[pdf.benchchem.com\]](https://pdf.benchchem.com)
- [2. pdf.benchchem.com \[pdf.benchchem.com\]](https://pdf.benchchem.com)
- [3. americanlaboratory.com \[americanlaboratory.com\]](https://americanlaboratory.com)
- [4. chem.libretexts.org \[chem.libretexts.org\]](https://chem.libretexts.org)
- [5. researchgate.net \[researchgate.net\]](https://researchgate.net)
- [6. undergradsciencejournals.okstate.edu \[undergradsciencejournals.okstate.edu\]](https://undergradsciencejournals.okstate.edu)
- [7. undergradsciencejournals.okstate.edu \[undergradsciencejournals.okstate.edu\]](https://undergradsciencejournals.okstate.edu)
- [8. Amino acid side chain contribution to protein FTIR spectra: impact on secondary structure evaluation - PMC \[pmc.ncbi.nlm.nih.gov\]](https://pubmed.ncbi.nlm.nih.gov)
- [9. pubs.acs.org \[pubs.acs.org\]](https://pubs.acs.org)
- [10. Fingerprint IR spectroscopy to probe amino acid conformations in the gas phase - PubMed \[pubmed.ncbi.nlm.nih.gov\]](https://pubmed.ncbi.nlm.nih.gov)
- [11. 2D IR Spectroscopy of Histidine: Probing Side-Chain Structure and Dynamics via Backbone Amide Vibrations - PMC \[pmc.ncbi.nlm.nih.gov\]](https://pubmed.ncbi.nlm.nih.gov)
- [12. dspace.library.uu.nl \[dspace.library.uu.nl\]](https://dspace.library.uu.nl)
- [13. researchgate.net \[researchgate.net\]](https://researchgate.net)
- To cite this document: BenchChem. [Technical Comparison Guide: Infrared Spectroscopy (IR) Fingerprints of Boc-Protected Imidazole Amino Acids]. BenchChem, [2026]. [Online PDF]. Available at: [<https://www.benchchem.com/product/b3153523/docs#technical-comparison-guide-infrared-spectroscopy-ir-fingerprints-of-boc-protected-imidazole-amino-acids>]

Disclaimer & Data Validity:

The information provided in this document is for Research Use Only (RUO) and is strictly not intended for diagnostic or therapeutic procedures. While BenchChem strives to provide accurate protocols, we make no warranties, express or implied, regarding the fitness of this product for every specific experimental setup.

Technical Support: The protocols provided are for reference purposes. Unsure if this reagent suits your experiment?

Need Industrial/Bulk Grade? [Request Custom Synthesis Quote](#)

BenchChem

Our mission is to be the trusted global source of essential and advanced chemicals, empowering scientists and researchers to drive progress in science and industry.

Contact

Address: 3281 E Guasti Rd
Ontario, CA 91761, United States
Phone: (601) 213-4426
Email: info@benchchem.com

[Contact our Ph.D. Support Team for a compatibility check](#)