

Application Note: Scale-Up Synthesis and Downstream Utilization of 2-Acetamidoacetyl Chloride

Author: BenchChem Technical Support Team. **Date:** April 2026

Compound of Interest

Compound Name: 2-Acetamidoacetyl chloride

CAS No.: 72952-59-1

Cat. No.: B3152175

[Get Quote](#)

Executive Summary

2-Acetamidoacetyl chloride (N-acetylglycyl chloride) is a highly reactive, versatile building block used extensively in peptide synthesis and active pharmaceutical ingredient (API) manufacturing. However, its scale-up is notoriously difficult due to extreme moisture sensitivity, thermal instability, and a high propensity for intramolecular degradation. This application note details optimized, self-validating protocols—comparing advanced batch operations with continuous-flow chemistry—to successfully scale the synthesis of **2-acetamidoacetyl chloride** while mitigating critical failure pathways.

Mechanistic Causality: The Azlactone Challenge

When synthesizing **2-acetamidoacetyl chloride** from N-acetylglycine, the primary mode of failure during scale-up is the intramolecular cyclization of the intermediate. The oxygen atom of the N-acetyl group acts as an internal nucleophile, attacking the highly reactive acyl chloride carbon to form an oxazolone (azlactone)[1].

Causality of Reagent Choice: Traditional methods utilizing thionyl chloride (

) often require elevated temperatures (reflux) to drive the reaction to completion.

Thermodynamically, this heat heavily favors the cyclization pathway, destroying the product[2].

Furthermore, the presence of tertiary amine bases during downstream coupling rapidly converts preformed acid chlorides into less reactive, epimerization-prone oxazolones[3].

To circumvent this, our protocol employs Oxalyl Chloride (

with catalytic N,N-Dimethylformamide (DMF) to generate a Vilsmeier-Haack intermediate. This allows the chlorination to proceed smoothly at 0–5 °C, kinetically trapping the **2-acetamidoacetyl chloride** and preventing oxazolone formation[4].

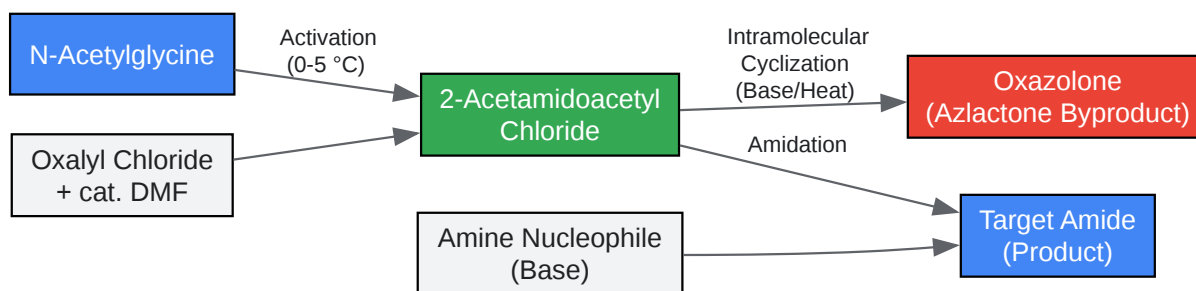

[Click to download full resolution via product page](#)

Reaction pathways of **2-Acetamidoacetyl chloride** highlighting the oxazolone side-reaction.

Process Optimization & Quantitative Data

Scaling up highly reactive intermediates requires strict control over residence times and heat transfer. Continuous-flow chemistry has revolutionized the handling of protected amino acid chlorides, which can degrade in seconds at room temperature[3].

Self-Validating Systems: The protocols below incorporate real-time Attenuated Total Reflectance Fourier Transform Infrared (ATR-FTIR) spectroscopy as an In-Process Control (IPC). The acid chloride exhibits a distinct carbonyl stretch at ~1800

, whereas the oxazolone byproduct appears at ~1830

. The reaction is deemed self-validating when the 1800

peak plateaus without the emergence of the 1830

peak.

Table 1: Comparison of Activation Parameters for N-Acetylglucine

Activation Method	Temp (°C)	Reaction Time	Yield of Acid Chloride (%)	Oxazolone Byproduct (%)	Scale-Up Suitability
Thionyl Chloride (Batch)	60–70	2–4 hours	45–55	30–40	Poor (High thermal degradation)
Oxalyl Chloride / DMF (Batch)	0–5	1 hour	85–90	< 5	Moderate (Exotherm control needed)
Oxalyl Chloride (Flow)	0	30 seconds	> 95	< 1	Excellent (High atom economy)

Experimental Protocols

Protocol A: Batch Scale-Up Synthesis of 2-Acetamidoacetyl Chloride (100 g Scale)

Objective: Isolate or utilize the acid chloride with minimal thermal degradation.

- Preparation: Equip a 2 L jacketed glass reactor with a mechanical stirrer, internal temperature probe, dropping funnel, and a nitrogen inlet connected to a scrubber system (to neutralize
- ,
- , and

off-gases).

- Charging: Charge the reactor with N-acetylglycine (100 g, 0.85 mol) and anhydrous Dichloromethane (DCM, 800 mL). Add N,N-Dimethylformamide (DMF, 3.3 mL, 0.05 eq) as a catalyst.
- Cooling: Circulate coolant to bring the internal temperature to 0–2 °C.
- Activation: Load Oxalyl chloride (118 g, 0.93 mol, 1.1 eq) into the dropping funnel. Add dropwise over 90 minutes.
 - Causality Check: The slow addition controls the endothermic/exothermic fluctuations and manages the vigorous evolution of

and

gases.
- In-Process Control (IPC): Stir for an additional 30 minutes at 5 °C. Draw a 0.5 mL aliquot and analyze via ATR-FTIR. The reaction is complete when the broad carboxylic acid O-H stretch (~2500-3000) disappears and a sharp acid chloride C=O stretch appears at ~1800 .
- Degassing: Apply a mild vacuum (400 mbar) for 15 minutes at 5 °C to remove dissolved and excess oxalyl chloride.
- Downstream Utilization: The resulting pale-yellow solution of **2-acetamidoacetyl chloride** must be used immediately in the next synthetic step (e.g., amidation) to prevent spontaneous degradation.

Protocol B: Continuous Flow Synthesis and Amidation (Self-Validating Workflow)

Objective: Generate the acid chloride in situ and immediately couple it with an amine nucleophile to completely bypass oxazolone formation[3].

- System Setup: Utilize a microreactor system with two PFA (perfluoroalkoxy) residence coils and two T-mixers.
- Reservoir Preparation:
 - Reservoir A: 1.0 M N-acetylglycine + 0.05 M DMF in anhydrous THF.
 - Reservoir B: 1.2 M Oxalyl chloride in anhydrous THF.
 - Reservoir C: 1.0 M Amine nucleophile + 2.5 M N,N-Diisopropylethylamine (DIPEA) in THF.
- Activation Stage: Pump Reservoir A and B at equal flow rates (e.g., 5 mL/min) into T-Mixer 1, maintained at 0 °C. The mixture enters Residence Coil 1 (Volume: 5 mL, Residence Time: 30 seconds).
 - Causality Check: 30 seconds is sufficient for Vilsmeier-mediated chlorination while being too brief for side-reactions to initiate.
- Coupling Stage: The effluent from Coil 1 meets Reservoir C (pumped at 10 mL/min) at T-Mixer 2. The combined stream enters Residence Coil 2 (Volume: 40 mL, Residence Time: 2 minutes) at 20 °C.
- Quenching & Isolation: The output stream is directed into a stirred vessel containing saturated aqueous

to quench any unreacted acid chloride and neutralize amine hydrochlorides. The organic layer is separated, dried, and concentrated to yield the target N-acetylglycyl amide.

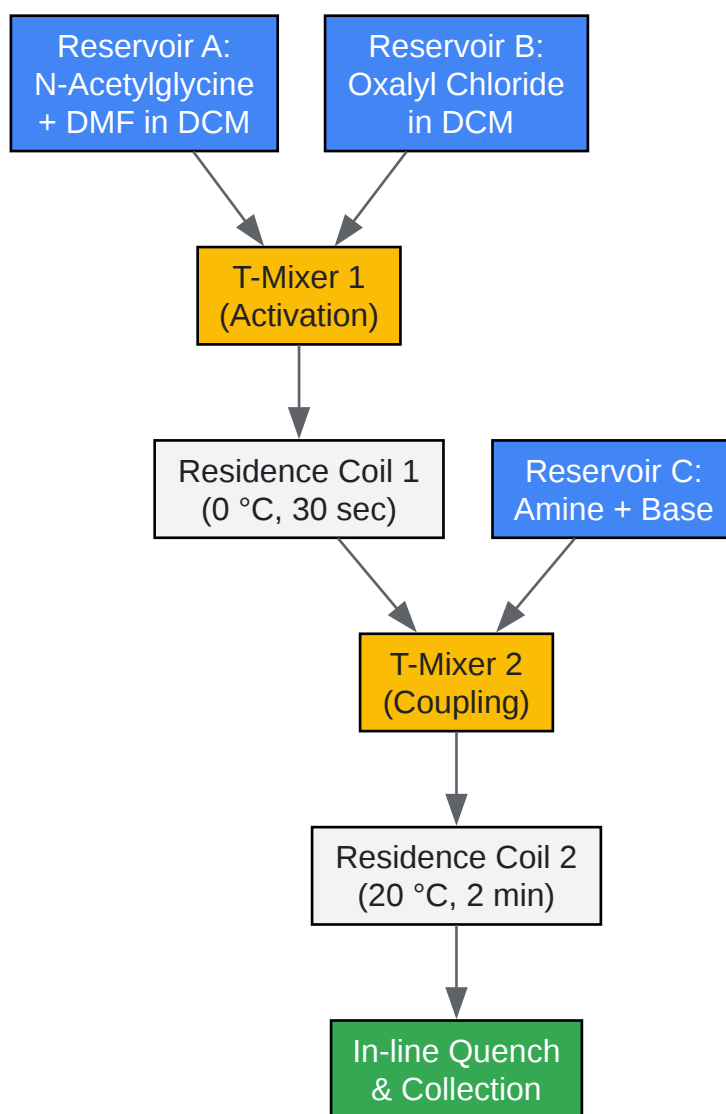

[Click to download full resolution via product page](#)

Continuous flow microreactor setup for the in situ generation and coupling of the acid chloride.

References

- Title: Peptide Synthesis via Amino Acid Halides Source: Accounts of Chemical Research URL:[[Link](#)]
- Title: Synthesis of Chiral Building Blocks for Use in Drug Discovery Source: MDPI URL:[[Link](#)]
- Title: One-pot Vilsmeier reagent-mediated multicomponent reaction: A direct synthesis of oxazolones and Erlenmeyer azlactones from carboxylic acids Source: Comptes Rendus de

l'Académie des Sciences URL:[[Link](#)]

Need Custom Synthesis?

BenchChem offers custom synthesis for rare earth carbides and specific isotopic labeling.

Email: info@benchchem.com or [Request Quote Online](#).

Sources

- 1. pubs.acs.org [pubs.acs.org]
- 2. mdpi.com [mdpi.com]
- 3. Thieme E-Books & E-Journals [thieme-connect.de]
- 4. One-pot Vilsmeier reagent-mediated multicomponent reaction: A direct synthesis of oxazolones and Erlenmeyer azlactones from carboxylic acids [comptes-rendus.academie-sciences.fr]
- To cite this document: BenchChem. [Application Note: Scale-Up Synthesis and Downstream Utilization of 2-Acetamidoacetyl Chloride]. BenchChem, [2026]. [Online PDF]. Available at: [<https://www.benchchem.com/product/b3152175/docs#application-note-scale-up-synthesis-and-downstream-utilization-of-2-acetamidoacetyl-chloride>]

Disclaimer & Data Validity:

The information provided in this document is for Research Use Only (RUO) and is strictly not intended for diagnostic or therapeutic procedures. While BenchChem strives to provide accurate protocols, we make no warranties, express or implied, regarding the fitness of this product for every specific experimental setup.

Technical Support: The protocols provided are for reference purposes. Unsure if this reagent suits your experiment?

Need Industrial/Bulk Grade? [Request Custom Synthesis Quote](#)

BenchChem

Our mission is to be the trusted global source of essential and advanced chemicals, empowering scientists and researchers to drive progress in science and industry.

Contact

Address: 3281 E Guasti Rd

Ontario, CA 91761, United States

Phone: (601) 213-4426

Email: info@benchchem.com

[Contact our Ph.D. Support Team for a compatibility check](#)