

Application of Nitrogen Dioxide in Nitration Reactions: Detailed Application Notes and Protocols

Author: BenchChem Technical Support Team. **Date:** April 2026

Compound of Interest

Compound Name: NO₂-SPP

Cat. No.: B3149021

[Get Quote](#)

For Researchers, Scientists, and Drug Development Professionals

Introduction

Nitration, the introduction of a nitro group (-NO₂) into an organic molecule, is a fundamental and widely utilized transformation in organic synthesis.[1][2] Nitroaromatic compounds are crucial intermediates in the production of a vast array of commercially important products, including pharmaceuticals, agrochemicals, dyes, and explosives.[3][4] While traditional nitration methods often employ harsh and hazardous reagents like mixed nitric and sulfuric acids, the use of nitrogen dioxide (NO₂) as a nitrating agent offers a potent alternative.[5][6] This document provides detailed application notes and protocols for the use of NO₂ in the nitration of various aromatic compounds, focusing on modern, safer, and more selective methodologies.

Nitrogen dioxide is a highly reactive and toxic gas, and its direct use requires stringent safety measures.[6] However, recent advancements have led to the development of innovative catalytic systems that utilize NO₂ in a more controlled and efficient manner. These methods often involve solid acid catalysts or the encapsulation of NO₂ within porous materials like metal-organic frameworks (MOFs), significantly enhancing safety and selectivity.[3][7]

Safety Precautions

Working with nitrogen dioxide requires strict adherence to safety protocols due to its high toxicity and corrosive nature.[6][8]

- Ventilation: All manipulations involving NO₂ must be performed in a well-ventilated fume hood.[8]
- Personal Protective Equipment (PPE): Wear appropriate PPE, including chemical-resistant gloves, safety goggles, and a lab coat. In case of potential exposure to high concentrations, a respirator with a specific cartridge for acid gases is necessary.[6]
- Emergency Preparedness: An emergency shower and eyewash station should be readily accessible.[9] Have a spill kit available for neutralizing and containing any accidental releases.[10]
- Incompatible Materials: Avoid contact of NO₂ with combustible materials, water, and reducing agents.[9]

Application Notes: Nitration of Aromatic Compounds

The application of NO₂ in nitration can be tailored to various classes of aromatic substrates. The reactivity of the aromatic ring and the desired regioselectivity will dictate the choice of catalyst and reaction conditions.

Nitration of Simple Aromatic Hydrocarbons

Simple aromatic hydrocarbons like benzene and its derivatives can be efficiently nitrated using NO₂ in the presence of solid acid catalysts. These methods offer a greener alternative to the traditional mixed-acid process by minimizing corrosive waste streams.

Key Advantages:

- High conversion and selectivity.[7]
- Catalyst reusability.[7]

- Milder reaction conditions compared to mixed acids.[7]

Nitration of Phenols

Phenols are highly activated aromatic compounds, and their nitration requires careful control to avoid over-reaction and oxidation. Using NO_2 with specific catalytic systems allows for selective mono-nitration.

Key Advantages:

- Good yields of mononitrated products.
- Control over ortho/para selectivity.
- Avoidance of harsh oxidizing conditions.

Nitration of Anilines

Direct nitration of anilines with mixed acids is often problematic due to the basicity of the amino group, which can lead to oxidation and the formation of undesired byproducts. A common strategy involves the protection of the amino group as an acetanilide before nitration, followed by deprotection.[11]

Key Advantages of the Protection-Nitration-Deprotection Strategy:

- Prevents oxidation of the amino group.
- Allows for controlled nitration of the aromatic ring.
- Yields the desired nitroaniline isomers.[11]

Quantitative Data Summary

The following tables summarize quantitative data from various studies on the nitration of aromatic compounds using NO_2 -based systems.

Table 1: Nitration of Benzene and Toluene with NO_2 and Solid Acid Catalysts

Substrate	Catalyst	Temperature (°C)	Time (h)	Conversion (%)	Selectivity to Mononitro Product (%)	Reference
Benzene	Amberlite FPC3500	0	9	99.9	99.1 (Nitrobenzene)	[7]
Toluene	Immobilized AlCl ₃ -SiO ₂	35	-	86.5	100 (Mononitrotoluene, p/o ratio = 0.91)	[12]

Table 2: Nitration of Phenol and Substituted Phenols

Substrate	Nitrating System	Temperature (°C)	Time	Yield (%)	Product(s)	Reference
Phenol	NO ₂ @Zr-bptc-N	Room Temp	0.5 h	>85	o-nitrophenol, p-nitrophenol (~1:1)	[6]
Phenol	NaNO ₂ / [Msim]Cl	Room Temp	-	89	o-nitrophenol (50%), p-nitrophenol (39%)	[10]

 Table 3: Nitration of Halobenzenes with NO₂ and Zeolite Catalysts

Substrate	Catalyst	Temperature (°C)	Time (h)	Conversion (%)	p/o Ratio	Reference
Chlorobenzene	Zeolite H β	-	-	High	High para-selectivity	[13]
Bromobenzene	Zeolite H β	-	-	High	High para-selectivity	[13]

Experimental Protocols

Protocol 1: Nitration of Benzene using NO₂ and an Acidic Ion Exchange Resin

This protocol is based on the work of Wang et al. (2020) and provides a green and efficient method for the synthesis of nitrobenzene.[7]

Materials:

- Benzene
- Nitrogen dioxide (NO₂) gas
- Amberlite FPC3500 acidic ion exchange resin
- Oxygen balloon
- Round-bottom flask
- Magnetic stirrer

Procedure:

- To a round-bottom flask, add benzene and the Amberlite FPC3500 resin (20% by mass of benzene).
- Cool the flask to 0 °C in an ice bath.

- Introduce NO₂ gas into the flask (molar ratio of benzene to NO₂ of 1:28).
- Attach an oxygen balloon to the flask.
- Stir the reaction mixture at 0 °C for 9 hours.
- Upon completion, filter the catalyst from the reaction mixture.
- The liquid product can be analyzed by gas chromatography (GC) to determine conversion and selectivity.

Protocol 2: Nitration of Phenol using NO₂ Captured in a Metal-Organic Framework (MOF)

This protocol, adapted from the work by Bai et al. (2022), demonstrates a novel and safe method for phenol nitration using pre-adsorbed NO₂.^[6]

Materials:

- Phenol
- Chloroform (CHCl₃)
- Zr-bptc MOF loaded with NO₂ (NO₂@Zr-bptc-N)
- Round-bottom flask
- Magnetic stirrer
- Centrifuge

Procedure:

- Prepare a solution of phenol (0.75 mmol) in chloroform (5.0 mL) in a 10 mL round-bottom flask and stir for 5 minutes.
- Add NO₂@Zr-bptc-N containing 0.51 mmol of NO₂ to the solution.

- Stir the mixture at room temperature. The reaction is typically complete within 30 minutes.
- After the reaction, centrifuge the mixture to separate the solid MOF.
- The supernatant containing the nitrophenol products can be collected and analyzed by techniques such as NMR spectroscopy.

Protocol 3: Synthesis of p-Nitroaniline via a Protection-Nitration-Deprotection Strategy

This is a classic multi-step synthesis adapted from standard organic chemistry laboratory procedures.[\[11\]](#)[\[14\]](#)

Step 1: Protection of Aniline (Acetylation)

- In an Erlenmeyer flask, dissolve aniline in water containing hydrochloric acid.
- Add acetic anhydride, followed immediately by a solution of sodium acetate.
- Stir the mixture, and the acetanilide product will precipitate.
- Collect the acetanilide by vacuum filtration and wash with cold water.

Step 2: Nitration of Acetanilide

- Carefully add the dried acetanilide to a cooled mixture of concentrated nitric acid and sulfuric acid.
- Maintain the temperature below 10 °C during the addition.
- After the addition is complete, allow the mixture to warm to room temperature and stir for a designated time.
- Pour the reaction mixture onto crushed ice to precipitate the p-nitroacetanilide.
- Collect the product by vacuum filtration and wash thoroughly with cold water.

Step 3: Deprotection (Hydrolysis)

- Heat the p-nitroacetanilide in a solution of aqueous sulfuric acid under reflux.
- After cooling, neutralize the solution with a base (e.g., sodium hydroxide) to precipitate the p-nitroaniline.
- Collect the p-nitroaniline by vacuum filtration, wash with water, and purify by recrystallization.

Visualizations

Reaction Mechanism: Electrophilic Aromatic Nitration

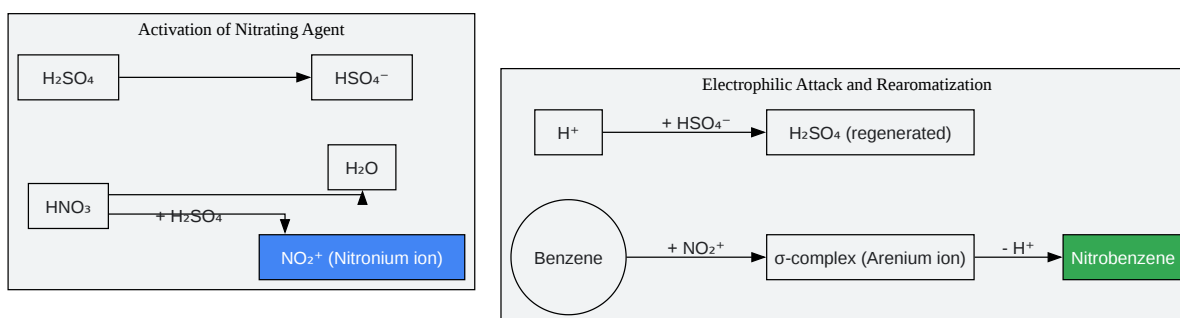

[Click to download full resolution via product page](#)

Caption: Mechanism of electrophilic aromatic nitration.

Experimental Workflow: Nitration using a Solid Catalyst

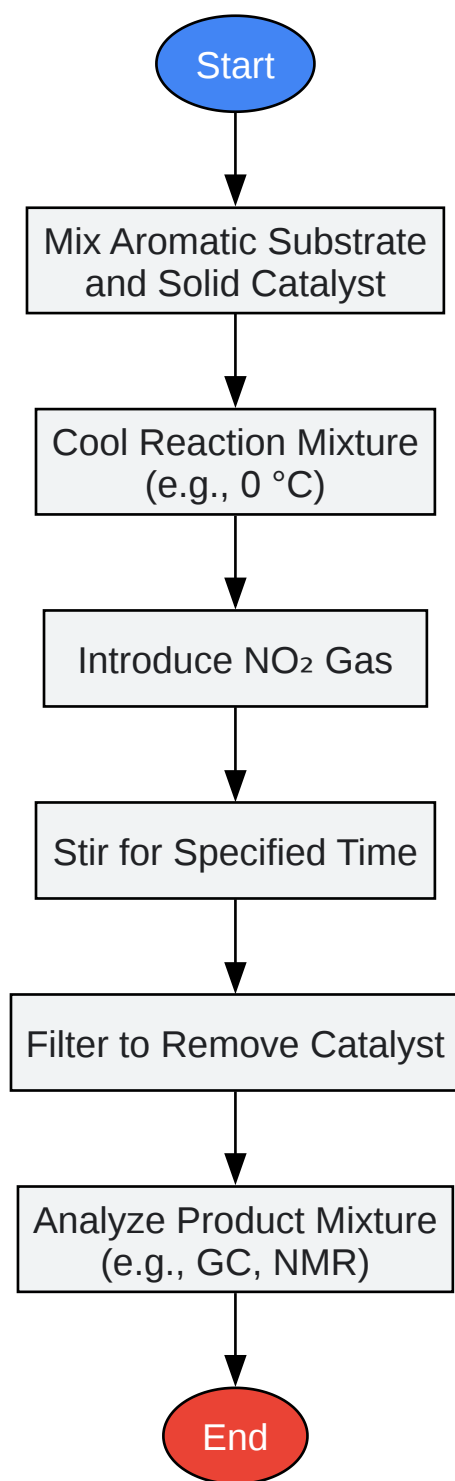

[Click to download full resolution via product page](#)

Caption: Workflow for nitration with a solid catalyst.

Logical Relationship: Protection-Nitration-Deprotection Strategy



[Click to download full resolution via product page](#)

Caption: Logic of the protection-nitration-deprotection sequence.

Need Custom Synthesis?

BenchChem offers custom synthesis for rare earth carbides and specific isotopic labeling.

Email: info@benchchem.com or [Request Quote Online](#).

References

- [1. pubs.acs.org \[pubs.acs.org\]](https://pubs.acs.org)
- [2. researchgate.net \[researchgate.net\]](https://researchgate.net)
- [3. masterorganicchemistry.com \[masterorganicchemistry.com\]](https://masterorganicchemistry.com)
- [4. researchgate.net \[researchgate.net\]](https://researchgate.net)
- [5. researchgate.net \[researchgate.net\]](https://researchgate.net)
- [6. pubs.acs.org \[pubs.acs.org\]](https://pubs.acs.org)
- [7. researchgate.net \[researchgate.net\]](https://researchgate.net)
- [8. Selective Nitration of Aromatic Compounds with Bismuth Subnitrate and Thionyl Chloride - PMC \[pmc.ncbi.nlm.nih.gov\]](https://pubmed.ncbi.nlm.nih.gov)
- [9. researchgate.net \[researchgate.net\]](https://researchgate.net)
- [10. scintiairanica.sharif.edu \[scintiairanica.sharif.edu\]](https://scintiairanica.sharif.edu)
- [11. scribd.com \[scribd.com\]](https://scribd.com)
- [12. researchgate.net \[researchgate.net\]](https://researchgate.net)
- [13. researchgate.net \[researchgate.net\]](https://researchgate.net)

- [14. studylib.net \[studylib.net\]](#)
- To cite this document: BenchChem. [Application of Nitrogen Dioxide in Nitration Reactions: Detailed Application Notes and Protocols]. BenchChem, [2026]. [Online PDF]. Available at: [<https://www.benchchem.com/product/b3149021/docs#application-of-nitrogen-dioxide-in-nitration-reactions-detailed-application-notes-and-protocols>]

Disclaimer & Data Validity:

The information provided in this document is for Research Use Only (RUO) and is strictly not intended for diagnostic or therapeutic procedures. While BenchChem strives to provide accurate protocols, we make no warranties, express or implied, regarding the fitness of this product for every specific experimental setup.

Technical Support: The protocols provided are for reference purposes. Unsure if this reagent suits your experiment?

Need Industrial/Bulk Grade? [Request Custom Synthesis Quote](#)

BenchChem

Our mission is to be the trusted global source of essential and advanced chemicals, empowering scientists and researchers to drive progress in science and industry.

Contact

Address: 3281 E Guasti Rd
Ontario, CA 91761, United States
Phone: (601) 213-4426
Email: info@benchchem.com

[Contact our Ph.D. Support Team for a compatibility check](#)