

Application Note: Scalable Manufacturing of 7-Isopropyl-1H-Indole

Author: BenchChem Technical Support Team. **Date:** February 2026

Compound of Interest

Compound Name: 7-isopropyl-1H-indole

CAS No.: 57817-04-6

Cat. No.: B3145654

[Get Quote](#)

Executive Summary

The synthesis of **7-isopropyl-1H-indole** (CAS: 115764-83-7) presents a specific regiochemical challenge. Classical methods like the Fischer Indole Synthesis often suffer from poor regioselectivity or require unstable hydrazine intermediates when targeting the 7-position. This Application Note details the Bartoli Indole Synthesis as the preferred route for scale-up. This one-step conversion from 2-isopropyl nitrobenzene utilizes vinylmagnesium bromide to achieve high regiofidelity.

This guide addresses the critical engineering controls required to manage the highly exothermic nature of the Bartoli reaction, the handling of pyrophoric Grignard reagents, and the specific workup protocols necessary to break stable magnesium emulsions—a common bottleneck in large-scale production.

Reaction Engineering & Mechanism Route Selection Justification

| Parameter | Bartoli Route (Selected) | Fischer Route (Alternative) |
|-------------------|--|---|
| Starting Material | 2-Isopropylnitrobenzene (Commodity) | 2-Isopropylphenylhydrazine (Unstable/Custom) |
| Step Count | 1 Step (Nitro Indole) | 3 Steps (Nitro Aniline Hydrazine Indole) |
| Regioselectivity | Exclusive 7-position (driven by ortho-bulk) | Variable (Mixture of 7- and 5- isomers possible) |
| Thermal Risk | High (Cryogenic control required) | Moderate (High temp reflux required) |
| Atom Economy | Low (Requires 3-4 eq. Grignard) | High |

Mechanistic Pathway

The Bartoli synthesis relies on the reaction of the nitroarene with 3 equivalents of vinyl Grignard.^{[1][2]}

- Addition 1 & 2: Two equivalents of vinylmagnesium bromide attack the nitro group to form a nitroso intermediate, then an N,O-divinylhydroxylamine species.
- [3,3]-Sigmatropic Rearrangement: The steric bulk of the ortho-isopropyl group forces the rearrangement to the carbon ring, breaking the N-O bond and forming the C-C bond at the 2-position of the indole ring.
- Cyclization & Elimination: The third equivalent acts as a base to facilitate cyclization and aromatization.

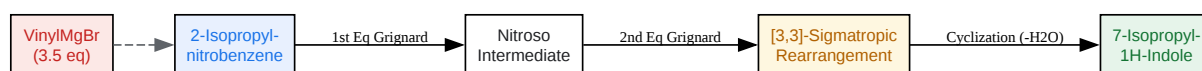

[Click to download full resolution via product page](#)

Figure 1: Mechanistic flow of the Bartoli Indole Synthesis highlighting the critical stoichiometry.

Process Safety Assessment

Critical Hazard: The reaction is extremely exothermic and involves large quantities of pyrophoric Grignard reagent.

- Heat of Reaction (): Estimated at -280 kJ/mol.
- Adiabatic Temperature Rise: Without active cooling, the reaction mass can exceed the boiling point of THF, leading to thermal runaway.
- Gas Evolution: None during the main reaction, but quenching releases significant heat and potential hydrogen gas if unreacted Mg is present.

Detailed Scale-Up Protocol

Scale: 1.0 kg Input (2-IsopropylNitrobenzene) Target Yield: 45–55% isolated (Standard for Bartoli due to steric bulk)

Reagents & Materials

- Substrate: 2-IsopropylNitrobenzene (1.0 kg, 6.05 mol)
- Reagent: Vinylmagnesium bromide (1.0 M in THF, 24.2 L, 4.0 eq). Note: Excess is required to drive full conversion.
- Solvent: Anhydrous THF (10 L, for dilution).
- Quench: Ammonium Chloride (sat. aq.) or 1M HCl (carefully controlled).

Step-by-Step Procedure

Phase 1: Reactor Setup & Cooling

- Inertion: Purge a 50 L glass-lined reactor (GLR) with

three times. Ensure moisture content

ppm.

- Charging: Charge Vinylmagnesium bromide (24.2 L) into the reactor.
- Cooling: Cool the Grignard solution to -45°C .
 - Process Tip: Do not cool below -50°C as viscosity increases, hindering mixing. Do not exceed -35°C to prevent side reactions (polymerization of vinyl Grignard).

Phase 2: Controlled Addition (The Critical Step)

- Preparation: Dilute 2-isopropylnitrobenzene (1.0 kg) in Anhydrous THF (5 L) in a separate dosing vessel.
- Dosing: Add the nitroarene solution to the Grignard reagent over 2 to 4 hours.
 - Control Parameter: Maintain internal temperature between -40°C and -30°C . Stop addition immediately if
 - Observation: Solution will turn dark brown/red.
- Post-Stir: After addition is complete, stir at -40°C for 1 hour, then allow to warm slowly to 0°C over 2 hours.
 - IPC (In-Process Control): HPLC should show $<2\%$ starting material.

Phase 3: Inverse Quench & Workup

Safety Note: Direct water addition to the reaction mass causes violent boiling. Use Inverse Quench.

- Quench Prep: In a second reactor (100 L), prepare a solution of saturated (20 L) and water (20 L) cooled to 5°C .
- Transfer: Slowly transfer the cold reaction mixture into the aqueous quench solution.

- Rate: Control transfer to keep quench tank
- Emulsion Breaking: The Bartoli reaction produces magnesium salts that form gelatinous emulsions.
 - Action: If emulsion persists, add Celite (0.5 kg) and filter through a pad, OR adjust pH to ~4 with dilute
to solubilize Mg salts (verify product stability at acidic pH first).
- Extraction: Separate phases. Extract aqueous layer with Ethyl Acetate (L).[3]
- Drying: Combine organics, wash with brine, dry over
, and concentrate.

Phase 4: Purification

- Crude Isolation: You will obtain a dark oil.
- Distillation (Preferred for Scale): Perform high-vacuum fractional distillation.
 - Boiling Point: 7-isopropylindole boils at approx. 130–135°C at 0.5 mmHg.
- Crystallization (Alternative): If solid, recrystallize from Hexane/Toluene (9:1).

Analytical Specifications & Troubleshooting Quality Control Table

| Test | Specification | Method |
|---------------|-----------------------------------|---------------------|
| Appearance | Off-white to pale brown solid/oil | Visual |
| Assay | > 98.0% | HPLC (C18, ACN/H2O) |
| 1H NMR | Confirms 7-isopropyl doublet | 400 MHz DMSO-d6 |
| Water Content | < 0.5% | Karl Fischer |

Troubleshooting Guide

- Low Yield (<30%):
 - Cause: Temperature rose above -30°C during addition.[\[4\]](#)[\[5\]](#)
 - Fix: Improve jacket cooling or slow down dosing rate.
 - Cause: Moisture in THF.
 - Fix: Karl Fischer test on all solvents; ensure <100 ppm water.
- Regioisomers Detected:
 - Cause: Starting material contamination (e.g., 4-isopropyl isomer).
 - Fix: Verify purity of 2-isopropyl nitrobenzene input.

Process Flow Diagram (PFD)

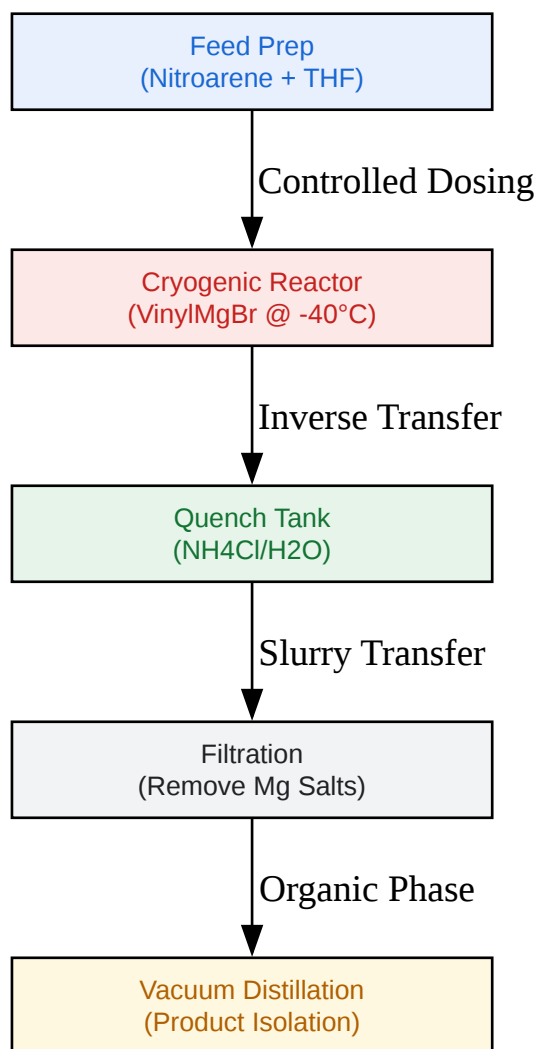

[Click to download full resolution via product page](#)

Figure 2: Unit operation flow for the batch production of 7-isopropylindole.

References

- Bartoli, G., et al. (1989).[6] "The Reaction of Vinyl Grignard Reagents with 2-Substituted Nitroarenes: A New Approach to the Synthesis of 7-Substituted Indoles." *Tetrahedron Letters*, 30(16), 2129–2132.[6] [Link](#)
- Dobbs, A. P., et al. (1999). "Total Synthesis of Indoles from Trichloronitrobenzene." *Synlett*, 10, 1594–1596.
- Beclabuvir Process Patents:Patent WO2011102806A1. (Describes analogous indole intermediate synthesis steps). [Link](#)

- Popowycz, F., et al. (2014). "Applications of Bartoli Indole Synthesis." Current Organic Chemistry, 18(19).

Need Custom Synthesis?

BenchChem offers custom synthesis for rare earth carbides and specific isotopic labeling.

Email: info@benchchem.com or [Request Quote Online](#).

Sources

- [1. Bartoli indole synthesis - Wikipedia \[en.wikipedia.org\]](#)
- [2. pdf.benchchem.com \[pdf.benchchem.com\]](#)
- [3. WO2011102806A1 - Process for preparing entecavir and its intermediates - Google Patents \[patents.google.com\]](#)
- [4. ricerca.uniba.it \[ricerca.uniba.it\]](#)
- [5. WO2022018625A1 - Process for the preparation of an intermediate used in the synthesis of letermovir - Google Patents \[patents.google.com\]](#)
- [6. jk-sci.com \[jk-sci.com\]](#)
- To cite this document: BenchChem. [Application Note: Scalable Manufacturing of 7-Isopropyl-1H-Indole]. BenchChem, [2026]. [Online PDF]. Available at: [\[https://www.benchchem.com/product/b3145654#scale-up-procedure-for-7-isopropyl-1h-indole-production\]](https://www.benchchem.com/product/b3145654#scale-up-procedure-for-7-isopropyl-1h-indole-production)

Disclaimer & Data Validity:

The information provided in this document is for Research Use Only (RUO) and is strictly not intended for diagnostic or therapeutic procedures. While BenchChem strives to provide accurate protocols, we make no warranties, express or implied, regarding the fitness of this product for every specific experimental setup.

Technical Support: The protocols provided are for reference purposes. Unsure if this reagent suits your experiment? [[Contact our Ph.D. Support Team for a compatibility check](#)]

Need Industrial/Bulk Grade? [Request Custom Synthesis Quote](#)

BenchChem

Our mission is to be the trusted global source of essential and advanced chemicals, empowering scientists and researchers to drive progress in science and industry.

Contact

Address: 3281 E Guasti Rd
Ontario, CA 91761, United States
Phone: (601) 213-4426
Email: info@benchchem.com