

Application Note: Enzymatic Resolution of Methyl 2-(hydroxymethyl)butanoate

Author: BenchChem Technical Support Team. **Date:** April 2026

Compound of Interest

Compound Name:	Methyl 2-(hydroxymethyl)butanoate
CAS No.:	56970-75-3
Cat. No.:	B3145276

[Get Quote](#)

Executive Summary

Methyl 2-(hydroxymethyl)butanoate (also known as Methyl 2-ethyl-3-hydroxypropionate) possesses a primary hydroxyl group and a chiral center at the

-position. Traditional chemical resolution of such primary alcohols is challenging due to the distance of the chiral center from the reaction site. This guide details a high-efficiency Lipase-Catalyzed Kinetic Resolution (KR) via irreversible transesterification.

By utilizing *Pseudomonas cepacia* lipase (PCL) or *Candida antarctica* Lipase B (CAL-B) in an organic solvent with a vinyl ester acyl donor, researchers can achieve high enantiomeric excess (

) and theoretical yields close to 50% for both the unreacted alcohol and the acylated product.

Scientific Principles & Mechanism[1]

The Challenge of -Chiral Primary Alcohols

Unlike secondary alcohols where the lipase interacts directly with the chiral center, primary alcohols like **Methyl 2-(hydroxymethyl)butanoate** require the enzyme to discriminate based on the spatial difference between the

-substituents (Ethyl vs. Carbomethoxy).

- Steric Discrimination: The lipase binding pocket must distinguish between the medium-sized ethyl group and the planar, polar ester group.
- Chemoselectivity: The reaction must exclusively acylate the free hydroxyl group without hydrolyzing the methyl ester or causing transesterification of the methyl ester moiety.

Kinetic Resolution Mechanism

The process relies on the difference in reaction rates (

vs

) between the two enantiomers.

- Acyl Donor: Vinyl acetate or Vinyl butanoate is used. The tautomerization of the leaving group (vinyl alcohol acetaldehyde) renders the reaction irreversible, driving it to completion.
- Enantiomeric Ratio (E): The efficiency is quantified by the E-value.^[1] An is required for practical resolution.

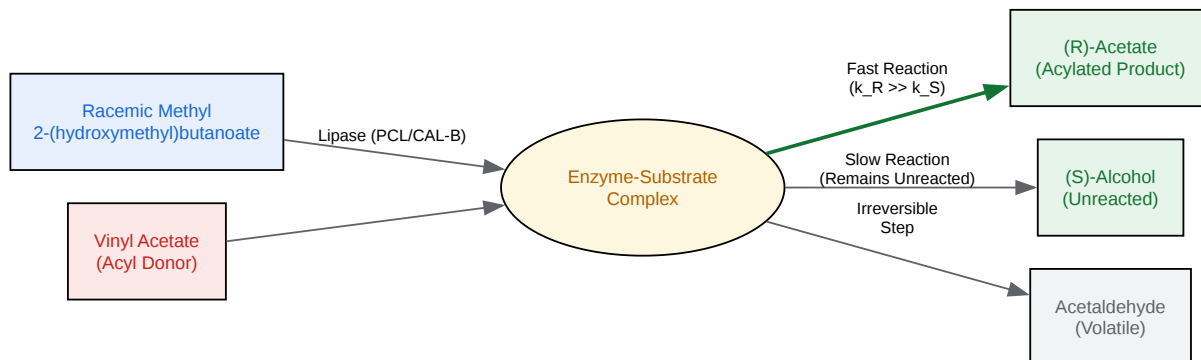

[Click to download full resolution via product page](#)

Figure 1: Mechanism of Lipase-Catalyzed Kinetic Resolution via Irreversible Transesterification.

Materials & Equipment

Reagents

Component	Specification	Role
Substrate	Methyl 2-(hydroxymethyl)butanoate (Racemic)	Target Molecule
Enzyme A	Lipase PS Amano IM (Burkholderia cepacia)	Primary Catalyst Candidate
Enzyme B	Novozym 435 (Candida antarctica Lipase B)	Secondary Catalyst Candidate
Acyl Donor	Vinyl Acetate or Vinyl Butanoate	Irreversible Acylating Agent
Solvent	Diisopropyl Ether (DIPE) or MTBE	Reaction Medium (Hydrophobic)
Molecular Sieves	4Å, Activated	Water Scavenger

Equipment

- Thermostatted orbital shaker (set to 30–40°C).
- GC-FID or HPLC with Chiral Column (e.g., Chiralcel OD-H or Chirasil-DEX CB).
- Rotary Evaporator.

Experimental Protocol

Phase 1: Enzyme Screening (Analytical Scale)

Objective: Determine which lipase provides the highest E-value.

- Preparation: In a 4 mL glass vial, dissolve 20 mg of racemic **Methyl 2-(hydroxymethyl)butanoate** in 1 mL of anhydrous DIPE.
- Activation: Add 2 equivalents (eq.) of Vinyl Acetate.
- Initiation: Add 10 mg of enzyme (Screen: Amano PS, Novozym 435, Amano AK).
- Incubation: Shake at 30°C, 200 rpm.
- Sampling: At t=1h, 4h, and 24h, withdraw 50 µL. Filter through a micro-filter to remove enzyme.
- Analysis: Analyze via Chiral GC. Calculate conversion () and enantiomeric excess (,).
 - Expert Insight: PCL (Amano PS) typically favors the acylation of the (R)-enantiomer for this class of primary alcohols, leaving the (S)-alcohol enriched.

Phase 2: Scale-Up Protocol (Gram Scale)

Objective: Produce isolated enantiomers with >98% ee.

Step 1: Reaction Setup

- Weigh 5.0 g (approx. 34 mmol) of racemic **Methyl 2-(hydroxymethyl)butanoate**.
- Dissolve in 100 mL of anhydrous DIPE (0.34 M concentration).
 - Note: High dilution is not necessary; 0.3–0.5 M is optimal for throughput.
- Add 3.0 g of activated 4Å Molecular Sieves (powdered) to ensure anhydrous conditions.
 - Causality: Water traces can lead to competitive hydrolysis of the methyl ester or the acyl donor.
- Add 6.3 mL (2.0 eq) of Vinyl Acetate.
- Equilibrate the mixture at 35°C for 20 minutes.

Step 2: Biocatalysis

- Add 1.0 g of Immobilized Lipase PS (Amano) (20% w/w relative to substrate).
- Stir at 200 rpm. Do not stir magnetically if using fragile immobilized beads; use an overhead stirrer or orbital shaker to prevent pulverization of the support.
- Monitoring: Monitor reaction progress by GC every 2 hours.
 - Target: Stop reaction when conversion reaches 49-50%. Do not exceed 50% to preserve the optical purity of the remaining substrate.

Step 3: Termination & Work-up

- Filtration: Filter the reaction mixture through a sintered glass funnel to remove the enzyme and molecular sieves.
- Washing: Wash the enzyme cake with 2 x 20 mL DIPE.
- Concentration: Combine filtrates and concentrate under reduced pressure (rotary evaporator, 40°C, 200 mbar) to remove solvent and excess vinyl acetate/acetaldehyde.

Step 4: Purification

- Column Chromatography: The residue contains the (S)-alcohol and the (R)-acetate.
 - Stationary Phase: Silica Gel 60.
 - Eluent: Hexane:Ethyl Acetate gradient (start 90:10 70:30).
 - Separation: The acetate (less polar) will elute first; the alcohol (more polar) will elute second.
- Hydrolysis (Optional): To recover the (R)-alcohol from the (R)-acetate, treat the acetate with catalytic K₂CO₃ in Methanol (Zemplén deacetylation) at 0°C to avoid racemization.

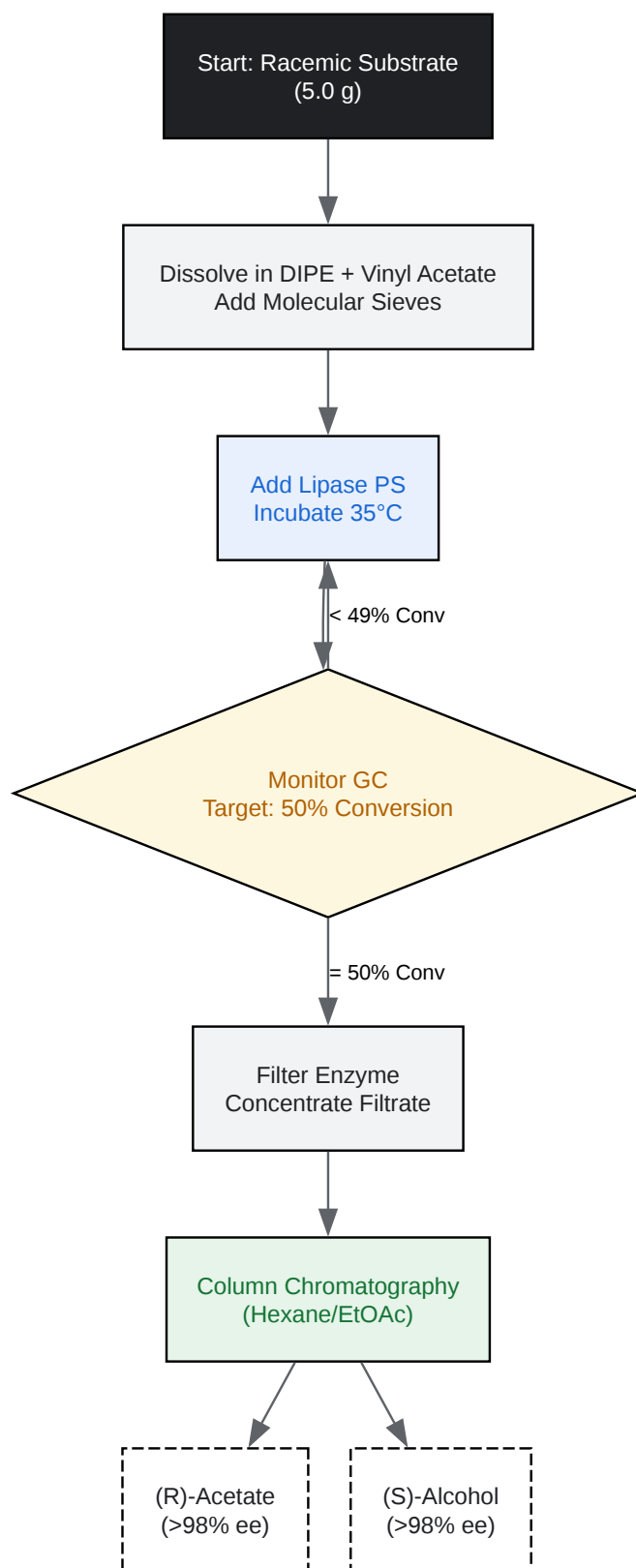

[Click to download full resolution via product page](#)

Figure 2: Operational Workflow for Gram-Scale Resolution.

Analytical Methods (Self-Validation)

To ensure the protocol is working, you must validate the Enantiomeric Excess (ee) and Conversion (c).

Calculation of E-value

Use the equation by Chen et al. to determine the selectivity factor (E):

- Success Criteria:

is excellent. If

, re-screen solvents (try Toluene or Hexane).

Chromatographic Conditions

- Instrument: GC with FID detector.
- Column: Chirasil-DEX CB (25 m x 0.25 mm x 0.25 μ m) or equivalent cyclodextrin-based column.
- Carrier Gas: Helium (1.0 mL/min).
- Temperature Program: 80°C (hold 2 min)
5°C/min
160°C.
- Retention Times (Approximate):
 - (S)-Alcohol: 12.5 min
 - (R)-Alcohol: 13.2 min
 - (R)-Acetate: 15.8 min
 - (S)-Acetate: 16.5 min

- Note: Acetylated products generally elute later on non-polar phases but order may invert on chiral phases. Inject pure racemic standards to confirm.

Troubleshooting & Optimization

Issue	Probable Cause	Corrective Action
Low Reaction Rate	Enzyme water content too low/high.	Equilibrate enzyme at defined humidity (0.5) or add molecular sieves if too wet.
Low E-value	Non-specific background reaction.	Ensure no chemical catalysis occurs (neutral pH, no Lewis acids). Try lowering temperature to 20°C.
Hydrolysis of Methyl Ester	Water in system.	Strictly use anhydrous solvents and activated molecular sieves.
Incomplete Separation	Column overload.	Use a flash cartridge with a high length-to-diameter ratio.

References

- Ghanem, A. (2007). Trends in Lipase-Catalyzed Asymmetric Access to Enantiomerically Pure/Enriched Chiral Building Blocks. *Tetrahedron*. [Link](#)
- Kazlauskas, R. J., et al. (1991). A Rule to Predict Which Enantiomer of a Secondary Alcohol Reacts Faster in Reactions Catalyzed by Cholesterol Esterase, Lipase from *Pseudomonas cepacia*, and Lipase from *Candida rugosa*. *Journal of Organic Chemistry*. [Link](#)
- Breuer, M., et al. (2004). Industrial Methods for the Production of Optically Active Intermediates. *Angewandte Chemie International Edition*. [Link](#)
- Akai, S., et al. (2004). Lipase-Catalyzed Kinetic Resolution of 2-Substituted-1-Alkanols. *Organic & Biomolecular Chemistry*. [Link](#)

Need Custom Synthesis?

BenchChem offers custom synthesis for rare earth carbides and specific isotopic labeling.

Email: info@benchchem.com or [Request Quote Online](#).

Sources

- [1. Organic Syntheses Procedure \[orgsyn.org\]](#)
- To cite this document: BenchChem. [Application Note: Enzymatic Resolution of Methyl 2-(hydroxymethyl)butanoate]. BenchChem, [2026]. [Online PDF]. Available at: [\[https://www.benchchem.com/product/b3145276/docs#application-note-enzymatic-resolution-of-methyl-2-hydroxymethyl-butanoate\]](https://www.benchchem.com/product/b3145276/docs#application-note-enzymatic-resolution-of-methyl-2-hydroxymethyl-butanoate)

Disclaimer & Data Validity:

The information provided in this document is for Research Use Only (RUO) and is strictly not intended for diagnostic or therapeutic procedures. While BenchChem strives to provide accurate protocols, we make no warranties, express or implied, regarding the fitness of this product for every specific experimental setup.

Technical Support: The protocols provided are for reference purposes. Unsure if this reagent suits your experiment?

Need Industrial/Bulk Grade? [Request Custom Synthesis Quote](#)

BenchChem

Our mission is to be the trusted global source of essential and advanced chemicals, empowering scientists and researchers to drive progress in science and industry.

Contact

Address: 3281 E Guasti Rd

Ontario, CA 91761, United States

Phone: (601) 213-4426

Email: info@benchchem.com

Contact our Ph.D. Support Team for a compatibility check