

Technical Support Center: Resolving NMR Signal Overlap in Ethyl-Substituted Piperazines

Author: BenchChem Technical Support Team. **Date:** April 2026

Compound of Interest

Compound Name: *1-[1-(4-Propan-2-ylphenyl)ethyl]piperazine*

CAS No.: *517855-37-7*

Cat. No.: *B3143082*

[Get Quote](#)

Welcome to the technical support center for researchers, scientists, and drug development professionals. This guide is designed to provide in-depth troubleshooting strategies and practical solutions for a common challenge in NMR spectroscopy: resolving signal overlap in ethyl-substituted piperazines. The complex conformational dynamics and subtle electronic effects within these molecules often lead to crowded and ambiguous spectra. Here, we will explore the underlying causes of these issues and provide a range of techniques, from simple adjustments to advanced multidimensional experiments, to help you obtain clear, interpretable data.

Frequently Asked Questions (FAQs)

Q1: Why are the signals for the ethyl group and the piperazine ring protons overlapping in my ¹H NMR spectrum?

A1: Signal overlap in ethyl-substituted piperazines is a frequent observation arising from several factors. The chemical shifts of the piperazine ring protons and the methylene protons of the ethyl group often fall within a similar range (typically 2.5-3.5 ppm). Furthermore, piperazine

derivatives can exist as multiple conformers due to restricted rotation around the C-N amide bond (if acylated) and ring inversion of the piperazine chair conformation.[1][2][3] This can lead to a doubling of signals, further complicating the spectrum.[1][4]

Q2: I see more signals than expected for the piperazine ring protons. What could be the cause?

A2: The presence of more than the expected two signals for an unsymmetrically substituted piperazine is often due to slow conformational exchange on the NMR timescale.[1][4] This can be caused by:

- **Restricted Amide Bond Rotation:** If the piperazine is N-acylated, the partial double bond character of the amide C-N bond can lead to the presence of distinct rotamers (rotational conformers).[1][2]
- **Slow Ring Inversion:** The piperazine ring can undergo chair-to-chair interconversion. If this process is slow at the analysis temperature, separate signals for axial and equatorial protons may be observed.[2][3]

These phenomena can result in four or more distinct signals for the piperazine NCH₂ groups.[1][4]

Q3: How can I confirm that the overlapping signals belong to the ethyl group?

A3: The characteristic splitting pattern of an ethyl group is a triplet for the methyl (CH₃) protons and a quartet for the methylene (CH₂) protons.[5][6][7] If the quartet is obscured by piperazine signals, you can use a 2D COSY (Correlation Spectroscopy) experiment to confirm the coupling between the triplet and the overlapping quartet.[8][9] A cross-peak between the methyl triplet and the methylene quartet will definitively identify the ethyl group spin system.[8]

Troubleshooting Guides: Step-by-Step Protocols

Guide 1: Modifying Experimental Conditions

When faced with signal overlap, simple adjustments to the experimental parameters can often provide a solution without resorting to more complex NMR techniques.

The chemical shifts of protons are sensitive to the solvent environment.^[10] Changing the solvent can induce differential shifts in the overlapping signals, potentially resolving them.

Protocol: Solvent Study

- **Sample Preparation:** Prepare separate, equally concentrated samples of your ethyl-substituted piperazine in a range of deuterated solvents with varying polarities and aromaticity (e.g., CDCl₃, DMSO-d₆, Acetone-d₆, Benzene-d₆).
- **Data Acquisition:** Acquire a standard 1D ¹H NMR spectrum for each sample under identical temperature and spectrometer conditions.
- **Analysis:** Compare the spectra to identify a solvent system that provides the best resolution of the ethyl group and piperazine ring signals. Aromatic solvents like Benzene-d₆ can induce significant shifts due to anisotropy effects.

Table 1: Effect of Solvent on Chemical Shifts

Solvent	Polarity	Aromaticity	Expected Effect on Chemical Shifts
CDCl ₃	Low	No	Standard reference
DMSO-d ₆	High	No	Can disrupt intermolecular hydrogen bonding, altering chemical shifts
Acetone-d ₆	Medium	No	Intermediate effects
Benzene-d ₆	Low	Yes	Can cause significant upfield or downfield shifts due to anisotropic effects

As discussed, the conformational dynamics of piperazines are often temperature-dependent.^[1]^[2] By altering the temperature, you can influence the rate of exchange between conformers,

which can either simplify or further resolve the spectrum.

Protocol: Variable Temperature (VT) NMR

- Initial Spectrum: Acquire a ¹H NMR spectrum at room temperature.
- Heating: Gradually increase the temperature of the NMR probe (e.g., in 10-15 °C increments). At higher temperatures, the rate of conformational exchange may increase, leading to the coalescence of multiple signals into fewer, sharper peaks.^{[1][2]}
- Cooling: If heating does not resolve the overlap, gradually decrease the temperature. Lower temperatures can slow the exchange rate, potentially sharpening the signals of individual conformers.
- Data Analysis: Analyze the spectra at each temperature to identify the optimal condition for signal resolution.

Guide 2: Advanced NMR Techniques

If modifying the experimental conditions is insufficient, more advanced 1D and 2D NMR experiments can provide the necessary resolution and structural information.

A COSY experiment is invaluable for identifying coupled protons. It will show correlations between the CH₃ and CH₂ protons of the ethyl group, even if the CH₂ signal is overlapped.^[8]

Experimental Workflow: COSY

Caption: Workflow for a COSY experiment.

Protocol: Acquiring a COSY Spectrum

- Setup: Load your sample and acquire a standard 1D ¹H spectrum to determine the spectral width.
- Pulse Program: Select a standard COSY pulse sequence (e.g., cosygp).
- Acquisition: Set the appropriate spectral widths in both dimensions and acquire the 2D data.

- Processing and Analysis: Process the data using a sine-bell or similar window function. Look for off-diagonal cross-peaks that connect the triplet of the ethyl's methyl group to the overlapped methylene quartet.

When proton signals are severely overlapped, dispersing them into a second dimension based on the chemical shifts of the attached carbons can provide excellent resolution.

- HSQC (Heteronuclear Single Quantum Coherence): This experiment correlates protons directly to the carbons they are attached to (one-bond C-H correlation).[11][12] This is useful for assigning the carbon signals of the ethyl group and piperazine ring.
- HMBC (Heteronuclear Multiple Bond Correlation): This experiment shows correlations between protons and carbons that are two or three bonds away.[11][12] This can be used to confirm the connectivity of the ethyl group to the piperazine ring.

Logical Relationship of 2D NMR Techniques

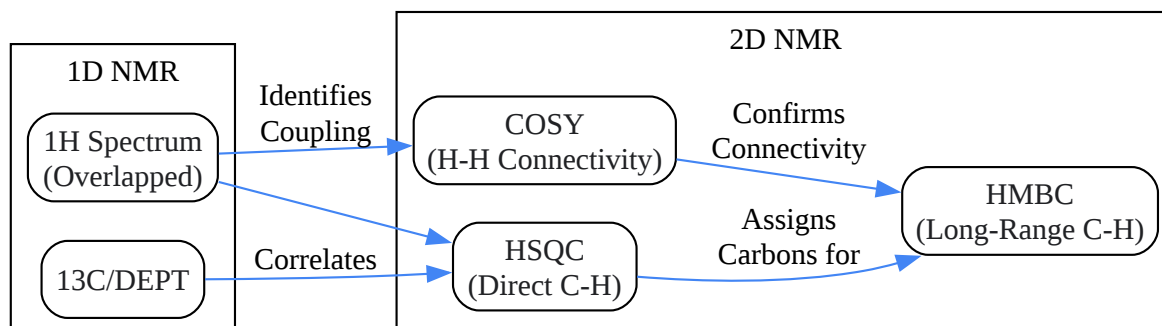

[Click to download full resolution via product page](#)

Caption: Interplay of 2D NMR for structural elucidation.

Protocol: Acquiring HSQC and HMBC Spectra

- 1D Spectra: Acquire high-quality 1D proton and carbon (with DEPT) spectra to determine chemical shift ranges and set spectral widths.

- **HSQC Acquisition:** Use a sensitivity-enhanced HSQC pulse sequence. This will clearly show which protons are attached to which carbons, allowing you to distinguish the ethyl CH₂ and piperazine CH₂ signals based on their carbon chemical shifts.[\[12\]](#)
- **HMBC Acquisition:** Set up the HMBC experiment with a long-range coupling delay optimized for ~8 Hz. This will reveal correlations from the ethyl protons to the piperazine ring carbons, and vice-versa, confirming the overall structure.[\[12\]](#)

For molecules with a Lewis basic site, such as the nitrogen atoms in piperazine, lanthanide shift reagents can be used to induce large changes in the chemical shifts of nearby protons. [\[13\]](#)[\[14\]](#) The magnitude of the shift is dependent on the distance of the proton from the lanthanide ion, which can effectively spread out a crowded spectrum.[\[13\]](#)[\[15\]](#)

Protocol: Using Lanthanide Shift Reagents

- **Initial Spectrum:** Acquire a ¹H NMR spectrum of your compound in an anhydrous solvent (e.g., CDCl₃).
- **Incremental Addition:** Add a small, known amount of a lanthanide shift reagent (e.g., Eu(fod)₃ or Pr(fod)₃) to the NMR tube.
- **Acquire Spectra:** Acquire a spectrum after each addition. The protons closest to the piperazine nitrogens will experience the largest shifts.
- **Analysis:** Monitor the spectra to see if the induced shifts resolve the signal overlap. Be aware that LSRs can cause line broadening.[\[14\]](#)

Table 2: Common Lanthanide Shift Reagents

Reagent	Lanthanide Ion	Direction of Shift
Eu(fod) ₃	Europium (Eu)	Downfield
Pr(fod) ₃	Praseodymium (Pr)	Upfield

Conclusion

Resolving signal overlap in the NMR spectra of ethyl-substituted piperazines requires a systematic approach. By understanding the underlying causes of this overlap, namely conformational dynamics and coincidental chemical shifts, researchers can employ a variety of techniques to obtain clear and unambiguous data. Starting with simple modifications to experimental conditions like solvent and temperature can often provide a quick solution. For more persistent issues, advanced 2D NMR techniques such as COSY, HSQC, and HMBC offer powerful tools for complete structural elucidation.

References

- Common ¹H NMR Splitting Patterns. (n.d.).
- Wodtke, R., et al. (2016). Synthesis, dynamic NMR characterization and XRD studies of novel N,N'-substituted piperazines for bioorthogonal labeling. *Beilstein Journal of Organic Chemistry*, 12, 2480-2492. Available from: [[Link](#)]
- Wodtke, R., et al. (2018). NMR-based investigations of acyl-functionalized piperazines concerning their conformational behavior in solution. *RSC Advances*, 8(72), 41335-41348. Available from: [[Link](#)]
- Aguilar, J. A., et al. (2010). Pure shift ¹H NMR: a resolution of the resolution problem? *Angewandte Chemie International Edition*, 49(23), 3901-3903. Available from: [[Link](#)]
- Advanced NMR Techniques and Applications. (n.d.). Fiveable.
- Wodtke, R., et al. (2018). NMR-based investigations of acyl-functionalized piperazines concerning their conformational behavior in solution. *RSC Advances*. Available from: [[Link](#)]
- Xiao, Z., et al. (2005). Complete assignments of ¹H and ¹³C NMR data for ten phenylpiperazine derivatives. *Magnetic Resonance in Chemistry*, 43(9), 758-762. Available from: [[Link](#)]
- Optical purity determination by NMR: use of chiral lanthanide shift reagents and a base line technique. (1987). *Journal of Pharmaceutical and Biomedical Analysis*, 5(5), 459-467. Available from: [[Link](#)]
- ¹H NMR: Spin-Splitting Patterns Explained: Definition, Examples, Practice & Video Lessons. (n.d.).

- Lanthanide shift reagents in nmr. (n.d.). SlideShare. Retrieved from [\[Link\]](#)
- Chen, C. Y., et al. (2020). Application of Lanthanide Shift Reagent to the ¹H-NMR Assignments of Acridone Alkaloids. *Molecules*, 25(22), 5429. Available from: [\[Link\]](#)
- ¹H VT-NMR spectroscopy of piperazine 2c (400 MHz, d₈-THF) showing 5.40–3.10 ppm. (n.d.). ResearchGate. Retrieved from [\[Link\]](#)
- Lanthanide Shift Reagents in ¹³C Nuclear Magnetic Resonance: Quantitative Determination of Pseudocontact Shifts and Assignment o. (1974). *Canadian Journal of Chemistry*, 52(21), 3624-3632. Available from: [\[Link\]](#)
- Common HNMR Patterns. (n.d.). Organic Chemistry Tutor. Retrieved from [\[Link\]](#)
- (PDF) Synthesis, dynamic NMR characterization and XRD studies of novel N,N'-substituted piperazines for bioorthogonal labeling. (2016). ResearchGate. Retrieved from [\[Link\]](#)
- Effect of solvent change on chemical shifts of 4-benzyl-4-hydroxypiperidines. (2017). *International Journal of Chemical and Pharmaceutical Sciences*, 8(2), 1-5. Available from: [\[Link\]](#)
- 14. Splitting pattern of the ¹H NMR spectrum peaks of an ethyl group... (n.d.). ResearchGate. Retrieved from [\[Link\]](#)
- Advanced NMR techniques for structural characterization of heterocyclic structures. (n.d.). ESA-IPB. Retrieved from [\[Link\]](#)
- Influence of solvents on the ¹H-NMR chemical shifts of 4-(4-acetyl-5-methyl-1H-1,2,3. (2020). *Egyptian Journal of Chemistry*, 63(10), 3747-3756. Available from: [\[Link\]](#)
- H-NMR Familiar Groups that are Easy to Recognize. (n.d.).
- Steinberg, J., et al. (2018). Synthesis, Dynamic NMR Characterization, and XRD Study of 2,4-Difluorobenzoyl-Substituted Piperazines. *Molecules*, 23(10), 2533. Available from: [\[Link\]](#)
- qNMR of mixtures: what is the best solution to signal overlap? (2014). Mestrelab Research. Retrieved from [\[Link\]](#)

- Wodtke, R., et al. (2016). Synthesis, dynamic NMR characterization and XRD studies of novel N,N'-substituted piperazines for bioorthogonal labeling. *Beilstein Journal of Organic Chemistry*. Available from: [[Link](#)]
- Understanding 2D NMR Spectra: How to Read and Interpret Them. (2025). Creative Biostructure. Retrieved from [[Link](#)]
- Inverse 2D Heteronuclear Correlation Experiments. (2010).
- Appleby, L. F., et al. (2020). Benchtop NMR analysis of piperazine-based drugs hyperpolarised by SABRE. *Magnetic Resonance in Chemistry*, 58(12), 1151-1159. Available from: [[Link](#)]
- Getting the Most Out of HSQC and HMBC Spectra. (n.d.). OUCI. Retrieved from [[Link](#)]
- HSQC and HMBC. (n.d.). Columbia University NMR Core Facility. Retrieved from [[Link](#)]
- Ch13 - 2D NMR. (n.d.). University of Calgary Chemistry. Retrieved from [[Link](#)]
- 5.1: COSY Spectra. (2022). Chemistry LibreTexts. Retrieved from [[Link](#)]
- Improving the resolution of quantitative NMR. (2024). University of Manchester Research Explorer. Retrieved from [[Link](#)]
- Two-dimensional a COSY and b NOESY NMR spectra of ethyl 2,2 -... (n.d.). ResearchGate. Retrieved from [[Link](#)]
- Interpretation of 2D NMR Spectra. (n.d.).
- 1-Ethyl-4-(hex-2-yl)piperazine - Optional[¹³C NMR] - Chemical Shifts - SpectraBase. (n.d.). Retrieved from [[Link](#)]
- New bis-piperazine derivatives: synthesis, characterization (IR, NMR), gamma-ray absorption, antimicrobial activity, molecular docking and dynamics study. (2023). *RSC Advances*, 13(45), 31693-31710. Available from: [[Link](#)]
- DESIGN AND SYNTHESIS OF SOME PIPERAZINE HYBRID MOLECULES. (2018). *Revue Roumaine de Chimie*, 63(5-6), 481-490. Available from: [[Link](#)]

- New bis-piperazine derivatives: synthesis, characterization (IR, NMR), gamma-ray absorption, antimicrobial activity, molecular docking and dynamics study. (2023). Turkish Journal of Chemistry. Available from: [\[Link\]](#)

Need Custom Synthesis?

BenchChem offers custom synthesis for rare earth carbides and specific isotopic labeling.

Email: info@benchchem.com or [Request Quote Online](#).

Sources

- 1. Synthesis, dynamic NMR characterization and XRD studies of novel N,N'-substituted piperazines for bioorthogonal labeling - PMC [[pmc.ncbi.nlm.nih.gov](https://pubmed.ncbi.nlm.nih.gov/)]
- 2. NMR-based investigations of acyl-functionalized piperazines concerning their conformational behavior in solution - RSC Advances (RSC Publishing) DOI:10.1039/C8RA09152H [pubs.rsc.org]
- 3. NMR-based investigations of acyl-functionalized piperazines concerning their conformational behavior in solution - RSC Advances (RSC Publishing) [pubs.rsc.org]
- 4. beilstein-journals.org [beilstein-journals.org]
- 5. askthenerd.com [askthenerd.com]
- 6. organicchemistrytutor.com [organicchemistrytutor.com]
- 7. web.mnstate.edu [web.mnstate.edu]
- 8. creative-biostructure.com [creative-biostructure.com]
- 9. chem.libretexts.org [chem.libretexts.org]
- 10. unn.edu.ng [unn.edu.ng]
- 11. fiveable.me [fiveable.me]
- 12. nmr.chem.columbia.edu [nmr.chem.columbia.edu]
- 13. Lanthanide shift reagents in nmr | PPTX [slideshare.net]
- 14. pdf.benchchem.com [pdf.benchchem.com]
- 15. mdpi.com [mdpi.com]
- To cite this document: BenchChem. [Technical Support Center: Resolving NMR Signal Overlap in Ethyl-Substituted Piperazines]. BenchChem, [2026]. [Online PDF]. Available at:

[<https://www.benchchem.com/product/b3143082/docs#technical-support-center-resolving-nmr-signal-overlap-in-ethyl-substituted-piperazines>]

Disclaimer & Data Validity:

The information provided in this document is for Research Use Only (RUO) and is strictly not intended for diagnostic or therapeutic procedures. While BenchChem strives to provide accurate protocols, we make no warranties, express or implied, regarding the fitness of this product for every specific experimental setup.

Technical Support: The protocols provided are for reference purposes. Unsure if this reagent suits your experiment?

Need Industrial/Bulk Grade? [Request Custom Synthesis Quote](#)

BenchChem

Our mission is to be the trusted global source of essential and advanced chemicals, empowering scientists and researchers to drive progress in science and industry.

Contact

Address: 3281 E Guasti Rd
Ontario, CA 91761, United States
Phone: (601) 213-4426
Email: info@benchchem.com

[Contact our Ph.D. Support Team for a compatibility check](#)