

# Application Notes and Protocols for FRET-Based Assays Using NBD-Labeled Sphingolipids

**Author:** BenchChem Technical Support Team. **Date:** April 2026

## Compound of Interest

Compound Name: C12-NBD Sphinganine

Cat. No.: B569086

[Get Quote](#)

For Researchers, Scientists, and Drug Development Professionals

## Introduction

Förster Resonance Energy Transfer (FRET) is a powerful, non-destructive technique for monitoring enzymatic activities and molecular interactions in real-time. When applied to the study of sphingolipid metabolism, FRET-based assays using NBD (Nitrobenzoxadiazole)-labeled sphingolipids offer a sensitive and quantitative method to investigate the activity of key enzymes involved in sphingolipid signaling pathways. These pathways are critical in numerous cellular processes, including proliferation, apoptosis, and inflammation, and their dysregulation is implicated in various diseases such as cancer and neurodegenerative disorders.

This document provides detailed application notes and experimental protocols for utilizing NBD-labeled sphingolipids in FRET-based assays to study enzymes central to sphingolipid metabolism, including acid sphingomyelinase (aSMase), glucosylceramide synthase (GCS), and ceramide kinase (CERK).

## Principle of the Assay

The core principle of these assays lies in the change in FRET efficiency upon enzymatic modification of a doubly-labeled sphingolipid substrate. Typically, an NBD fluorophore serves as one part of the FRET pair. When the NBD-labeled sphingolipid is metabolized by a specific enzyme, the distance between the FRET donor and acceptor changes, leading to a measurable change in the fluorescence emission spectrum. This change, often a ratiometric signal, allows for the quantification of enzyme activity. In simpler, non-FRET but fluorescence-based assays, the conversion of an NBD-labeled substrate to its product can be quantified by separating the lipids using High-Performance Liquid Chromatography (HPLC) and measuring the fluorescence of the product.

## Applications in Research and Drug Development

- **Enzyme Activity Profiling:** Directly measure the activity of key enzymes in the sphingolipid pathway, such as sphingomyelinases, ceramidases, and glucosylceramide synthases.
- **High-Throughput Screening (HTS):** Screen compound libraries for potential inhibitors or activators of sphingolipid-metabolizing enzymes, accelerating drug discovery efforts.
- **Inhibitor Characterization:** Determine the potency and mechanism of action of novel drug candidates by quantifying their effect on enzyme activity, often by determining IC50 values.
- **Cell-Based Assays:** Investigate sphingolipid metabolism directly within living cells, providing insights into metabolic flux and the effects of cellular signaling on enzyme activity.
- **Disease Research:** Study the role of sphingolipid dysregulation in various diseases and evaluate the efficacy of therapeutic interventions.

## Quantitative Data Summary

The following tables summarize quantitative data obtained from studies utilizing NBD-labeled sphingolipids to assess the activity and inhibition of key enzymes in sphingolipid metabolism.

Table 1: Inhibition of Golgi-Resident Sphingolipid Metabolizing Enzymes in MCF7 Cells.

Compound	Target Enzyme	IC50 (μM)	Assay System	NBD-Labeled Substrate
PDMP	Glucosylceramide Synthase (GCS)	~10	In situ (MCF7 cells)	NBD C6-Ceramide
PDMP	Ceramide Kinase (CERK)	~15	In situ (MCF7 cells)	NBD C6-Ceramide
Fenretinide (4HPR)	Ceramide Kinase (CERK)	~5	In situ (MCF7 cells)	NBD C6-Ceramide
NVP-231	Ceramide Kinase (CERK)	~0.5	In situ (MCF7 cells)	NBD C6-Ceramide
HPA-12	Sphingomyelin Synthase (SMS)	~0.02	In situ (MCF7 cells)	NBD C6-Ceramide
Eliglustat	Glucosylceramide Synthase (GCS)	~0.05	In situ (MCF7 cells)	NBD C6-Ceramide

Data extracted from a study on Golgi sphingolipid flux using NBD C6-ceramide and HPLC analysis.

Table 2: IC50 Values of Various Inhibitors for Sphingolipid Metabolizing Enzymes.

Inhibitor	Target Enzyme	IC50	Assay Type
Amitriptyline	Acid Sphingomyelinase (aSMase)	~10 $\mu$ M	Cell-based FRET
Ceranib-2	Ceramidase	0.73 $\mu$ M	Cell-based fluorogenic assay
T-036	Glucosylceramide Synthase (GCS)	31 nM	Enzymatic assay
Miglustat	Glucosylceramide Synthase (GCS)	5-50 $\mu$ M	Enzymatic assay
SB-37	Neutral Ceramidase (nCDase)	0.2-5 $\mu$ M	FRET and NBD- ceramide HPLC

This table compiles data from multiple sources to provide a broader overview of inhibitor potencies.[\[1\]](#)[\[2\]](#)[\[3\]](#)

## Signaling Pathway Visualization

The following diagram illustrates the central pathways of sphingolipid metabolism, highlighting the enzymes that can be targeted and assayed using NBD-labeled sphingolipids.

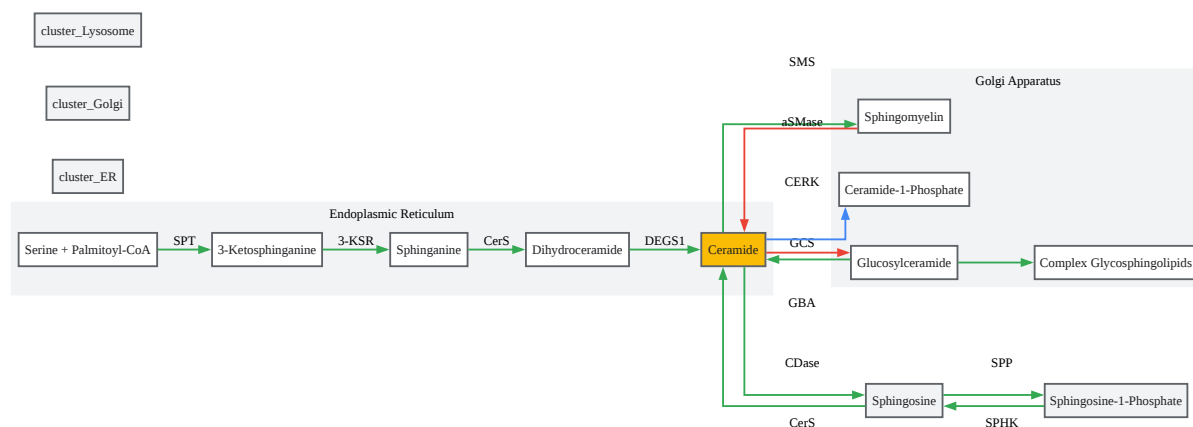

[Click to download full resolution via product page](#)

Caption: Overview of the Sphingolipid Metabolism Pathway.

## Experimental Protocols

### Protocol 1: In Situ Assay for Golgi Sphingolipid Metabolism Using NBD C6-Ceramide

This protocol describes a method to simultaneously measure the activities of Golgi-resident enzymes—sphingomyelin synthase (SMS), glucosylceramide synthase (GCS), and ceramide

kinase (CERK)—by monitoring the metabolism of NBD C6-ceramide in intact cells followed by HPLC analysis.

Materials:

- NBD C6-Ceramide
- Fatty acid-free Bovine Serum Albumin (BSA)
- Phosphate Buffered Saline (PBS)
- Ethanol, absolute
- Cell culture medium (e.g., DMEM)
- Cultured cells (e.g., MCF7) grown in 60 mm dishes
- Methanol
- Chloroform
- HPLC system with a fluorescence detector

Procedure:

- Preparation of NBD C6-Ceramide/BSA Complex (100  $\mu$ M): a. Dry down 100  $\mu$ L of 1 mM NBD C6-ceramide in a glass tube under a stream of nitrogen gas. b. Redissolve the lipid film in 200  $\mu$ L of absolute ethanol. c. Prepare a 0.34 mg/mL solution of fatty acid-free BSA in PBS. d. While vortexing the BSA solution, slowly add the ethanolic NBD C6-ceramide solution to a final volume of 1 mL. e. Store the resulting 100  $\mu$ M NBD C6-Ceramide/BSA complex at -20°C.
- Cell Labeling: a. Plate approximately  $2.5 \times 10^5$  cells per 60 mm dish and grow to the desired confluency. b. For inhibitor studies, pre-treat cells with the desired concentration of inhibitor for the appropriate time (e.g., 4 hours). c. Add the NBD C6-Ceramide/BSA complex directly to the cell culture medium to a final concentration of 1-2  $\mu$ M. d. Incubate the cells for 1 hour at 37°C in a CO<sub>2</sub> incubator.

- Lipid Extraction: a. Aspirate the medium and wash the cells twice with ice-cold PBS. b. Scrape the cells in 1 mL of ice-cold PBS and transfer to a glass tube. c. Pellet the cells by centrifugation (e.g., 500 x g for 5 minutes). d. Add 3 mL of chloroform:methanol (1:2, v/v) to the cell pellet and vortex thoroughly. e. Add 1 mL of chloroform and 1 mL of water to induce phase separation. f. Centrifuge to separate the phases and collect the lower organic phase containing the lipids. g. Dry the lipid extract under a stream of nitrogen.
- HPLC Analysis: a. Reconstitute the dried lipid extract in a suitable solvent (e.g., 100  $\mu$ L of methanol/chloroform). b. Inject an aliquot (e.g., 20  $\mu$ L) onto a reverse-phase HPLC column (e.g., C18). c. Separate the NBD-labeled lipids using an appropriate gradient (e.g., a gradient of methanol in water). d. Detect the fluorescent lipids using a fluorescence detector with excitation at ~470 nm and emission at ~530 nm. e. Quantify the peak areas corresponding to NBD C6-ceramide, NBD C6-sphingomyelin, NBD C6-glucosylceramide, and NBD C6-ceramide-1-phosphate.

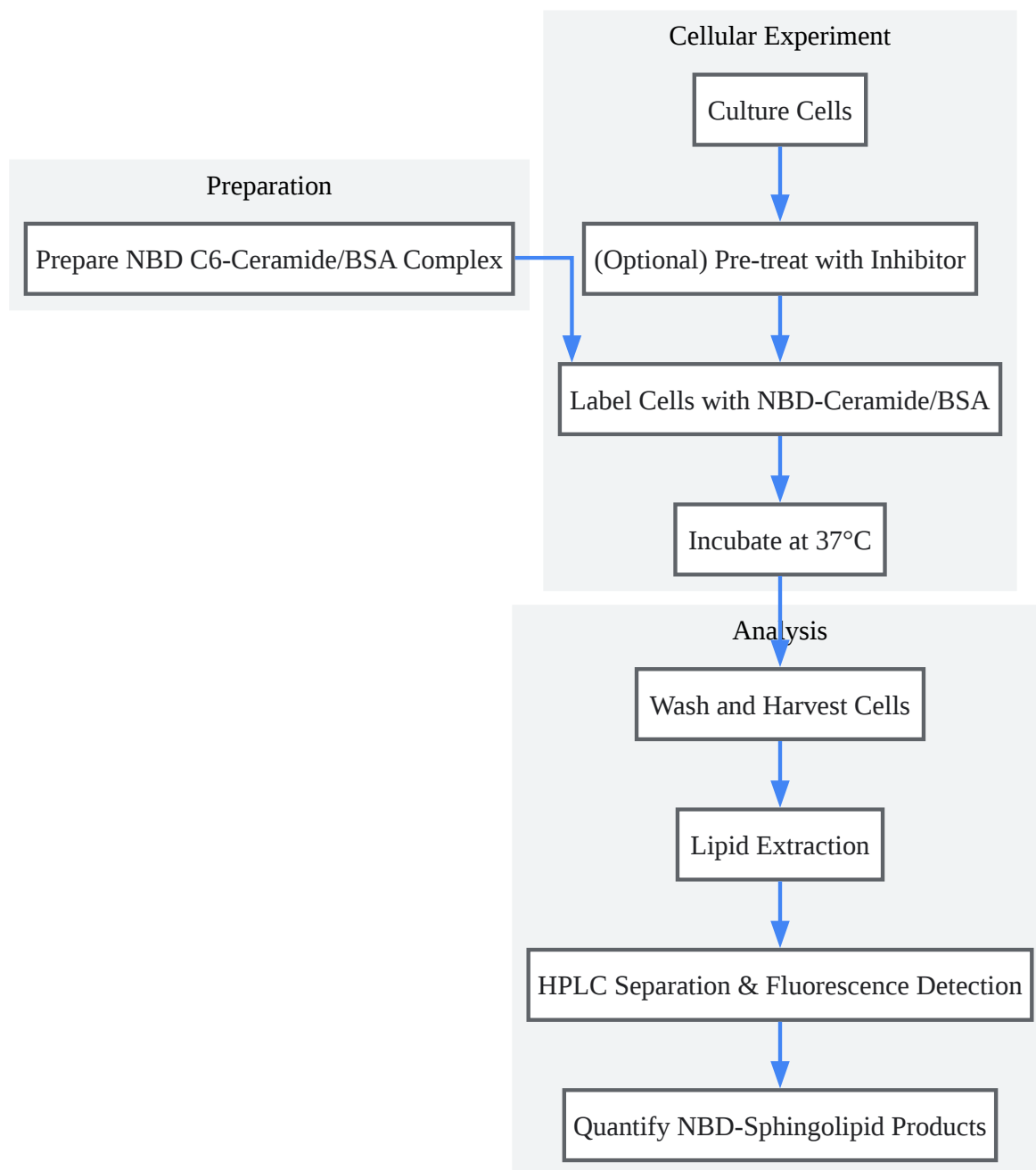

[Click to download full resolution via product page](#)

Caption: Experimental workflow for in situ Golgi sphingolipid metabolism assay.

## Protocol 2: In Vitro FRET Assay for Acid Sphingomyelinase (aSMase) Activity

This protocol outlines a continuous, in vitro FRET-based assay to measure the activity of acid sphingomyelinase using a doubly-labeled sphingomyelin substrate.

### Materials:

- Recombinant human acid sphingomyelinase (aSMase)
- FRET-based aSMase substrate (e.g., NBD-labeled sphingomyelin with a suitable FRET partner)
- Assay Buffer: Sodium acetate buffer (e.g., 50 mM, pH 4.5-5.5) containing a non-ionic detergent (e.g., 0.1% Triton X-100 or NP-40).
- 96-well black microplate, low-binding
- Fluorescence microplate reader capable of kinetic measurements

### Procedure:

- Reagent Preparation: a. Prepare a stock solution of the FRET substrate in an appropriate solvent (e.g., DMSO or ethanol). b. Prepare serial dilutions of the test inhibitors in the assay buffer. c. Prepare a working solution of recombinant aSMase in the assay buffer. Keep on ice.
- Assay Setup: a. In a 96-well microplate, add the following to each well:
  - Assay Buffer
  - Test inhibitor or vehicle control
  - FRET substrate (final concentration typically in the low micromolar range) b. Mix gently and pre-incubate the plate at 37°C for 5-10 minutes to allow the inhibitor to interact with the substrate if necessary and to equilibrate the temperature.
- Enzyme Reaction and Measurement: a. Initiate the reaction by adding the aSMase working solution to each well. b. Immediately place the microplate in the fluorescence plate reader

pre-heated to 37°C. c. Measure the fluorescence of the FRET donor and acceptor channels kinetically over a period of time (e.g., every minute for 30-60 minutes).

- Set the excitation and emission wavelengths appropriate for the specific FRET pair used. For an NBD acceptor, excitation of the donor would be in the blue region of the spectrum, with emission monitored for both the donor and NBD.
- Data Analysis: a. For each time point, calculate the FRET ratio (e.g.,  $\text{Acceptor Emission} / \text{Donor Emission}$  or  $\text{Acceptor Emission} / (\text{Acceptor Emission} + \text{Donor Emission})$ ). b. Plot the FRET ratio against time to obtain the reaction progress curves. c. The initial rate of the reaction is determined from the linear portion of the progress curve. d. To determine IC50 values, plot the initial reaction rates against the logarithm of the inhibitor concentration and fit the data to a dose-response curve.

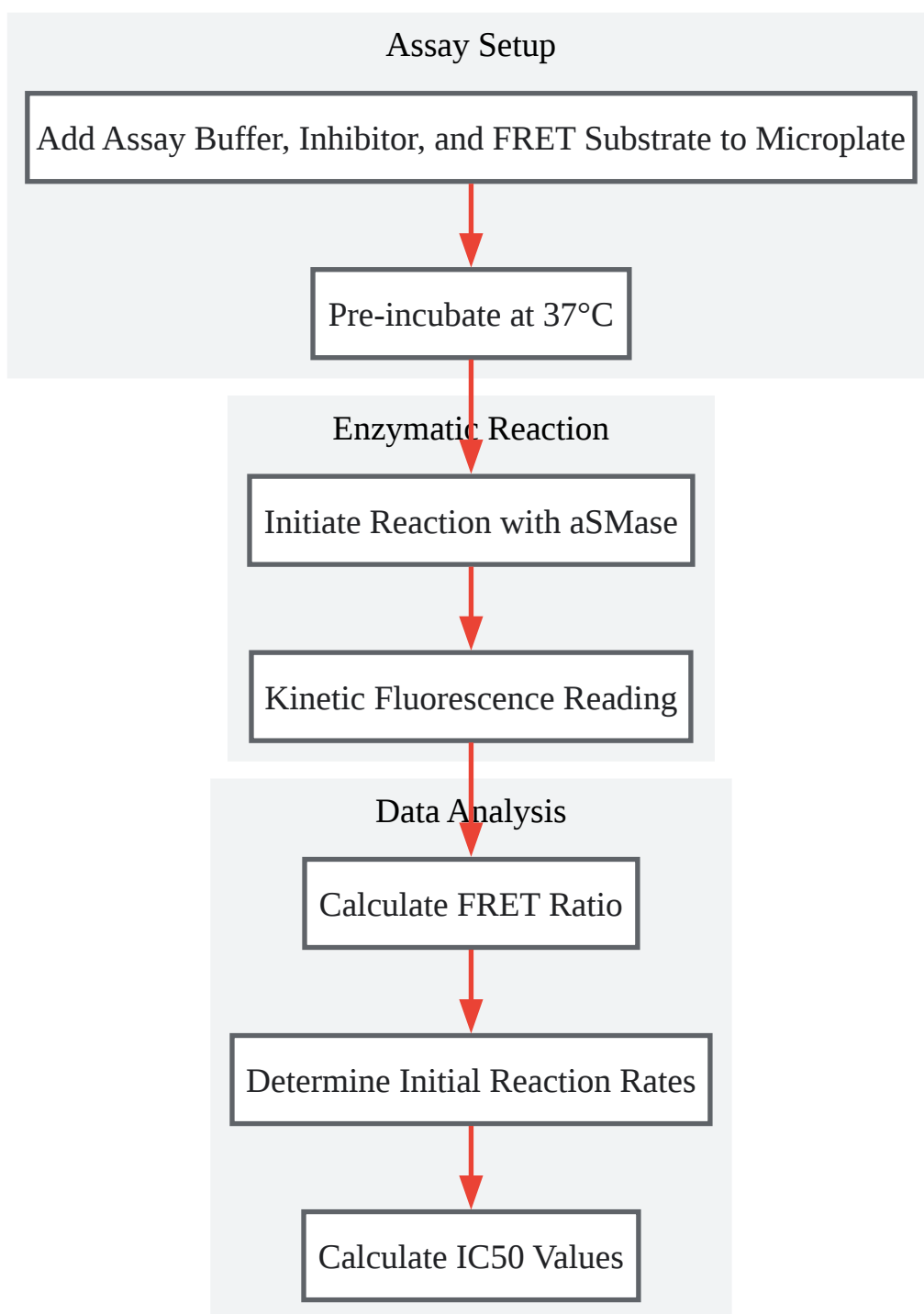

[Click to download full resolution via product page](#)

#### Need Custom Synthesis?

BenchChem offers custom synthesis for rare earth carbides and specific isotopic labeling.

Email: [info@benchchem.com](mailto:info@benchchem.com) or [Request Quote Online](#).

## References

- [1. A Novel Visible Range FRET Probe for Monitoring Acid Sphingomyelinase Activity in Living Cells - PMC \[pmc.ncbi.nlm.nih.gov\]](#)
- [2. Discovery and Evaluation of Inhibitors of Human Ceramidase - PMC \[pmc.ncbi.nlm.nih.gov\]](#)
- [3. A new brain-penetrant glucosylceramide synthase inhibitor as potential Therapeutics for Gaucher disease - PMC \[pmc.ncbi.nlm.nih.gov\]](#)
- To cite this document: BenchChem. [Application Notes and Protocols for FRET-Based Assays Using NBD-Labeled Sphingolipids]. BenchChem, [2026]. [Online PDF]. Available at: [\[https://www.benchchem.com/product/b569086/docs#application-notes-and-protocols-for-fret-based-assays-using-nbd-labeled-sphingolipids\]](https://www.benchchem.com/product/b569086/docs#application-notes-and-protocols-for-fret-based-assays-using-nbd-labeled-sphingolipids)

---

### Disclaimer & Data Validity:

The information provided in this document is for Research Use Only (RUO) and is strictly not intended for diagnostic or therapeutic procedures. While BenchChem strives to provide accurate protocols, we make no warranties, express or implied, regarding the fitness of this product for every specific experimental setup.

**Technical Support:** The protocols provided are for reference purposes. Unsure if this reagent suits your experiment?

**Need Industrial/Bulk Grade?** [Request Custom Synthesis Quote](#)

## BenchChem

Our mission is to be the trusted global source of essential and advanced chemicals, empowering scientists and researchers to drive progress in science and industry.

### Contact

Address: 3281 E Guasti Rd

Ontario, CA 91761, United States

Phone: (601) 213-4426

Email: [info@benchchem.com](mailto:info@benchchem.com)

Contact our Ph.D. Support Team for a compatibility check