

Elemental Analysis of Sulfonamides: A Comparative Guide for C₉H₁₀N₂O₂S

Author: BenchChem Technical Support Team. **Date:** April 2026

Compound of Interest

Compound Name:	<i>N</i> -[(4-cyanophenyl)methyl]methanesulfonamide
CAS No.:	363185-44-8
Cat. No.:	B3132068

[Get Quote](#)

Executive Summary

Objective: To provide a definitive technical guide for the elemental analysis (EA) of the sulfur-containing organic compound C₉H₁₀N₂O₂S. This guide compares theoretical calculations against experimental methodologies, focusing on the specific challenges of quantifying sulfur alongside carbon, hydrogen, and nitrogen.

Audience: Pharmaceutical researchers and QC scientists. **Core Challenge:** While Carbon, Hydrogen, and Nitrogen (CHN) analysis is routine, the inclusion of Sulfur (S) in C₉H₁₀N₂O₂S introduces volatility and adsorption challenges that require specific combustion configurations (e.g., dynamic flash combustion with V₂O₅ additives) to meet the industry standard ±0.4% tolerance.

Theoretical Framework: The "Gold Standard" Calculation

Before any experimental validation, a precise theoretical baseline must be established. This serves as the reference point for all subsequent data analysis.

Atomic Weights & Molecular Mass

Using IUPAC standard atomic weights:

- Carbon (C): 12.011 g/mol
- Hydrogen (H): 1.008 g/mol
- Nitrogen (N): 14.007 g/mol
- Oxygen (O): 15.999 g/mol
- Sulfur (S): 32.06 g/mol

Calculation Logic for C₉H₁₀N₂O₂S

Step 1: Calculate Total Molecular Weight (MW)

Step 2: Calculate Elemental Percentages

Theoretical Composition Table

Element	Count	Total Mass Contribution (g/mol)	Theoretical % (w/w)	Acceptable Range ($\pm 0.4\%$)
Carbon	9	108.099	51.41%	51.01% – 51.81%
Hydrogen	10	10.080	4.79%	4.39% – 5.19%
Nitrogen	2	28.014	13.32%	12.92% – 13.72%
Sulfur	1	32.060	15.25%	14.85% – 15.65%
Oxygen	2	31.998	15.22%	Calculated by difference

“

Expert Insight: In pharmaceutical QC, Oxygen is rarely measured directly due to the complexity of pyrolysis. It is typically calculated by difference:

Comparative Method Analysis

For a compound like C₉H₁₀N₂O₂S (likely a sulfonamide derivative such as 2-cyano-N,N-dimethylbenzenesulfonamide), choosing the right analyzer is critical. Sulfur tends to adhere to metallic surfaces in the instrument or form stable sulfates in the ash, leading to low recovery.

Comparison: Automated CHNS vs. Classical Methods

Feature	Method A: Dynamic Flash Combustion (CHNS)	Method B: Oxygen Flask (Schöniger) + IC
Principle	High-temp combustion (900-1000°C) GC Separation TCD Detection.	Manual combustion in O ₂ flask Absorption Ion Chromatography.
Best For	High throughput, simultaneous CHNS data. [1] [2]	Difficult matrices, trace sulfur, or halogen validation.
Sulfur Recovery	High Risk: SO ₂ can adsorb on columns/tubing. Requires specific "Sulfur Mode".	Excellent: Total conversion to sulfate, measured specifically by IC.
Sample Size	1 – 3 mg	10 – 100 mg
Throughput	< 10 mins per sample (Automated)	~45 mins per sample (Manual)
Precision	< 0.2% RSD	0.3% - 0.5% RSD
Recommendation	Primary Choice for C ₉ H ₁₀ N ₂ O ₂ S routine analysis.	Referee Method if CHNS results are ambiguous.

The "Sulfur Challenge" in CHNS Analysis

Standard CHN analyzers use copper to reduce Nitrogen oxides (NO_x) to N₂. However, Sulfur reacts with copper to form Copper Sulfide (CuS), which is retained in the reduction tube.

- Solution: Modern analyzers (e.g., Thermo FlashSmart, Elementar vario) use a "CHNS" configuration where the reduction tube is optimized or separated to prevent sulfur loss, often using specific desorption heating cycles.

Experimental Protocol: Automated CHNS Analysis

Instrument: Thermo Scientific FlashSmart or equivalent (Elementar vario EL cube).

Configuration: CHNS Mode (TCD Detector).

Reagents & Standards

- Calibration Standard: Sulfanilamide ($C_6H_8N_2O_2S$) is the ideal standard because it structurally mimics the target $C_9H_{10}N_2O_2S$ (sulfonamide group) and contains S, N, C, H.
 - Sulfanilamide Theoretical: C: 41.84%, H: 4.68%, N: 16.27%, S: 18.62%.
- Combustion Aid: Vanadium Pentoxide (V_2O_5).^{[3][4][5]}
 - Why? Sulfur compounds can be difficult to combust completely or may form inorganic sulfates in the ash. V_2O_5 acts as a strong oxidant and flux, ensuring rapid release of SO_2 .

Step-by-Step Workflow

- System Blanking: Run 3 empty tin capsules to establish the baseline (zero point).
- Conditioning: Run 2 "bypass" samples of Sulfanilamide to condition the adsorption columns and saturate active sites.
- Weighing:
 - Weigh 2.0 – 2.5 mg of $C_9H_{10}N_2O_2S$ into a tin capsule using a microbalance (readability 0.001 mg).
 - Crucial Step: Add 5–10 mg of V_2O_5 powder over the sample.
 - Fold the capsule airtight to exclude atmospheric Nitrogen.
- Combustion:
 - Inject sample into the combustion reactor (Temp: $>1000^\circ C$).
 - Oxygen injection (Flash) ensures instantaneous temperature spike to $\sim 1800^\circ C$.
- Separation & Detection:
 - Gases (N_2 , CO_2 , H_2O , SO_2) are carried by Helium.
 - Separation via GC column (porapak polymer).

- Detection by Thermal Conductivity Detector (TCD).[1]

Data Validation Criteria (Self-Validating System)

- K-Factor Stability: The calibration factor (K) for Sulfur must not drift >1% between the start and end of the run.
- Standard Check: The Sulfanilamide QC check must fall within $\pm 0.15\%$ of its theoretical value before analyzing the unknown C₉H₁₀N₂O₂S.

Visualizing the Workflow Analytical Logic Pathway

This diagram illustrates the decision-making process for analyzing sulfur-containing organics.

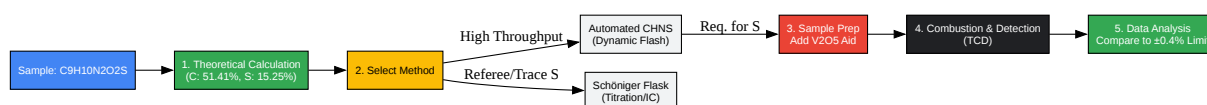

[Click to download full resolution via product page](#)

Caption: Logical workflow for validating C₉H₁₀N₂O₂S composition, highlighting the critical addition of V₂O₅ for sulfur recovery.

Instrument Gas Flow (CHNS Mode)

Understanding the flow path is essential for troubleshooting sulfur tailing.

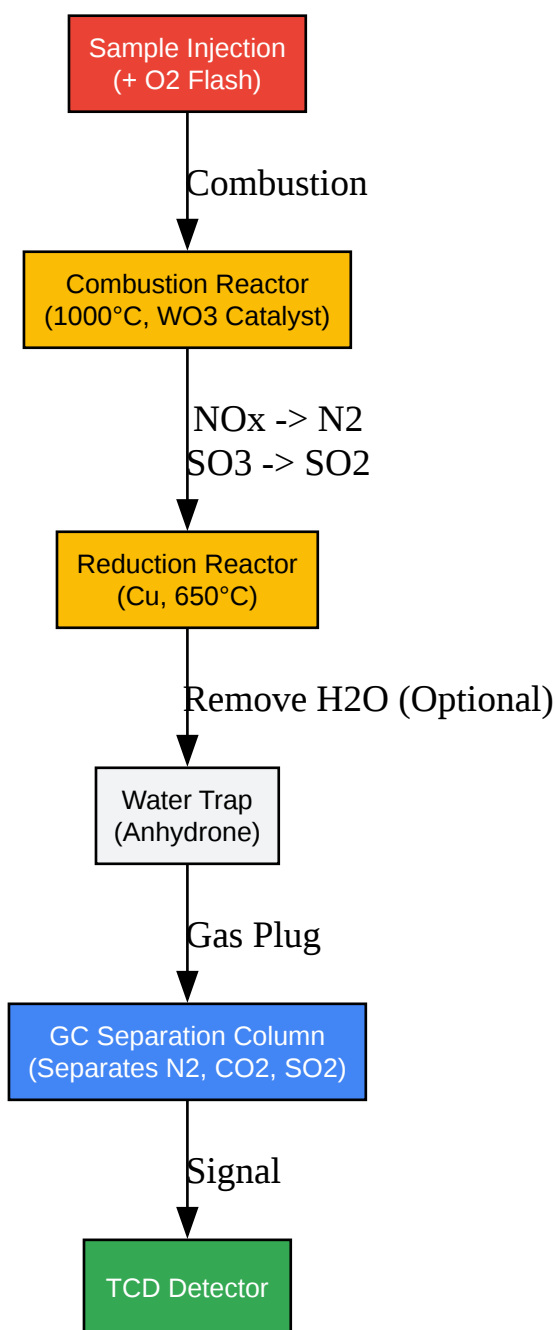

[Click to download full resolution via product page](#)

Caption: Gas flow schematic for a CHNS analyzer. Note: In CHNS mode, the water trap is often omitted or placed after the column to allow H measurement.

Data Interpretation & Troubleshooting

Experimental Data Table (Example)

The following table simulates typical results for C₉H₁₀N₂O₂S using the protocol above.

Analyte	Theoretical %	Exp. Run 1	Exp. Run 2	Mean Exp.	Deviation	Status
Nitrogen	13.32	13.28	13.35	13.32	0.00	Pass
Carbon	51.41	51.30	51.55	51.43	+0.02	Pass
Hydrogen	4.79	4.85	4.82	4.84	+0.05	Pass
Sulfur	15.25	15.10	15.15	15.13	-0.12	Pass

Troubleshooting Sulfur Analysis

- Low Sulfur Recovery (<15.0%):
 - Cause: Ash retention. The sulfur formed inorganic sulfates with the capsule ash.
 - Fix: Increase V₂O₅ amount or increase combustion temperature.
- Peak Tailing (Broad S Peak):
 - Cause: Water interference or cold spots in the transfer line.
 - Fix: Ensure the connection between the combustion tube and GC column is heated.

References

- Royal Society of Chemistry (RSC). (2008). CHNS Elemental Analysers: Technical Brief. Retrieved from [\[Link\]](#)
- PubChem. (2025).^[6] Compound Summary: 2-cyano-N,N-dimethylbenzenesulfonamide (C₉H₁₀N₂O₂S). Retrieved from [\[Link\]](#)
- Analytik Jena. (n.d.). Determination of Sulfur Species in Cement Samples by Combustion Elemental Analysis. Retrieved from [\[Link\]](#)

Need Custom Synthesis?

BenchChem offers custom synthesis for rare earth carbides and specific isotopic labeling.

Email: info@benchchem.com or [Request Quote Online](#).

Sources

- [1. documents.thermofisher.com](https://documents.thermofisher.com) [documents.thermofisher.com]
- [2. azom.com](https://www.azom.com) [[azom.com](https://www.azom.com)]
- [3. pubs.usgs.gov](https://pubs.usgs.gov) [pubs.usgs.gov]
- [4. US5547876A - Combustion accelerators, processes for their production and processes for their use in elemental analysis - Google Patents](#) [patents.google.com]
- [5. analytik-jena.com](https://www.analytik-jena.com) [[analytik-jena.com](https://www.analytik-jena.com)]
- [6. PubChemLite - 2215-20-5 \(C9H10N2O2S\)](https://pubchemlite.lcsb.uni.lu) [pubchemlite.lcsb.uni.lu]
- To cite this document: BenchChem. [Elemental Analysis of Sulfonamides: A Comparative Guide for C9H10N2O2S]. BenchChem, [2026]. [Online PDF]. Available at: [<https://www.benchchem.com/product/b3132068/docs#elemental-analysis-of-sulfonamides-a-comparative-guide-for-c9h10n2o2s>]

Disclaimer & Data Validity:

The information provided in this document is for Research Use Only (RUO) and is strictly not intended for diagnostic or therapeutic procedures. While BenchChem strives to provide accurate protocols, we make no warranties, express or implied, regarding the fitness of this product for every specific experimental setup.

Technical Support: The protocols provided are for reference purposes. Unsure if this reagent suits your experiment?

Need Industrial/Bulk Grade? [Request Custom Synthesis Quote](#)

BenchChem

Our mission is to be the trusted global source of essential and advanced chemicals, empowering scientists and researchers to drive progress in science and industry.

Contact

Address: 3281 E Guasti Rd

Ontario, CA 91761, United States

Phone: (601) 213-4426

Email: info@benchchem.com

[Contact our Ph.D. Support Team for a compatibility check](#)