

Technical Guide: Mass Spectrometry Fragmentation of Brominated Indole Esters

Author: BenchChem Technical Support Team. **Date:** April 2026

Compound of Interest

Compound Name: Ethyl 6-bromo-3-formyl-1H-indole-2-carboxylate
CAS No.: 318292-54-5
Cat. No.: B3124466

[Get Quote](#)

Content Type: Publish Comparison Guide Audience: Researchers, Medicinal Chemists, and Drug Development Professionals Focus: Structural elucidation, isotopic pattern analysis, and mechanistic fragmentation pathways.

Executive Summary

Brominated indole esters represent a critical scaffold in marine natural products (e.g., Aplysinopsins) and synthetic medicinal chemistry (e.g., antiviral and anticancer agents). Their mass spectrometric (MS) analysis offers a distinct advantage: the bromine atom acts as an intrinsic isotopic label, providing a high-fidelity "fingerprint" that aids in filtering complex biological matrices.

This guide objectively compares the fragmentation behavior of brominated indole esters against non-halogenated and chlorinated analogs. It details the specific cleavage pathways—driven by the stability of the indole core and the lability of the ester function—and provides a robust protocol for their identification.

The Isotopic Fingerprint: Bromine vs. Alternatives

The first step in validating a brominated indole ester is not fragmentation, but isotopic pattern recognition. Unlike fluorine (monoisotopic) or chlorine (3:1 ratio), bromine possesses a unique signature that is diagnostic even at low resolution.

Comparative Isotopic Signatures

Feature	Brominated Indole ()	Chlorinated Indole ()	Non-Halogenated
M+2 Ratio	1:1 (approx. 100:97)	3:1 (approx. 100:32)	< 1% (due to)
Visual Appearance	"Doublet" of equal height	"Doublet" with second peak 1/3 height	Single dominant peak
Mass Shift	+78.9183 Da (vs. H)	+33.9610 Da (vs. H)	N/A
Diagnostic Value	High (Unambiguous confirmation)	Moderate (Common in solvents/contaminants)	Low (Requires high-res MS)

“

Expert Insight: In LC-MS data processing, set your isotope filter to recognize the 1:1 doublet with a mass difference of 2.0 Da. This effectively removes >95% of background noise from biological matrices.

Fragmentation Mechanisms: The "Decision Tree"

The fragmentation of brominated indole esters under Electron Ionization (EI) or Collision-Induced Dissociation (CID) follows three competitive pathways. The dominance of a pathway depends on the ester chain length and the position of the bromine.

Representative Molecule: Methyl 5-bromoindole-3-carboxylate ()

- Precursor Ions: m/z 253 () and 255 ().

Pathway A: Ester Cleavage (The Primary Route)

The most abundant fragment usually arises from the cleavage of the alkoxy group () or the entire ester moiety ().

- α -Cleavage: Loss of the alkoxy radical (e.g., -31 Da) generates the stable acylium ion.
 - m/z 253
222 ()
- Carbonyl Loss: Subsequent loss of -28 Da from the acylium ion yields the bromoindole cation.
 - m/z 222
194 ()

Pathway B: Indole Ring Fragmentation (The Diagnostic Route)

Once the ester side chain is removed, the indole core undergoes characteristic fragmentation.

- HCN Loss: The pyrrole ring of the indole opens and ejects hydrogen cyanide (HCN, -27 Da). This is the hallmark of all indole alkaloids.
 - m/z 194
 - 167 (
 -)
- C₂H₂ Loss: In some cases, a loss of acetylene (-26 Da) is observed, though HCN loss is kinetically favored.

Pathway C: Debromination (The Radical Route)

Aromatic bromine bonds are relatively strong, but under high collision energies (CID > 35 eV), homolytic cleavage of the

bond occurs.

- Radical Loss: Loss of
(-79/81 Da).
 - m/z 253
 - 174 (Radical cation, rare in ESI, common in EI).
- HBr Loss: In ESI(+), a rearrangement may lead to the loss of neutral HBr (-80/82 Da), restoring the double bond or forming a radical cation.

Visualization: Fragmentation Topology

The following diagram maps the fragmentation tree for Methyl 5-bromoindole-3-carboxylate.

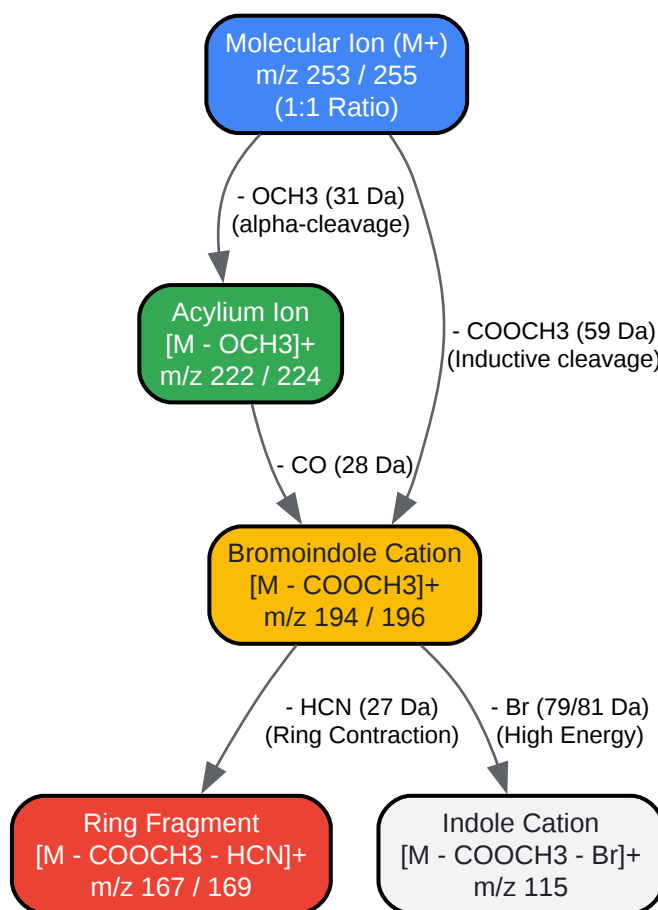

[Click to download full resolution via product page](#)

Figure 1: Fragmentation pathway of Methyl 5-bromoindole-3-carboxylate. Note the persistence of the bromine doublet until the final debromination step.

Comparative Performance Guide

Scenario 1: Brominated vs. Non-Brominated Indole Esters

Challenge: Distinguishing the synthetic brominated derivative from the natural non-brominated precursor (e.g., Indole-3-acetic acid methyl ester).

Parameter	Brominated Derivative	Non-Brominated Analog
Base Peak (EI)	Often m/z 194/196 (Core stability)	Often m/z 130 (Quinolinium ion)
McLafferty Rearrangement	Suppressed due to steric/electronic effect of Br	Prominent if alkyl chain > C3
Retention Time (RP-LC)	Longer (Increased lipophilicity)	Shorter

Scenario 2: Esters vs. Amides (Synthetic Cannabinoids)

Context: Many synthetic drugs (e.g., JWH-series) use indole-3-carbonyl cores.

- Esters: Readily lose the alkoxy group ().^[1] The transition from to is low energy.
- Amides: The amide bond is more robust. Fragmentation often involves cleavage of the N-alkyl chain on the indole nitrogen before the amide bond breaks.
- Key Differentiator: If you see a loss of 31, 45, or 59 Da (alkoxy) early in the pathway, it is an ester. If you see stable alkyl losses (e.g., -15, -29) while the core remains intact, it is likely an amide.

Experimental Protocol: Validated Workflow

To replicate these results, utilize the following conditions. This protocol is optimized for ESI-MS/MS but compatible with EI-GC-MS with noted adjustments.

Sample Preparation

- Solvent: Dissolve sample in Methanol (MeOH) to 10 µg/mL.
- Additive: Add 0.1% Formic Acid to enhance protonation (

).

- Filtration: 0.22 μm PTFE filter (Brominated compounds can adsorb to Nylon).

Mass Spectrometry Settings (LC-Q-ToF or Orbitrap)[2][3]

- Ionization: Electrospray Ionization (ESI) Positive Mode.[2][3]
- Capillary Voltage: 3.5 kV.
- Source Temp: 300°C.
- Collision Energy (CE): Stepped CE (20, 35, 50 eV).
 - Why? Low CE (20 eV) preserves the M+2 doublet for identification. High CE (50 eV) forces the diagnostic HCN loss.

Data Analysis Steps

- Extract Ion Chromatogram (EIC): Search for the specific m/z pair (e.g., 253.9/255.9).
- Check Ratio: Verify the peak height ratio is between 0.9 and 1.1.
- MS2 Confirmation: Look for the "Delta 28" (CO loss) and "Delta 27" (HCN loss) sequence.

References

- Marine Indole Alkaloids & Fragmentation
 - Source: N
 - Title: Marine Indole Alkaloids: Isolation and Mass Spectrometric Characterization[4]
 - URL:[[Link](#)]
- Synthetic Cannabinoid Fragmentation (Indole-3-carbonyls)
 - Source: PubMed

- Title: Development of a fragmentation pattern of synthetic cannabinoids based on ESI-MS[2][5][6]
- URL:[[Link](#)]
- General Mass Spectrometry of Halogenated Compounds
 - Source: Chemistry LibreTexts
 - Title: Mass Spectrometry - Fragmentation Patterns (Halides)[1]
 - URL:[[Link](#)]
- Indole Ring Fragmentation Mechanisms
 - Source: Scientific Research Publishing
 - Title: Study of Mass Spectra of Some Indole Derivatives[2][5][3][4][7][8][9]
 - URL:[[Link](#)]

Need Custom Synthesis?

BenchChem offers custom synthesis for rare earth carbides and specific isotopic labeling.

Email: info@benchchem.com or [Request Quote Online](#).

Sources

- [1. chem.libretexts.org](https://chem.libretexts.org) [chem.libretexts.org]
- [2. researchgate.net](https://researchgate.net) [researchgate.net]
- [3. scialert.net](https://scialert.net) [scialert.net]
- [4. Mass Spectrometric Characteristics of Prenylated Indole Derivatives from Marine-Derived Penicillium sp. NH-SL - PMC](https://pubmed.ncbi.nlm.nih.gov/21111111/) [[pmc.ncbi.nlm.nih.gov](https://pubmed.ncbi.nlm.nih.gov/21111111/)]
- [5. Development of a fragmentation pattern of synthetic cannabinoids based on electrospray ionization mass spectrometry in positive ion mode to screen synthetic cannabinoids in illicit products - PubMed](https://pubmed.ncbi.nlm.nih.gov/21111111/) [[pubmed.ncbi.nlm.nih.gov](https://pubmed.ncbi.nlm.nih.gov/21111111/)]

- [6. researchgate.net \[researchgate.net\]](#)
- [7. Study of Mass Spectra of Some Indole Derivatives \[scirp.org\]](#)
- [8. mdpi.com \[mdpi.com\]](#)
- [9. mdpi.com \[mdpi.com\]](#)
- To cite this document: BenchChem. [Technical Guide: Mass Spectrometry Fragmentation of Brominated Indole Esters]. BenchChem, [2026]. [Online PDF]. Available at: [\[https://www.benchchem.com/product/b3124466/docs#technical-guide-mass-spectrometry-fragmentation-of-brominated-indole-esters\]](https://www.benchchem.com/product/b3124466/docs#technical-guide-mass-spectrometry-fragmentation-of-brominated-indole-esters)

Disclaimer & Data Validity:

The information provided in this document is for Research Use Only (RUO) and is strictly not intended for diagnostic or therapeutic procedures. While BenchChem strives to provide accurate protocols, we make no warranties, express or implied, regarding the fitness of this product for every specific experimental setup.

Technical Support: The protocols provided are for reference purposes. Unsure if this reagent suits your experiment?

Need Industrial/Bulk Grade? [Request Custom Synthesis Quote](#)

BenchChem

Our mission is to be the trusted global source of essential and advanced chemicals, empowering scientists and researchers to drive progress in science and industry.

Contact

Address: 3281 E Guasti Rd
Ontario, CA 91761, United States
Phone: (601) 213-4426
Email: info@benchchem.com

[Contact our Ph.D. Support Team for a compatibility check](#)

