

Preliminary Research on 3-Azathalidomide Effects: A Technical Guide

Author: BenchChem Technical Support Team. **Date:** April 2026

Compound of Interest

Compound Name: 3-Azathalidomide

CAS No.: 31804-66-7

Cat. No.: B3124321

[Get Quote](#)

Disclaimer: Direct experimental data on **3-Azathalidomide** is limited in publicly available scientific literature. This guide provides a comprehensive overview of the known effects of its parent compound, thalidomide, and its close analogs. The information presented here serves as a foundational resource for researchers, scientists, and drug development professionals, offering insights into the potential biological activities of **3-Azathalidomide**. All data and experimental protocols are based on studies of thalidomide and its derivatives and should be considered as a starting point for specific research on **3-Azathalidomide**.

Core Concepts: Anti-Angiogenic, Immunomodulatory, and Anti-Proliferative Effects

Thalidomide and its analogs are a class of immunomodulatory drugs known for their potent anti-neoplastic, anti-angiogenic, and anti-inflammatory properties.[1] The primary mechanisms of action include the inhibition of tumor necrosis factor-alpha (TNF- α), modulation of the tumor microenvironment, and direct effects on tumor cell proliferation and survival.[2]

Quantitative Data: In Vitro Cytotoxicity of Thalidomide Analogs

The following table summarizes the half-maximal inhibitory concentration (IC₅₀) values of various thalidomide analogs against a panel of human cancer cell lines. This data provides a comparative baseline for the potential cytotoxic effects of **3-Azathalidomide**.

Compound/Analog	Cell Line	IC50 (μM)	Reference
Thalidomide	HepG-2 (Hepatocellular Carcinoma)	32.12	[3]
Thalidomide	HCT-116 (Colorectal Carcinoma)	76.91	[3]
Thalidomide	PC3 (Prostate Cancer)	Not specified	[3]
Thalidomide	MCF-7 (Breast Cancer)	Not specified	[3]
Analog 33h	HepG-2	14.63	[3]
Analog 33h	HCT-116	25.81	[3]
Analog 33h	PC3	33.42	[3]
Analog 33h	MCF-7	21.50	[3]
Analog 33i	HepG-2	22.47	[3]
Analog 33i	HCT-116	18.33	[3]
Analog 33i	PC3	29.87	[3]
Analog 33i	MCF-7	19.64	[3]
Analog 42f	HepG-2	28.19	[3]
Analog 42f	HCT-116	15.24	[3]
Analog 42f	PC3	24.76	[3]
Analog 42f	MCF-7	16.92	[3]
Analog 42h	HepG-2	31.55	[3]
Analog 42h	HCT-116	49.90	[3]
Analog 42h	PC3	41.28	[3]
Analog 42h	MCF-7	38.71	[3]

Experimental Protocols

In Vitro Anti-Proliferative Activity (MTT Assay)

This protocol is a standard method for assessing the cytotoxic effects of a compound on cultured cancer cells.

Objective: To determine the concentration of a test compound that inhibits cell growth by 50% (IC₅₀).

Methodology:

- Cell Seeding: Plate cancer cells (e.g., HepG-2, HCT-116, PC3, MCF-7) in 96-well plates at a density of 5×10^4 cells/well and incubate for 24 hours.
- Compound Treatment: Treat the cells with various concentrations of the test compound (e.g., **3-Azathalidomide**) and a vehicle control.
- Incubation: Incubate the plates for 48 hours.
- MTT Addition: Add 3-(4,5-dimethylthiazol-2-yl)-2,5-diphenyltetrazolium bromide (MTT) solution to each well and incubate for 1-4 hours.
- Formazan Solubilization: Add a solubilizing agent (e.g., DMSO) to dissolve the formazan crystals.
- Absorbance Measurement: Measure the absorbance at 570 nm using a microplate reader.
- Data Analysis: Calculate the percentage of cell viability relative to the control and determine the IC₅₀ value.

In Vitro Angiogenesis Assay (Tube Formation Assay)

This assay evaluates the effect of a compound on the formation of capillary-like structures by endothelial cells.

Objective: To assess the anti-angiogenic potential of a test compound.

Methodology:

- **Matrigel Coating:** Coat the wells of a 96-well plate with Matrigel and allow it to solidify.
- **Cell Seeding:** Seed human umbilical vein endothelial cells (HUVECs) onto the Matrigel-coated wells.
- **Compound Treatment:** Treat the cells with the test compound at various concentrations.
- **Incubation:** Incubate the plates for 6-12 hours to allow for tube formation.
- **Visualization and Quantification:** Stain the cells with a fluorescent dye (e.g., Calcein AM) and visualize the tube network using a fluorescence microscope. Quantify the tube length and number of branch points using image analysis software.

TNF- α Inhibition Assay

This assay measures the ability of a compound to inhibit the production of TNF- α in stimulated immune cells.

Objective: To determine the inhibitory effect of a test compound on TNF- α secretion.

Methodology:

- **Cell Stimulation:** Use human peripheral blood mononuclear cells (PBMCs) or a monocytic cell line (e.g., THP-1). Stimulate the cells with lipopolysaccharide (LPS) to induce TNF- α production.
- **Compound Treatment:** Co-incubate the stimulated cells with various concentrations of the test compound.
- **Incubation:** Incubate for a specified period (e.g., 4-24 hours).
- **TNF- α Measurement:** Collect the cell culture supernatant and measure the concentration of TNF- α using an Enzyme-Linked Immunosorbent Assay (ELISA) kit.
- **Data Analysis:** Calculate the percentage of TNF- α inhibition compared to the LPS-stimulated control.

Signaling Pathways

The biological effects of thalidomide and its analogs are mediated through the modulation of several key signaling pathways.

Inhibition of TNF- α Signaling

Thalidomide and its analogs are well-known inhibitors of TNF- α production.^[4] This is a crucial aspect of their anti-inflammatory and immunomodulatory activities. The proposed mechanism involves the destabilization of TNF- α mRNA.

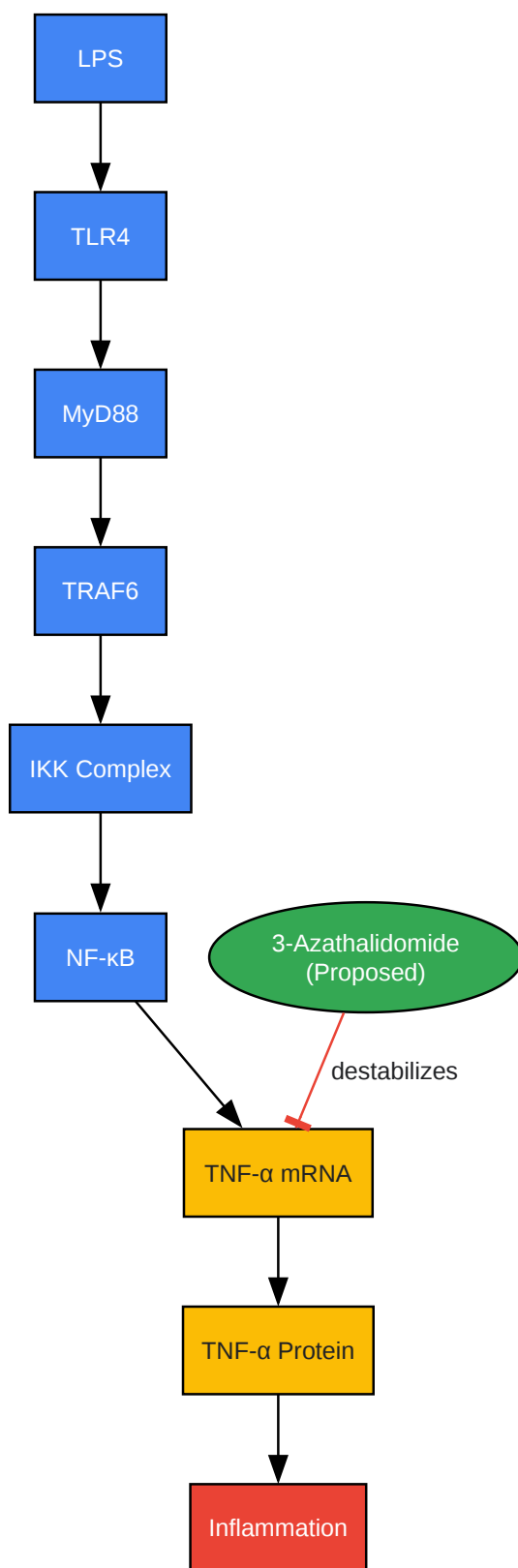

[Click to download full resolution via product page](#)

Caption: Proposed mechanism of TNF- α inhibition by **3-Azathalidomide**.

Anti-Angiogenic Signaling Pathway

Thalidomide and its analogs inhibit angiogenesis by targeting key growth factors and their signaling cascades, such as Vascular Endothelial Growth Factor (VEGF).

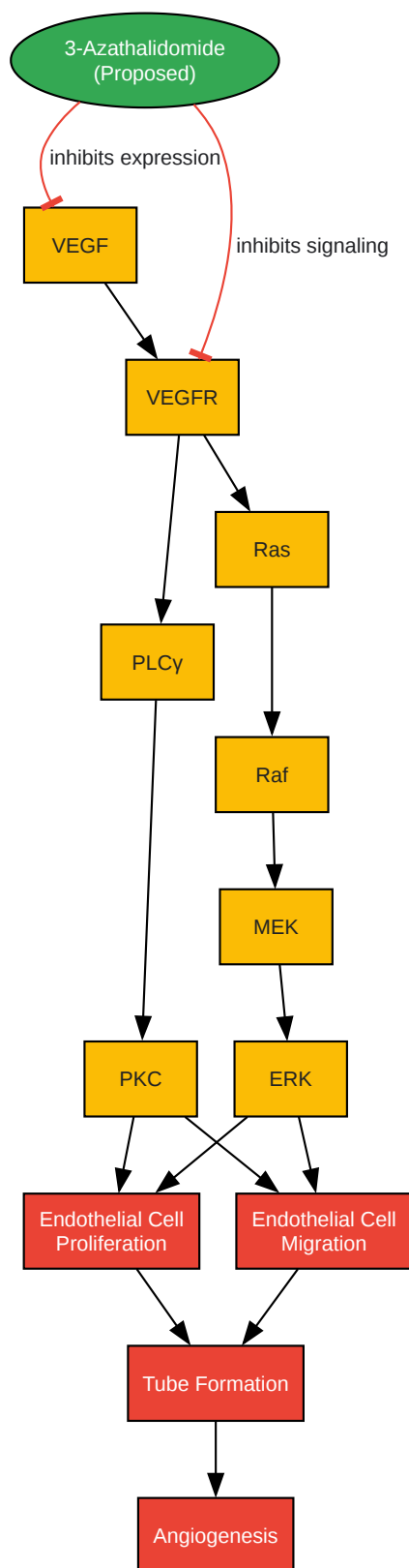

[Click to download full resolution via product page](#)

Caption: Proposed anti-angiogenic signaling pathway of **3-Azathalidomide**.

Experimental Workflow

The following diagram outlines a typical workflow for the preliminary in vitro evaluation of a compound like **3-Azathalidomide**.

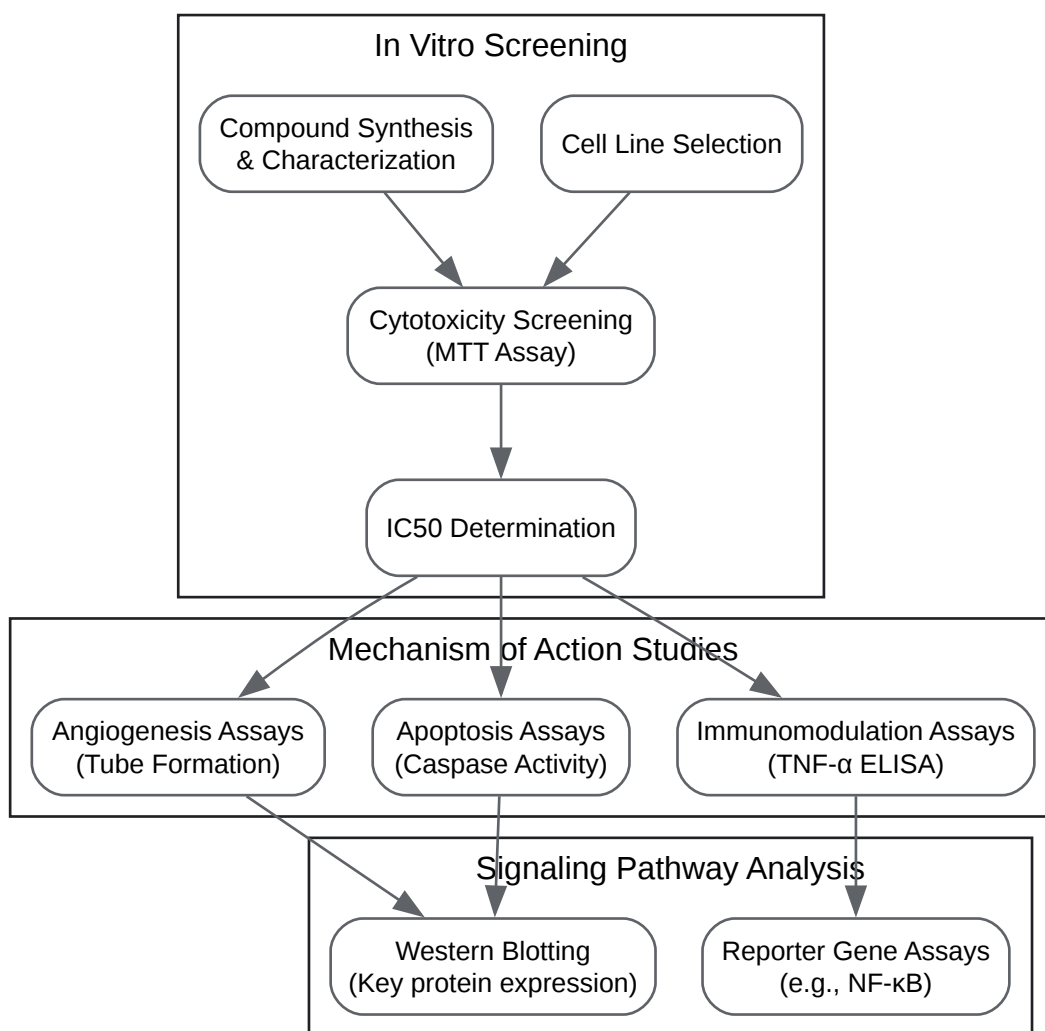

[Click to download full resolution via product page](#)

Caption: General experimental workflow for **3-Azathalidomide** evaluation.

Need Custom Synthesis?

BenchChem offers custom synthesis for rare earth carbides and specific isotopic labeling.

Email: info@benchchem.com or [Request Quote Online](#).

References

- [1. Effects of thalidomide on parameters involved in angiogenesis: an in vitro study - PubMed \[pubmed.ncbi.nlm.nih.gov\]](#)
- [2. Novel thalidomide analogues display anti-angiogenic activity independently of immunomodulatory effects - PMC \[pmc.ncbi.nlm.nih.gov\]](#)
- [3. Design, synthesis, and biological evaluation of new challenging thalidomide analogs as potential anticancer immunomodulatory agents - PubMed \[pubmed.ncbi.nlm.nih.gov\]](#)
- [4. Thalidomide exerts its inhibitory action on tumor necrosis factor alpha by enhancing mRNA degradation - PubMed \[pubmed.ncbi.nlm.nih.gov\]](#)
- [To cite this document: BenchChem. \[Preliminary Research on 3-Azathalidomide Effects: A Technical Guide\]. BenchChem, \[2026\]. \[Online PDF\]. Available at: \[https://www.benchchem.com/product/b3124321/docs#preliminary-research-on-3-azathalidomide-effects-a-technical-guide\]](#)

Disclaimer & Data Validity:

The information provided in this document is for Research Use Only (RUO) and is strictly not intended for diagnostic or therapeutic procedures. While BenchChem strives to provide accurate protocols, we make no warranties, express or implied, regarding the fitness of this product for every specific experimental setup.

Technical Support: The protocols provided are for reference purposes. Unsure if this reagent suits your experiment?

Need Industrial/Bulk Grade? [Request Custom Synthesis Quote](#)

BenchChem

Our mission is to be the trusted global source of essential and advanced chemicals, empowering scientists and researchers to drive progress in science and industry.

Contact

Address: 3281 E Guasti Rd
Ontario, CA 91761, United States
Phone: (601) 213-4426
Email: info@benchchem.com

Contact our Ph.D. Support Team for a compatibility check