

# N-(3-Hydroxyphenyl)Cinnamamide stability problems in solution

**Author:** BenchChem Technical Support Team. **Date:** May 2026

## Compound of Interest

Compound Name: *N*-(3-Hydroxyphenyl)Cinnamamide

CAS No.: 23478-25-3

Cat. No.: B3118234

[Get Quote](#)

## Technical Support Center: N-(3-Hydroxyphenyl)Cinnamamide

A Guide for Researchers, Scientists, and Drug Development Professionals

### Introduction to N-(3-Hydroxyphenyl)Cinnamamide

**N-(3-Hydroxyphenyl)Cinnamamide** is a derivative of cinnamic acid, a compound found in various plants.<sup>[1]</sup> Cinnamic acid and its derivatives are of significant interest in pharmaceutical research due to their potential biological activities, including antioxidant and anticancer properties.<sup>[1][2]</sup> The structure of **N-(3-Hydroxyphenyl)Cinnamamide**, featuring a phenolic hydroxyl group and an amide linkage, makes it susceptible to specific stability challenges in experimental settings. This guide will focus on understanding and mitigating these issues.

### Core Stability Concerns

The primary stability challenges with **N-(3-Hydroxyphenyl)Cinnamamide** in solution stem from two key functional groups: the amide bond and the phenolic hydroxyl group.

- **Amide Bond:** While generally stable, the amide bond can undergo hydrolysis under strong acidic or basic conditions, especially with prolonged heating.[3][4] This stability is crucial for its function in biological systems.[5][6]
- **Phenolic Hydroxyl Group:** The phenol group is susceptible to oxidation, which can be catalyzed by factors such as light, air (oxygen), and the presence of metal ions.[7][8] This can lead to the formation of colored degradation products, primarily quinones.[9]

## Visualizing Potential Degradation Pathways

The following diagram illustrates the primary degradation routes for **N-(3-Hydroxyphenyl)Cinnamamide** in solution.

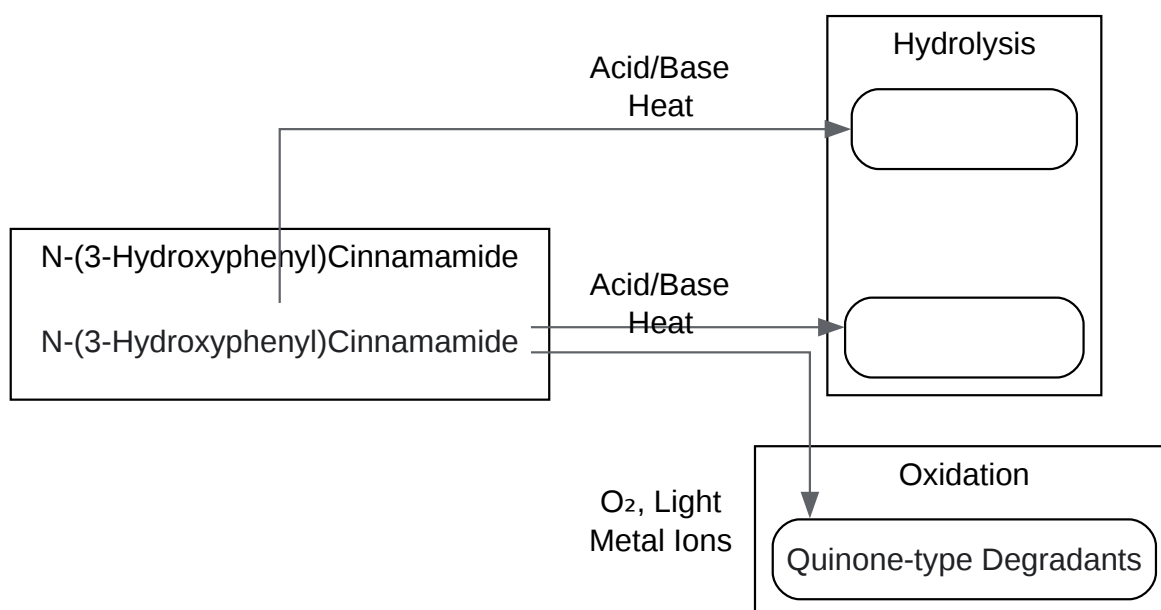

[Click to download full resolution via product page](#)

Caption: Potential degradation pathways for **N-(3-Hydroxyphenyl)Cinnamamide**.

## Troubleshooting Guide: Common Experimental Issues

This section addresses specific problems that researchers may encounter when working with **N-(3-Hydroxyphenyl)Cinnamamide** in solution.

## Issue 1: Solution Discoloration (Yellowing/Browning)

Observation	Probable Cause	Recommended Solution
Freshly prepared solution in aqueous buffer or cell culture media rapidly turns yellow or brown.	Oxidation of the phenolic hydroxyl group. This is often accelerated by exposure to air (oxygen), light, and trace metal ions in the media or buffer.[7] [8]	1. Work in a low-light environment: Protect solutions from direct light by using amber vials or wrapping containers in foil. 2. De-gas solvents: Before dissolving the compound, sparge aqueous buffers and media with an inert gas (e.g., nitrogen or argon) to remove dissolved oxygen. 3. Use fresh, high-purity solvents: Trace metal impurities can catalyze oxidation.[10] 4. Consider antioxidants: For certain applications, the addition of a small amount of an antioxidant like ascorbic acid or butylated hydroxytoluene (BHT) may be beneficial, but this should be tested for compatibility with the experimental system.

## Issue 2: Precipitation or Poor Solubility

Observation	Probable Cause	Recommended Solution
Compound fails to dissolve completely or precipitates out of solution upon standing or dilution.	Low aqueous solubility and/or use of inappropriate solvents. N-(3-Hydroxyphenyl)Cinnamamide is expected to have limited water solubility.[11] The choice of co-solvent and final concentration are critical.	<ol style="list-style-type: none"><li>1. Prepare a concentrated stock solution in an appropriate organic solvent: Dimethyl sulfoxide (DMSO) or ethanol are common choices for initial dissolution.[12] Use fresh, anhydrous DMSO as it can be hygroscopic.[13]</li><li>2. Perform serial dilutions: When preparing working solutions in aqueous media, add the stock solution to the aqueous phase dropwise while vortexing to avoid localized high concentrations that can lead to precipitation.</li><li>3. Consider sonication or gentle warming: These techniques can aid in the dissolution of the compound in the initial stock solution.[13] However, avoid excessive heat to prevent degradation.</li><li>4. Evaluate alternative solvent systems: For in vivo studies, formulations with PEG300, Tween-80, or SBE-<math>\beta</math>-CD may improve solubility.[13]</li></ol>

## Issue 3: Inconsistent or Non-Reproducible Experimental Results

Observation	Probable Cause	Recommended Solution
High variability in bioactivity or analytical measurements between experiments or even within the same experiment.	Compound degradation over time. If solutions are not prepared fresh or are stored improperly, the concentration of the active compound can decrease, leading to inconsistent results.	1. Prepare fresh solutions for each experiment: This is the most reliable way to ensure a consistent concentration of the active compound. 2. Proper storage of stock solutions: If storage is necessary, aliquot stock solutions into single-use vials and store at -20°C or -80°C to minimize freeze-thaw cycles. <sup>[13]</sup> Use within one month when stored at -20°C and within six months at -80°C. <sup>[13]</sup> 3. Analytical verification of concentration: For critical applications, use an analytical technique like HPLC to verify the concentration and purity of the compound in your working solutions, especially if they are stored for any length of time.

## Frequently Asked Questions (FAQs)

Q1: What is the best way to prepare a stock solution of **N-(3-Hydroxyphenyl)Cinnamamide**?

A1: It is recommended to first dissolve the solid compound in a suitable organic solvent such as DMSO or ethanol to create a concentrated stock solution.<sup>[12]</sup> Ensure the solid is fully dissolved, using sonication if necessary, before making further dilutions into aqueous buffers or cell culture media.

Q2: How should I store solid **N-(3-Hydroxyphenyl)Cinnamamide**?

A2: The solid compound should be stored in a tightly sealed container, protected from light and moisture. For long-term storage, refrigeration is recommended.<sup>[14]</sup>

Q3: Can I heat my solution to get the compound to dissolve?

A3: Gentle warming can be used to aid dissolution in the initial stock solution. However, prolonged or excessive heating should be avoided as it can promote hydrolysis of the amide bond.<sup>[3]</sup>

Q4: My cell culture media turns a different color after adding the compound. Is this normal?

A4: A color change, typically to yellow or brown, is an indication of oxidation of the phenol group.<sup>[7]</sup> While this may not always impact the biological activity, it is a sign of degradation. To minimize this, prepare solutions fresh and consider the troubleshooting steps for solution discoloration.

Q5: How can I confirm the stability of my compound in my experimental conditions?

A5: The most definitive way to assess stability is through analytical methods. High-Performance Liquid Chromatography (HPLC) is a common and effective technique for this purpose.<sup>[15][16]</sup> You can analyze your solution at different time points to monitor for any decrease in the parent compound peak and the appearance of degradation product peaks.

## Experimental Protocols

### Protocol 1: Preparation of a 10 mM Stock Solution in DMSO

- Weigh out the required amount of **N-(3-Hydroxyphenyl)Cinnamamide** solid in a sterile microcentrifuge tube.
- Add the appropriate volume of fresh, anhydrous DMSO to achieve a final concentration of 10 mM.
- Vortex the solution until the solid is completely dissolved. If necessary, sonicate for 5-10 minutes in a water bath sonicator.
- Aliquot the stock solution into single-use, light-protected tubes and store at -20°C or -80°C.

## Protocol 2: Workflow for Stability Assessment using HPLC

This workflow provides a general guideline for assessing the stability of **N-(3-Hydroxyphenyl)Cinnamamide** in a specific buffer or medium.

Caption: HPLC workflow for stability assessment.

Methodology:

- Preparation: Prepare a solution of **N-(3-Hydroxyphenyl)Cinnamamide** in your experimental buffer or media at the desired concentration.
- Time Zero (T=0) Sample: Immediately after preparation, take an aliquot of the solution and analyze it by HPLC to determine the initial peak area of the parent compound.
- Incubation: Incubate the remaining solution under your standard experimental conditions (e.g., 37°C, 5% CO<sub>2</sub>).
- Time-Point Sampling: At predetermined time intervals (e.g., 1, 2, 4, 8, 24 hours), withdraw aliquots of the solution for HPLC analysis.
- HPLC Analysis: Analyze each sample using a validated HPLC method. The method should be able to separate the parent compound from potential degradation products.
- Data Analysis: Calculate the percentage of the remaining **N-(3-Hydroxyphenyl)Cinnamamide** at each time point relative to the T=0 sample. Plotting this data will provide a stability profile of the compound under your specific experimental conditions.

## References

- Chemistry Steps. (n.d.). Amides - Structure and Reactivity. Retrieved from [\[Link\]](#)
- Waterman, K. C., & Swanson, J. T. (2022). Oxidation of Drugs during Drug Product Development: Problems and Solutions. *Pharmaceuticals (Basel, Switzerland)*, 15(2), 185. [\[Link\]](#)

- Quora. (2020, November 30). Why do amides require much harsher conditions for hydrolysis than esters? Retrieved from [\[Link\]](#)
- Kumar, A., & Verma, S. (2018). Amide Bond Activation of Biological Molecules. *Molecules* (Basel, Switzerland), 23(12), 3295. [\[Link\]](#)
- Britannica. (2026, January 2). Phenol. Retrieved from [\[Link\]](#)
- Wikipedia. (n.d.). Amide. Retrieved from [\[Link\]](#)
- Wikipedia. (n.d.). Phenols. Retrieved from [\[Link\]](#)
- Singh, Y., Sharma, R., & Singh, G. (2020). Instability of Amide Bond with Trifluoroacetic Acid (20%): Synthesis, Conformational Analysis, and Mechanistic Insights into Cleavable Amide Bond Comprising  $\beta$ -Troponylhydrazino Acid. *ACS Omega*, 5(40), 25969–25977. [\[Link\]](#)
- ResearchGate. (n.d.). Proposed degradation pathways of the drug under different hydrolytic conditions. Retrieved from [\[Link\]](#)
- Roughley, S. D., & Jordan, A. M. (2011). The medicinal chemist's toolbox: an analysis of reactions used in the pursuit of drug candidates. *Journal of Medicinal Chemistry*, 54(10), 3451–3479. [\[Link\]](#)
- Al-Rimawi, F. (2014). Development and validation of an HPLC method for the determination of phenol and its related impurities in a pharmaceutical formulation. *Journal of Taibah University for Science*, 8(3), 235-240. [\[Link\]](#)
- Chemistry LibreTexts. (2024, March 17). 17.10: Reactions of Phenols. Retrieved from [\[Link\]](#)
- Thermo Fisher Scientific. (2025, September 12). SAFETY DATA SHEET. Retrieved from [\[Link\]](#)
- Springer Nature Experiments. (n.d.). Extraction and Isolation of Phenolic Compounds. Retrieved from [\[Link\]](#)
- Lee, J. H., Shin, D. H., & Kim, Y. J. (2019). N-Phenyl Cinnamamide Derivatives Protect Hepatocytes against Oxidative Stress by Inducing Cellular Glutathione Synthesis via Nuclear

Factor (Erythroid-Derived 2)-Like 2 Activation. *Molecules* (Basel, Switzerland), 24(18), 3328.

[\[Link\]](#)

- Zhang, L., Wang, M., & Liu, R. H. (2022). Extraction and characterization of phenolic compounds and their potential antioxidant activities. *Critical Reviews in Food Science and Nutrition*, 62(21), 5763–5780. [\[Link\]](#)
- Naczek, M., & Shahidi, F. (2004). Extraction and analysis of phenolics in food. *Journal of Chromatography A*, 1054(1-2), 95–111. [\[Link\]](#)
- Al-Owaisi, M., Al-Hadi, A. A., & Weli, A. M. (2014). Optimization Method for Phenolic Compounds Extraction from Medicinal Plant (*Juniperus procera*) and Phytochemicals Screening. *Pharmacognosy Research*, 6(4), 292–297. [\[Link\]](#)
- MDPI. (n.d.). N-Phenyl Cinnamamide Derivatives Protect Hepatocytes against Oxidative Stress by Inducing Cellular Glutathione Synthesis via Nuclear Factor (Erythroid-Derived 2)-Like 2 Activation. Retrieved from [\[Link\]](#)
- Monisha, R., & Krishnan, M. (2018). Degradation of cinnamic acid by a newly isolated bacterium *Stenotrophomonas* sp. TRMK2. *Biocatalysis and Agricultural Biotechnology*, 13, 118-124. [\[Link\]](#)
- MDPI. (2019, November 15). Synthesis, Characterization, and Crystal Structure of N-(3-nitrophenyl)cinnamamide. Retrieved from [\[Link\]](#)
- Universitas Hasanuddin. (2022, March 11). Development trans-N-benzyl hydroxyl cinnamamide based compounds from cinnamic acids and characteristics anticancer potency. Retrieved from [\[Link\]](#)
- ResearchGate. (2024, December 9). (PDF) Polymorphism in N-(3-Hydroxyphenyl)-3-methoxybenzamide. Retrieved from [\[Link\]](#)
- MDPI. (2024, December 12). Polymorphism in N-(3-Hydroxyphenyl)-3-methoxybenzamide. Retrieved from [\[Link\]](#)
- MDPI. (2019, November 15). Synthesis, Characterization, and Crystal Structure of N-(3-nitrophenyl)cinnamamide. Retrieved from [\[Link\]](#)

- Sultan Qaboos University Journal For Science. (n.d.). Development and Validation of an RP-HPLC- FLD Method for the Determination of Biogenic Amines after Pre-column Derivatization with. Retrieved from [\[Link\]](#)
- Springer. (n.d.). Advancements in HPLC Techniques for Detecting and identification of Process-Related and Degradants Impurities in Pharmaceutical Compounds. Retrieved from [\[Link\]](#)
- ResearchGate. (n.d.). Development and Validation of HPLC Method for Simultaneous Determination of Three Constituent in 4-FDC Tablet by Pre-Column Derivatization. Retrieved from [\[Link\]](#)
- National Center for Biotechnology Information. (n.d.). Recent advances in synthetic approaches for bioactive cinnamic acid derivatives. Retrieved from [\[Link\]](#)
- ResearchGate. (2025, August 9). (PDF) A HPLC Method for the Quantitative Determination of N-(2-hydroxy-5-nitrophenylcarbamothioyl)-3,5-imethylbenzamide in Biological Samples. Retrieved from [\[Link\]](#)
- PubMed. (2024, June 6). Discovery of (E)-3-(4-chlorophenyl)-N-(5-hydroxypentyl)acrylamide among N-substituted cinnamamide derivatives as a novel cosmetic ingredient for hyperpigmentation. Retrieved from [\[Link\]](#)
- Pradeep Research Group. (2012, January 12). Understanding the Degradation Pathway of the Pesticide, Chlorpyrifos by Noble Metal Nanoparticles. Retrieved from [\[Link\]](#)
- ResearchGate. (n.d.). HPLC METHOD FOR IDENTIFICATION AND QUANTIFICATION OF THREE ACTIVE SUBSTANCES IN A DERMATOLOGICAL PREPARATION ñ VIOSEPT OINTMENT. Retrieved from [\[Link\]](#)
- National Center for Biotechnology Information. (2012, July 27). Synthesis, Chemical and Enzymatic Hydrolysis, and Aqueous Solubility of Amino Acid Ester Prodrugs of 3-Carboranyl Thymidine Analogues for Boron Neutron Capture Therapy of Brain Tumors. Retrieved from [\[Link\]](#)
- ResearchGate. (n.d.). Discovery of (E)-3-(4-chlorophenyl)-N-(5-hydroxypentyl)acrylamide among N-substituted cinnamamide derivatives as a novel cosmetic ingredient for

hyperpigmentation. Retrieved from [[Link](#)]

### Need Custom Synthesis?

BenchChem offers custom synthesis for rare earth carbides and specific isotopic labeling.

Email: [info@benchchem.com](mailto:info@benchchem.com) or [Request Quote Online](#).

## Sources

- [1. mdpi.com](https://www.mdpi.com) [[mdpi.com](https://www.mdpi.com)]
- [2. pakdosen.unhas.ac.id](https://pakdosen.unhas.ac.id) [[pakdosen.unhas.ac.id](https://pakdosen.unhas.ac.id)]
- [3. Amide - Wikipedia](https://en.wikipedia.org) [[en.wikipedia.org](https://en.wikipedia.org)]
- [4. pubs.acs.org](https://pubs.acs.org) [[pubs.acs.org](https://pubs.acs.org)]
- [5. Amides - Structure and Reactivity - Chemistry Steps](https://chemistrysteps.com) [[chemistrysteps.com](https://chemistrysteps.com)]
- [6. Amide Bond Activation of Biological Molecules - PMC](https://pubmed.ncbi.nlm.nih.gov) [[pubmed.ncbi.nlm.nih.gov](https://pubmed.ncbi.nlm.nih.gov)]
- [7. Phenol | Definition, Structure, Uses, & Facts | Britannica](https://www.britannica.com) [[britannica.com](https://www.britannica.com)]
- [8. Phenols - Wikipedia](https://en.wikipedia.org) [[en.wikipedia.org](https://en.wikipedia.org)]
- [9. chem.libretexts.org](https://chem.libretexts.org) [[chem.libretexts.org](https://chem.libretexts.org)]
- [10. Oxidation of Drugs during Drug Product Development: Problems and Solutions - PMC](https://pubmed.ncbi.nlm.nih.gov) [[pubmed.ncbi.nlm.nih.gov](https://pubmed.ncbi.nlm.nih.gov)]
- [11. Buy Cinnamamide, p-hydroxy-N-\(p-hydroxyphenethyl\)- | 20375-37-5](https://www.smolecule.com) [[smolecule.com](https://www.smolecule.com)]
- [12. caymanchem.com](https://www.caymanchem.com) [[caymanchem.com](https://www.caymanchem.com)]
- [13. medchemexpress.com](https://www.medchemexpress.com) [[medchemexpress.com](https://www.medchemexpress.com)]
- [14. WERCS Studio - Application Error](https://assets.thermofisher.com) [[assets.thermofisher.com](https://assets.thermofisher.com)]
- [15. researchgate.net](https://www.researchgate.net) [[researchgate.net](https://www.researchgate.net)]
- [16. mdpi.com](https://www.mdpi.com) [[mdpi.com](https://www.mdpi.com)]
- To cite this document: BenchChem. [N-(3-Hydroxyphenyl)Cinnamamide stability problems in solution]. BenchChem, [2026]. [Online PDF]. Available at: [<https://www.benchchem.com/product/b3118234/docs#n-3-hydroxyphenyl-cinnamamide-stability-problems-in-solution>]

**Disclaimer & Data Validity:**

The information provided in this document is for Research Use Only (RUO) and is strictly not intended for diagnostic or therapeutic procedures. While BenchChem strives to provide accurate protocols, we make no warranties, express or implied, regarding the fitness of this product for every specific experimental setup.

**Technical Support:** The protocols provided are for reference purposes. Unsure if this reagent suits your experiment?

**Need Industrial/Bulk Grade?** [Request Custom Synthesis Quote](#)

## BenchChem

Our mission is to be the trusted global source of essential and advanced chemicals, empowering scientists and researchers to drive progress in science and industry.

### Contact

Address: 3281 E Guasti Rd  
Ontario, CA 91761, United States  
Phone: (601) 213-4426  
Email: [info@benchchem.com](mailto:info@benchchem.com)

[Contact our Ph.D. Support Team for a compatibility check](#)