

Difference between cis and trans 4-hydroxyproline methyl esters

Author: BenchChem Technical Support Team. **Date:** April 2026

Compound of Interest

Compound Name: *Methyl 4-hydroxyproline-2-carboxylate*

CAS No.: *217184-95-7*

Cat. No.: *B3116521*

[Get Quote](#)

Technical Guide: cis- vs. trans-4-Hydroxyproline Methyl Esters

Executive Summary

The stereochemical distinction between cis- and trans-4-hydroxyproline methyl esters is not merely a matter of nomenclature; it dictates the molecule's ring puckering preference (

-endo vs.

-exo), which fundamentally alters its reactivity, spectroscopic signature, and utility in peptidomimetic drug design. This guide provides a definitive analysis for researchers synthesizing collagen mimetics or designing conformationally constrained pharmacophores.

Structural & Stereochemical Analysis[1]

The core difference lies in the relative stereochemistry at the C4 position relative to the C2 carboxylate group.

Nomenclature and Configuration

- Natural Isomer: trans-4-hydroxy-L-proline methyl ester.[\[1\]](#)[\[2\]](#)[\[3\]](#)[\[4\]](#)
 - IUPAC: Methyl (2S,4R)-4-hydroxypyrrolidine-2-carboxylate.[\[3\]](#)[\[5\]](#)
 - Stereochemistry: The hydroxyl group at C4 is trans to the carboxylate at C2.
- Unnatural Isomer: cis-4-hydroxy-L-proline methyl ester (L-allo).
 - IUPAC: Methyl (2S,4S)-4-hydroxypyrrolidine-2-carboxylate.[\[3\]](#)[\[5\]](#)
 - Stereochemistry: The hydroxyl group at C4 is cis to the carboxylate at C2.

Conformational Puckering (-exo vs. -endo)

The pyrrolidine ring is not planar. The electronegativity of the hydroxyl group drives a specific "pucker" via the gauche effect, where the

orbital donates electron density into the

antibonding orbital.

- The trans (4R) Effect: The electronegative OH group prefers a pseudo-axial orientation to maximize the gauche effect with the ring nitrogen. This forces the ring into a -exo pucker (C4 is displaced up toward the carboxylate face). This conformation preorganizes the backbone torsion angles () to match those found in the collagen triple helix.
- The cis (4S) Effect: In the cis isomer, the gauche effect favors the -endo pucker (C4 is displaced down, away from the carboxylate).
 - Critical Feature: In non-polar solvents (e.g., CHCl₃), the cis isomer is stabilized by a transannular hydrogen bond between the C4-hydroxyl proton and the C2-ester carbonyl oxygen. This interaction is geometrically impossible in the trans isomer.

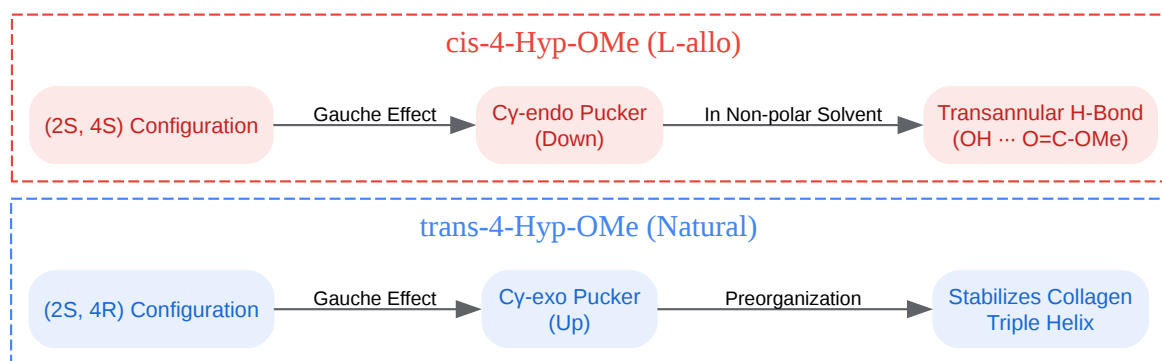

[Click to download full resolution via product page](#)

Figure 1: Conformational consequences of C4 stereochemistry. The 4R isomer adopts the Cy-exo pucker essential for collagen stability, while the 4S isomer favors Cy-endo.

Synthetic Protocols

Synthesis of trans-4-Hydroxyproline Methyl Ester

This reaction retains the natural stereochemistry. The use of thionyl chloride generates anhydrous HCl in situ, catalyzing the esterification while preventing racemization at the

-center.

Protocol:

- Suspend (2S,4R)-4-hydroxyproline (10.0 g, 76.3 mmol) in dry methanol (100 mL) at 0 °C.
- Dropwise add thionyl chloride (SOCl₂), 1.2 eq) over 30 minutes. Caution: Exothermic gas evolution.
- Heat to reflux for 4–6 hours. Monitor by TLC (n-BuOH:AcOH:H₂O 4:1:1).
- Concentrate in vacuo.

- Recrystallize the resulting hydrochloride salt from MeOH/Et

O.

- Yield: >95%
- Product: White crystalline solid (HCl salt).

Synthesis of cis-4-Hydroxyproline Methyl Ester (via Mitsunobu Inversion)

Direct esterification of cis-Hyp is expensive due to the cost of the starting material. The standard industrial route is the Mitsunobu inversion of the N-protected trans isomer.

Protocol:

- Protection: Start with N-Boc-trans-4-Hyp-OMe.
- Mitsunobu Reaction:
 - Dissolve N-Boc-trans-Hyp-OMe (1.0 eq), Triphenylphosphine (PPh₃, 1.2 eq), and 4-Nitrobenzoic acid (1.2 eq) in anhydrous THF.
 - Cool to 0 °C. Add Diisopropyl azodicarboxylate (DIAD, 1.2 eq) dropwise.
 - Stir at RT for 12–16 h. (Inversion of configuration occurs at C4).
- Hydrolysis:
 - Treat the intermediate (4S)-4-nitrobenzoate ester with LiOH or NaNH₂/MeOH (mild methanolysis) to remove the benzoyl group.
- Deprotection (Optional): Remove Boc with HCl/Dioxane if the free amine is required.

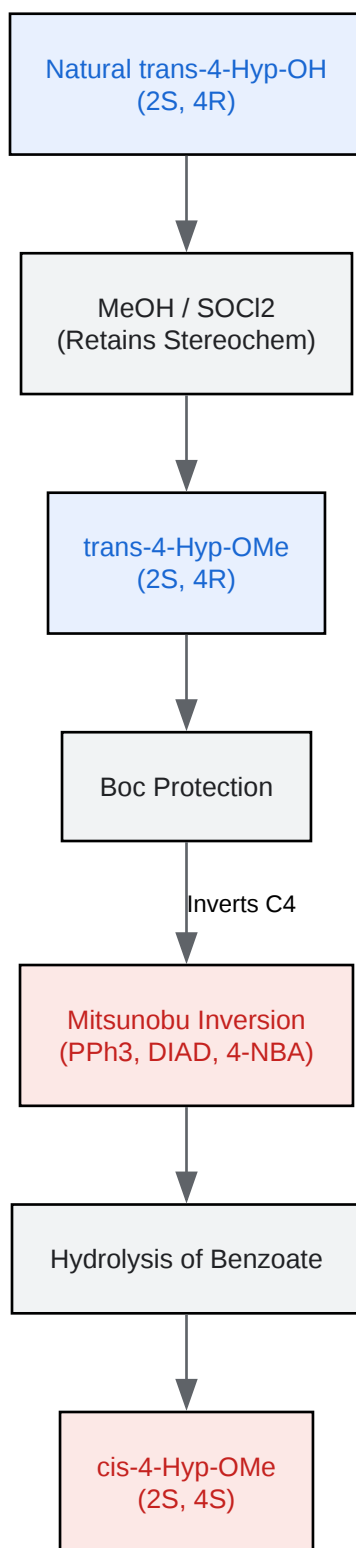

[Click to download full resolution via product page](#)

Figure 2: Synthetic workflow. Accessing the cis-isomer typically requires stereochemical inversion via the Mitsunobu reaction.

Analytical Differentiation (Data & Logic)

Distinguishing these isomers requires careful analysis of physical properties and NMR parameters.

Physical Properties Comparison

Property	trans-Isomer (Natural)	cis-Isomer (L-allo)
Configuration	(2S, 4R)	(2S, 4S)
MP (HCl Salt)	152–164 °C (Solid)	Often lower MP or oil (as free base)
Optical Rotation	to (H O)	Distinct (solvent dependent)
Solubility	High in H O, MeOH	Soluble in organic solvents (if N-protected)

NMR Spectroscopy (¹H NMR)

The most definitive method for identification is Proton NMR. The coupling constants (

) and chemical shifts (

) reflect the ring pucker.

- Coupling Constants (

): The Karplus relationship dictates that the dihedral angles in the

-exo (trans) vs.

-endo (cis) conformers produce distinct splitting patterns for the H4 proton.

- Chemical Shift (

):

- In CDCl₃

(for N-protected esters), the cis-isomer's OH proton appears significantly downfield (often >3.5 ppm) and is less concentration-dependent due to the intramolecular H-bond to the ester carbonyl.

- The trans-isomer's OH proton is typically upfield or broad due to intermolecular exchange.

NMR Feature	trans-4-Hyp-OMe	cis-4-Hyp-OMe
H4 Multiplicity	Typically a tt or distinct multiplet	Distinct multiplet (often broader)
H4 Shift	ppm	ppm (Shift varies by substituent)
OH Signal (CDCl ₃)	Broad/Upfield (Intermolecular H-bond)	Sharp/Downfield (Intramolecular H-bond to C=O)
¹³ C Shift (ppm)	ppm	ppm

Expert Tip: To rapidly distinguish the two in a crude mixture (e.g., after a Mitsunobu reaction), look for the OH peak in d₆-DMSO. The distinct environments often result in a clear separation of the hydroxyl proton signals.

References

- National Center for Biotechnology Information. PubChem Compound Summary for CID 11435319, 4-Hydroxy-L-proline methyl ester hydrochloride. PubChem.[5] Available at: [\[Link\]](#)
- Raines, R. T., et al. The Aberrance of the 4S Diastereomer of 4-Hydroxyproline. Journal of the American Chemical Society (via NCBI PMC). Available at: [\[Link\]](#)

- ConnectSci.Studies on the Synthesis of cis-4-Hydroxy-L-proline. Australian Journal of Chemistry. Available at: [\[Link\]](#)

Need Custom Synthesis?

BenchChem offers custom synthesis for rare earth carbides and specific isotopic labeling.

Email: info@benchchem.com or [Request Quote Online](#).

Sources

- [1. spectrabase.com \[spectrabase.com\]](https://spectrabase.com)
- [2. N-Boc-trans-4-Hydroxy-L-proline methyl ester | 74844-91-0 \[chemicalbook.com\]](https://chemicalbook.com)
- [3. 40216-83-9 trans-4-Hydroxy-L-proline methyl ester hydrochloride AKSci J99390 \[aksci.com\]](https://aksci.com)
- [4. researchgate.net \[researchgate.net\]](https://researchgate.net)
- [5. 4-Hydroxy-L-proline methyl ester hydrochloride | C6H12ClNO3 | CID 11435319 - PubChem \[pubchem.ncbi.nlm.nih.gov\]](https://pubchem.ncbi.nlm.nih.gov)
- To cite this document: BenchChem. [Difference between cis and trans 4-hydroxyproline methyl esters]. BenchChem, [2026]. [Online PDF]. Available at: [\[https://www.benchchem.com/product/b3116521/docs#difference-between-cis-and-trans-4-hydroxyproline-methyl-esters\]](https://www.benchchem.com/product/b3116521/docs#difference-between-cis-and-trans-4-hydroxyproline-methyl-esters)

Disclaimer & Data Validity:

The information provided in this document is for Research Use Only (RUO) and is strictly not intended for diagnostic or therapeutic procedures. While BenchChem strives to provide accurate protocols, we make no warranties, express or implied, regarding the fitness of this product for every specific experimental setup.

Technical Support: The protocols provided are for reference purposes. Unsure if this reagent suits your experiment?

Need Industrial/Bulk Grade? [Request Custom Synthesis Quote](#)

BenchChem

Our mission is to be the trusted global source of essential and advanced chemicals, empowering scientists and researchers to drive progress in science and industry.

Contact

Address: 3281 E Guasti Rd

Ontario, CA 91761, United States

Phone: (601) 213-4426

Email: info@benchchem.com

[Contact our Ph.D. Support Team for a compatibility check](#)