

Technical Support Center: BCP C-H Functionalization

Author: BenchChem Technical Support Team. **Date:** April 2026

Compound of Interest

Compound Name: *Bicyclo[1.1.1]pentan-1-ylmethanamine hydrochloride*

CAS No.: 2108646-79-1

Cat. No.: B3115701

[Get Quote](#)

Status: Operational | Tier: Level 3 (Advanced Research Support) Topic: Overcoming Challenges in Bicyclo[1.1.1]pentane (BCP) C-H Functionalization

Introduction: The "Escape from Flatland" Initiative

Welcome to the BCP Technical Support Center. You are likely here because you are attempting to replace a phenyl ring or tert-butyl group with a BCP moiety to improve solubility, metabolic stability, or patentability—a strategy known as "escaping from flatland."

The Core Problem: While BCPs are excellent bioisosteres, they are thermodynamically frustrated systems. With a strain energy of ~68 kcal/mol, the BCP core is prone to fragmentation. Furthermore, the chemical distinction between the Bridgehead (C1/C3) and the Bridge (C2) positions creates a dichotomy in reactivity that often leads to failed experiments.

This guide is structured to troubleshoot these specific reactivity profiles.

Module 1: Bridgehead (C1/C3) Functionalization

Status: Well-Established but Finicky

The C1/C3 positions are the most common entry points. The C-H bonds here are tertiary but possess high

-character (approx. 30%), making them relatively acidic (

~39) yet paradoxically difficult to engage in standard radical chemistry without cage fragmentation.

Protocol A: Photocatalytic HAT (Hydrogen Atom Transfer)

Recommended System: Tetrabutylammonium decatungstate (TBADT) / 365-390 nm LED.

The Issue: "I'm getting low yields and a complex mixture of oligomers."

Root Cause Analysis:

- Polysubstitution: The BCP product is often more electron-rich or sterically accessible than the starting material, leading to double functionalization.
- Oxygen Quenching: BCP radicals are short-lived; traces of oxygen can intercept the radical chain.
- Solvent Effects: Using H-atom donor solvents (like THF) competes with the BCP substrate.

Troubleshooting Steps:

Parameter	Recommendation	The "Why" (Mechanism)
Catalyst Loading	0.5 - 2 mol% TBADT	TBADT* is an aggressive H-abstractor. High loading promotes side reactions.
Solvent	Acetonitrile (MeCN)	MeCN is polar enough to solubilize TBADT but has a high BDE (93 kcal/mol), preventing solvent activation.
Stoichiometry	BCP (3-5 equiv.)	Using excess BCP statistically favors mono-functionalization over di-functionalization.
Light Source	390 nm (Violet)	While TBADT absorbs at 365 nm, 390 nm reduces background degradation of sensitive substrates.

Visual Workflow: TBADT Cycle

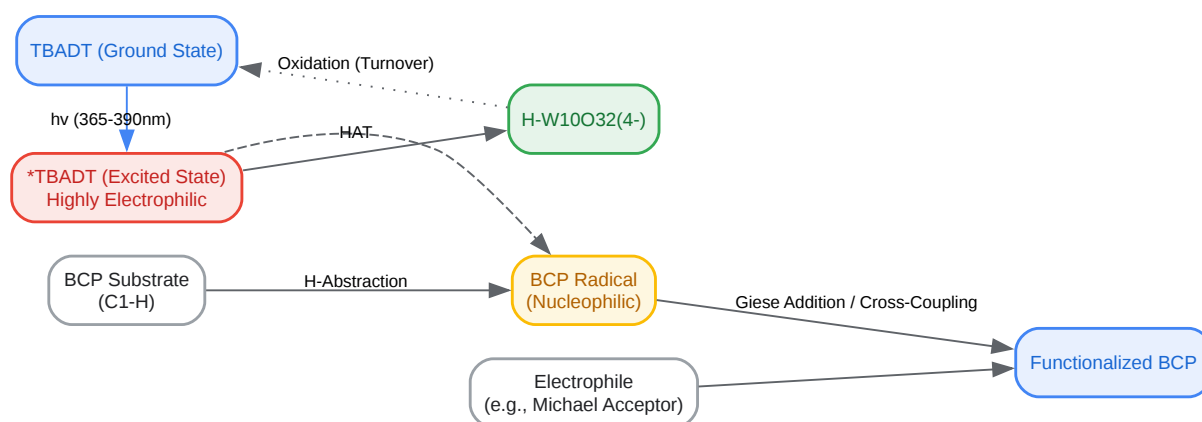

[Click to download full resolution via product page](#)

Caption: The photocatalytic cycle of TBADT mediated C-H functionalization. Note the electrophilic nature of the excited state targeting the hydridic C1-H bond.[1]

Protocol B: Carbene Insertion (Enantioselective)

Recommended System: Rhodium(II) catalysis (e.g.,

).

The Issue: "The reaction works, but I see significant ring opening to [1.1.0]bicyclobutanes."

Corrective Action:

- Temperature Control: Maintain reaction temperature between -40°C and 0°C. Higher temperatures favor the strain-release rearrangement.
- Carbene Source: Use Donor/Acceptor diazo compounds.[2] The "donor" group stabilizes the carbene intermediate, taming its reactivity to prevent non-selective insertion or fragmentation.

Module 2: Bridge (C2) Functionalization

Status: Experimental / High Difficulty

This is the "Holy Grail." The C2-H bonds are secondary, sterically shielded by the bridgehead hydrogens, and have a higher Bond Dissociation Energy (BDE) than C1-H.

The Issue: "I applied C1 conditions (TBADT), but I only got C1 product. How do I hit C2?"

Answer: You cannot use standard HAT conditions for C2. The C1 position is kinetically and thermodynamically favored for radical abstraction. You must use Directing Groups or De Novo Synthesis.

Decision Matrix: How to access C2-substituted BCPs

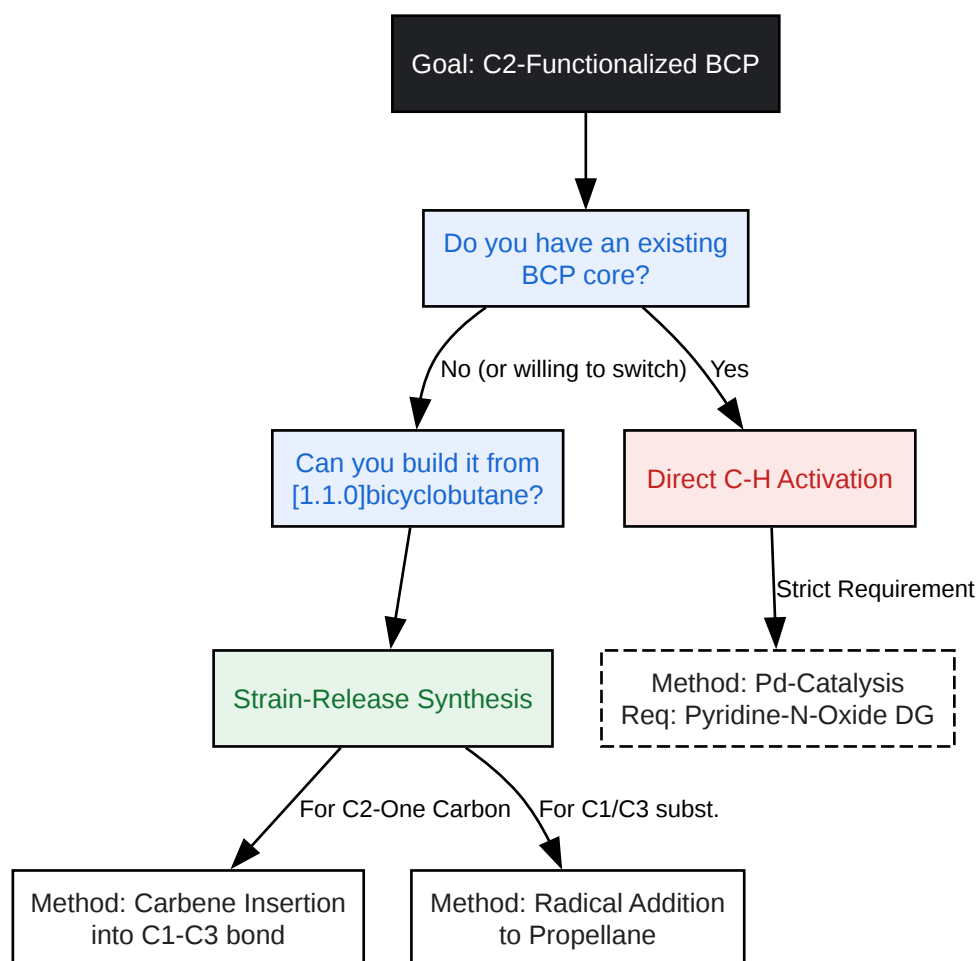

[Click to download full resolution via product page](#)

Caption: Decision tree for accessing C2-substituted BCPs. Direct functionalization is restricted to specific directing groups (DG).

Protocol C: Directed C2-H Activation (Palladium)

Reference: See Mykhailiuk or Knochel methodologies.

- Directing Group (DG): You must install a Pyridine-N-Oxide or a bidentate amide at the C1 position.
 - Mechanism:^{[1][3][4][5][6]} The DG coordinates Pd(II), placing the metal in proximity to the C2-H bond, overcoming the inherent preference for C1.
- Conditions:

, Ag salts (oxidant), and heating (often 80-100°C).

- Warning: This often requires a pre-installed carboxylic acid at C1 to attach the DG.

Protocol D: The "Linchpin" Strategy (De Novo)

If direct functionalization fails, switch to [1.1.0]bicyclobutane (BCB) insertion.

- Reaction: Triplet carbene insertion into the central bond of BCB.[7]
- Result: This installs a functional group at C2 while forming the BCP cage. This is often higher yielding than trying to functionalize an inert BCP C2-H bond.

Module 3: Handling & Purification

Status: Practical Lab Safety

The Issue: "My NMR looks great, but after rotavap, the flask is empty."

Fact: Simple BCPs (e.g., phenyl-BCP) are highly volatile. BCP itself sublimes easily.

Operational Guidelines:

Step	Protocol
Solvent Removal	Do NOT use high vacuum. Use a rotavap at >100 mbar and <30°C bath temperature.
Solvent Choice	Use Pentane/Ether for extractions. They can be distilled off at low temperatures.
Storage	Store as a solid salt (if amine/acid) or in solution at -20°C.
TLC Visualization	BCPs are often UV-inactive. Use KMnO ₄ (stains alkenes/oxidizable C-H) or Iodine chamber.

FAQ: Frequently Asked Questions

Q1: Can I use standard peroxide initiators (DCP, TBP) for BCP functionalization?

- A: Generally, No. Thermal radical initiators often require temperatures (>80°C) that induce ring opening of the BCP radical into a flexible chain or polymerization. Photochemical methods (Room Temp) are superior for cage integrity.

Q2: Why is my BCP product unstable on silica gel?

- A: BCPs with electron-donating groups can undergo acid-catalyzed rearrangement to cyclobutanes or dienes.
- Fix: Pre-treat your silica column with 1% Triethylamine to neutralize acidity, or use Alumina (Neutral).

Q3: Is BCP actually a good phenyl bioisostere?

- A: Yes, but with caveats. It matches the vector (180° substitution) but not the electronics (no pi-stacking). It is best used to improve solubility (logP reduction) rather than to engage in active site binding.

References

- Bioisosterism & Properties
 - Stepan, A. F., et al. "Application of the Bicyclo[1.1.1]pentane Motif as a Nonclassical Phenyl Ring Bioisostere in the Design of a Potent and Orally Active γ -Secretase Inhibitor." [8] Journal of Medicinal Chemistry, 2012. [Link](#)
- Photocatalytic C-H Functionalization (TBADT)
 - Bonnet, L., et al. "Photocatalytic Alkylation of Amides, Ethers, and Acetals." Chemical Reviews, 2016 (Review of TBADT chemistry). [Link](#)
 - Note on BCP specific: See recent works by the Fagnou or MacMillan groups on H
- Carbene Insertion (Rh-Catalysis)
 - Turberg, M., et al. "Enantioselective Functionalization of Bicyclo[1.1.1]pentanes." Nature, 2020. [Link](#)

- C2-Functionalization (Direct & De Novo)
 - Ma, X., et al. "Direct C2-Functionalization of Bicyclo[1.1.1]pentanes." Journal of the American Chemical Society, 2021. [Link](#)
 - Walsh, P. J., et al. "Tricyclo[1.1.1.0]pentane (Propellane) Chemistry." Chemical Reviews, 2021.[9] [Link](#)

Need Custom Synthesis?

BenchChem offers custom synthesis for rare earth carbides and specific isotopic labeling.

Email: info@benchchem.com or [Request Quote Online](#).

Sources

- 1. C–C bond formation via photocatalytic direct functionalization of simple alkanes - PMC [[pmc.ncbi.nlm.nih.gov](https://pubmed.ncbi.nlm.nih.gov/)]
- 2. communities.springernature.com [communities.springernature.com]
- 3. [researchgate.net](https://www.researchgate.net) [[researchgate.net](https://www.researchgate.net)]
- 4. Conquering the Synthesis and Functionalization of Bicyclo[1.1.1]pentanes - PMC [[pmc.ncbi.nlm.nih.gov](https://pubmed.ncbi.nlm.nih.gov/)]
- 5. Tungstate Photocatalyst | Chem-Station Int. Ed. [[en.chem-station.com](https://www.chem-station.com/en)]
- 6. Application of Bicyclo[1.1.1]pentane in Drug Development Research [[bldpharm.com](https://www.bldpharm.com)]
- 7. Triplet Carbene Insertion Enables Modular Access to C2-Substituted Bicyclo[1.1.1]pentanes - PubMed [pubmed.ncbi.nlm.nih.gov]
- 8. [semanticscholar.org](https://www.semanticscholar.org) [[semanticscholar.org](https://www.semanticscholar.org)]
- 9. Bridge Functionalisation of Bicyclo[1.1.1]pentane Derivatives - PMC [[pmc.ncbi.nlm.nih.gov](https://pubmed.ncbi.nlm.nih.gov/)]
- To cite this document: BenchChem. [Technical Support Center: BCP C-H Functionalization]. BenchChem, [2026]. [Online PDF]. Available at: [<https://www.benchchem.com/product/b3115701/docs#technical-support-center-bcp-c-h-functionalization>]

Disclaimer & Data Validity:

The information provided in this document is for Research Use Only (RUO) and is strictly not intended for diagnostic or therapeutic procedures. While BenchChem strives to provide accurate protocols, we make no warranties, express or implied, regarding the fitness of this product for every specific experimental setup.

Technical Support: The protocols provided are for reference purposes. Unsure if this reagent suits your experiment?

Need Industrial/Bulk Grade? [Request Custom Synthesis Quote](#)

BenchChem

Our mission is to be the trusted global source of essential and advanced chemicals, empowering scientists and researchers to drive progress in science and industry.

Contact

Address: 3281 E Guasti Rd
Ontario, CA 91761, United States
Phone: (601) 213-4426
Email: info@benchchem.com

[Contact our Ph.D. Support Team for a compatibility check](#)