

Technical Support Center: BCP Amine Synthesis & Optimization

Author: BenchChem Technical Support Team. **Date:** April 2026

Compound of Interest

Compound Name: *Bicyclo[1.1.1]pentan-1-ylmethanamine hydrochloride*

CAS No.: 2108646-79-1

Cat. No.: B3115701

[Get Quote](#)

Status: Active Operator: Senior Application Scientist Subject: Troubleshooting Side Reactions in Bicyclo[1.1.1]pentan-1-amine Synthesis

Introduction: The BCP Challenge

Welcome to the technical support hub for Bicyclo[1.1.1]pentane (BCP) synthesis. You are likely here because BCP amines—valuable bioisosteres for para-substituted anilines and tert-butyl groups—are notoriously difficult to synthesize cleanly.

The high strain energy of the [1.1.1]propellane precursor (~68 kcal/mol) drives reactivity but also fuels rapid, uncontrolled side pathways. Whether you are employing strain-release amination or Curtius rearrangement, this guide addresses the specific failure modes (polymerization, ring fragmentation, and rearrangements) that compromise your yields.

Module 1: Strain-Release Amination of [1.1.1]Propellane

Context: This route involves the addition of N-nucleophiles (ionic) or N-centered radicals to the central bond of [1.1.1]propellane.^[1]

Visualizing the Failure Modes

The following diagram illustrates the kinetic competition between productive amination and the dreaded "staffane" polymerization.

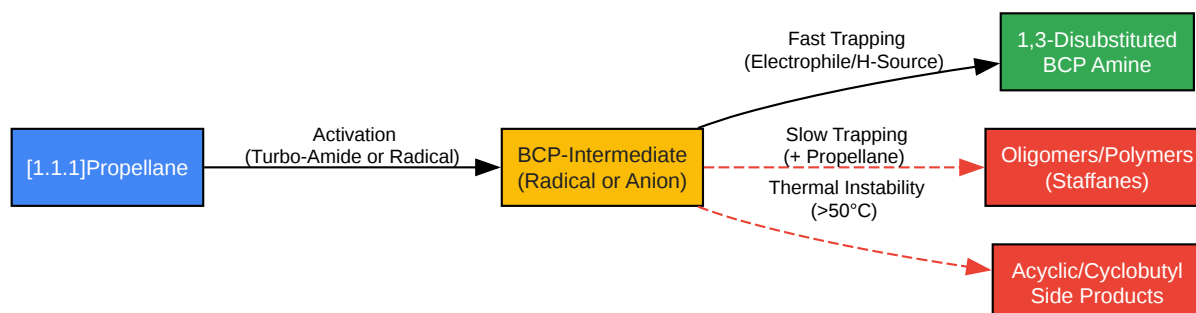

Figure 1: Kinetic competition in propellane amination. Slow trapping leads to oligomerization.

[Click to download full resolution via product page](#)

Troubleshooting Guide: Ionic & Radical Addition

Q1: I am using "Turbo-Amides" (e.g., $\text{TMPMgCl}\cdot\text{LiCl}$) for direct amination, but I see low conversion and significant protonated byproduct (monosubstituted BCP).

- **Diagnosis: Moisture Sensitivity & Protonation.** The BCP-magnesium intermediate formed after amide addition is a potent base. Even trace moisture in your electrophile (e.g., alkyl halide) or solvent will quench the anion immediately, yielding the monosubstituted BCP-amine rather than the desired 1,3-disubstituted product.
- **The Fix:**
 - **Titrate your Grignard:** Ensure your Turbo-Grignard is active.
 - **Temperature Control:** Perform the addition at 0 °C to 22 °C. Do not heat above 50 °C during the metallation step; BCP anions are thermally sensitive and can undergo ring fragmentation.
 - **Deuterium Check:** Run a pilot reaction quenched with D_2O . If you see <90% D-incorporation at the bridgehead, your system is wet or the anion is decomposing.

Q2: During radical amination (photoredox or Fe-catalyzed), my reaction mixture turns into a white suspension/gel, and yield is <20%.

- **Diagnosis: Staffane Polymerization.** You are observing the formation of [n]staffanes (oligomers of BCP). This occurs when the propagation rate (radical adding to another propellane molecule) exceeds the rate of radical trapping (radical reacting with the desired terminator).
- **The Fix:**
 - **Increase Trapping Agent Concentration:** If using a radical trap (e.g., heteroaryl chloride, diazo compound), increase its equivalents (1.5x – 2.0x).
 - **Dilution:** High concentration favors intermolecular polymerization. Run the reaction more dilute (0.05 M – 0.1 M).
 - **Slow Addition:** Add the [1.1.1]propellane solution slowly via syringe pump to maintain a low steady-state concentration relative to the radical precursor.

Module 2: The Curtius Rearrangement Route

Context: Converting BCP-carboxylic acids to amines via acyl azides. This is preferred for scale-up but prone to specific side reactions due to the bulky BCP cage.

Visualizing the Rearrangement Pathways

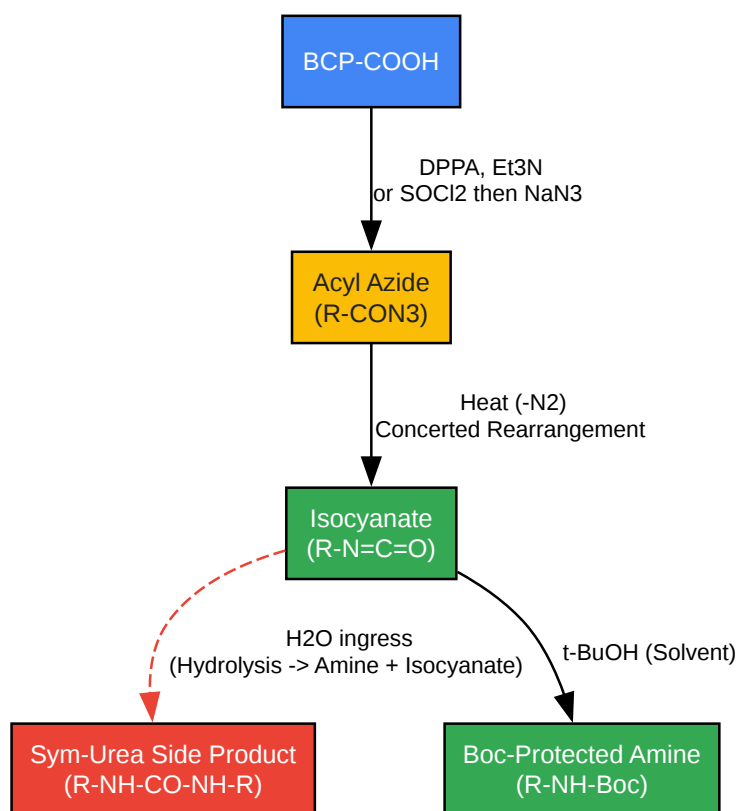

Figure 2: Curtius Rearrangement on BCP. Water ingress leads to urea dimerization.

[Click to download full resolution via product page](#)

Troubleshooting Guide: Curtius Rearrangement

Q3: I isolated a highly insoluble white solid instead of my Boc-protected BCP amine.

- Diagnosis: Symmetrical Urea Formation. The isocyanate intermediate is highly electrophilic. If water is present, it hydrolyzes a portion of the isocyanate to the free amine ().^[2] This free amine is a potent nucleophile and immediately attacks the remaining isocyanate to form the symmetrical urea ().
- The Fix:
 - Use Anhydrous t-BuOH: Ensure the solvent is rigorously dried.

- One-Pot Protocol: Avoid isolating the acyl azide if possible. Use DPPA (Diphenylphosphoryl azide) in refluxing anhydrous t-BuOH. This ensures the isocyanate is trapped immediately by the vast excess of alcohol.

Q4: Can I hydrolyze the BCP-isocyanate with aqueous acid to get the free amine directly?

- Warning: Risk of degradation. While possible, BCP amines can be volatile and difficult to isolate as free bases. Furthermore, acidic hydrolysis of the isocyanate generates CO₂, which can cause foaming.
- Recommendation: Trap with t-BuOH to form the Boc-carbamate first. Purify the Boc-amine (which is stable and lipophilic), then deprotect with HCl/Dioxane to isolate the amine as a stable hydrochloride salt.

Module 3: Comparative Data & Protocols

Methodology Comparison Table

Feature	Turbo-Amide Addition	Radical Amination (Photoredox/Fe)	Curtius Rearrangement
Primary Risk	Moisture sensitivity; Protonation	Oligomerization (Staffanes)	Urea formation; Explosion (Azides)
Key Intermediate	BCP-Magnesium Species	BCP-Radical	BCP-Isocyanate
Typical Yield	60–85%	40–70%	70–90%
Substrate Scope	Good for 2° amines; poor for 1°	Excellent for complex N-heterocycles	Best for simple primary amines
Temperature Limit	< 25 °C (Anion stability)	Room Temp (Photoredox)	Reflux (Rearrangement)

Standardized Protocol: Turbo-Amide Amination

Ref: Adapted from Kanazawa et al. (2019) and commercial technical notes.

- Preparation: Flame-dry a Schlenk flask under Argon.

- Reagent: Add [1.1.1]propellane (0.5 M in Et₂O/THF).
- Activation: Add Turbo-Amide (e.g., TMPMgCl·LiCl, 1.1 equiv) dropwise at 0 °C.
 - Critical Check: Stir for 15 mins. Solution should remain clear/yellow. Turbidity implies moisture.
- Trapping: Add electrophile (e.g., Iodine, CN-source, or H-source) at 0 °C.
- Quench: Warm to RT and quench with NH₄Cl (sat. aq).
- Isolation: Extract with Et₂O. Do not rotovap to dryness if the product is a low-MW free amine (volatility risk). Convert to HCl salt immediately.

References

- Kanazawa, J., et al. "Aminoalkylation of [1.1.1]Propellane Enables Direct Access to High-Value 3-Alkylbicyclo[1.1.1]pentan-1-amines." [3] Organic Letters, 2019.[3]
- Wiberg, K. B., & Walker, F. "[1.1.1]Propellane." Journal of the American Chemical Society, 1982.
- Measom, N. D., et al. "Divergent Strain-Release Amino-Functionalization of [1.1.1]Propellane with Electrophilic Nitrogen-Radicals." Journal of the American Chemical Society, 2020.
- Lopchuk, J. M. "Bicyclo[1.1.1]pentanes: Synthesis and Application in Medicinal Chemistry." Topics in Current Chemistry, 2017.
- Ghosh, A. K., et al. "Curtius Rearrangement: Mechanistic Insight and Recent Applications in Natural Product Syntheses." Molecules, 2023.[4][5][6]

Need Custom Synthesis?

BenchChem offers custom synthesis for rare earth carbides and specific isotopic labeling.

Email: info@benchchem.com or [Request Quote Online](#).

Sources

- [1. Frontiers | The emerging role of radical chemistry in the amination transformation of highly strained \[1.1.1\]propellane: Bicyclo\[1.1.1\]pentylamine as bioisosteres of anilines \[frontiersin.org\]](#)
- [2. masterorganicchemistry.com \[masterorganicchemistry.com\]](#)
- [3. pubs.acs.org \[pubs.acs.org\]](#)
- [4. Iscollege.ac.in \[Iscollege.ac.in\]](#)
- [5. Propellane-free access to bicyclo\[1.1.1\]pentanes - PMC \[pmc.ncbi.nlm.nih.gov\]](#)
- [6. pubs.acs.org \[pubs.acs.org\]](#)
- To cite this document: BenchChem. [Technical Support Center: BCP Amine Synthesis & Optimization]. BenchChem, [2026]. [Online PDF]. Available at: [\[https://www.benchchem.com/product/b3115701/docs#technical-support-center-bcp-amine-synthesis-optimization\]](https://www.benchchem.com/product/b3115701/docs#technical-support-center-bcp-amine-synthesis-optimization)

Disclaimer & Data Validity:

The information provided in this document is for Research Use Only (RUO) and is strictly not intended for diagnostic or therapeutic procedures. While BenchChem strives to provide accurate protocols, we make no warranties, express or implied, regarding the fitness of this product for every specific experimental setup.

Technical Support: The protocols provided are for reference purposes. Unsure if this reagent suits your experiment?

Need Industrial/Bulk Grade? [Request Custom Synthesis Quote](#)

BenchChem

Our mission is to be the trusted global source of essential and advanced chemicals, empowering scientists and researchers to drive progress in science and industry.

Contact

Address: 3281 E Guasti Rd
Ontario, CA 91761, United States
Phone: (601) 213-4426
Email: info@benchchem.com

Contact our Ph.D. Support Team for a compatibility check