

# stability issues of 1-Azaspiro[3.3]heptane hydrochloride in solution

**Author:** BenchChem Technical Support Team. **Date:** April 2026

## Compound of Interest

Compound Name: *1-Azaspiro[3.3]heptane hydrochloride*

CAS No.: *1986337-29-4*

Cat. No.: *B3113873*

[Get Quote](#)

## Technical Support Center: 1-Azaspiro[3.3]heptane Hydrochloride

Welcome to the technical support center for **1-Azaspiro[3.3]heptane hydrochloride**. This guide is designed for researchers, scientists, and drug development professionals to address potential stability issues when working with this compound in solution. As a novel and rigid scaffold, understanding its behavior in various experimental settings is crucial for generating reliable and reproducible data.

### Frequently Asked Questions (FAQs)

This section addresses common questions regarding the stability of **1-Azaspiro[3.3]heptane hydrochloride** in solution.

Q1: What is the general stability of **1-Azaspiro[3.3]heptane hydrochloride** in aqueous solutions?

A1: **1-Azaspiro[3.3]heptane hydrochloride** is anticipated to be relatively stable in aqueous solutions under standard laboratory conditions (room temperature, neutral pH). The spirocyclic nature of the core structure is designed to confer a high degree of metabolic stability, which often translates to good chemical stability.<sup>[1]</sup> However, like all amine-containing compounds, its stability can be influenced by pH, temperature, and the presence of oxidizing agents.

Q2: How does pH affect the stability of **1-Azaspiro[3.3]heptane hydrochloride** solutions?

A2: The stability of **1-Azaspiro[3.3]heptane hydrochloride** is significantly dependent on pH. As the hydrochloride salt, the secondary amine is protonated, which generally protects it from certain degradation pathways. In acidic to neutral solutions, the protonated form will be predominant. In alkaline conditions (pH > pKa, which is expected to be around 10-11 for a secondary amine), the free base is formed. This free base is more nucleophilic and potentially more susceptible to oxidation. Extreme pH conditions (strong acids or bases) coupled with elevated temperatures could promote ring-opening or other degradation reactions.

Q3: Is **1-Azaspiro[3.3]heptane hydrochloride** susceptible to oxidation in solution?

A3: Secondary amines can be susceptible to oxidation, and this is a potential degradation pathway for 1-Azaspiro[3.3]heptane.<sup>[2]</sup> The presence of dissolved oxygen, metal ions (which can act as catalysts), or oxidizing agents (like hydrogen peroxide) can lead to the formation of various oxidation products.<sup>[3]</sup> To minimize oxidative degradation, it is recommended to use degassed solvents and avoid sources of metal contamination.

Q4: What are the recommended storage conditions for solutions of **1-Azaspiro[3.3]heptane hydrochloride**?

A4: For optimal stability, solutions of **1-Azaspiro[3.3]heptane hydrochloride** should be stored at low temperatures (2-8°C or -20°C for long-term storage), protected from light, and in tightly sealed containers to prevent solvent evaporation and exposure to atmospheric oxygen. If possible, preparing fresh solutions for each experiment is the best practice to ensure the integrity of the compound.

Q5: Can I expect any degradation of **1-Azaspiro[3.3]heptane hydrochloride** in common organic solvents?

A5: **1-Azaspiro[3.3]heptane hydrochloride** is expected to be soluble in polar protic solvents like methanol and ethanol, and polar aprotic solvents like DMSO and DMF.<sup>[4]</sup> In general, aprotic solvents are less likely to participate directly in degradation reactions compared to water. However, the stability will still depend on the purity of the solvent (absence of peroxides in ethers, for example) and the storage conditions. It is always advisable to use high-purity, anhydrous solvents when preparing solutions for sensitive applications.

## Troubleshooting Guide

This section provides a structured approach to troubleshoot common stability-related issues you might encounter during your experiments.

Observed Issue	Potential Cause	Recommended Action
Loss of compound potency or concentration over a short period in aqueous solution.	pH-mediated degradation: The pH of your solution may be too high or too low, promoting hydrolysis or other degradation pathways.	- Measure the pH of your solution. - If possible, buffer the solution to a pH range of 4-7. - Prepare fresh solutions before each experiment.
Appearance of unexpected peaks in HPLC or LC-MS analysis.	Oxidative degradation: The compound may be oxidizing due to dissolved oxygen, metal ion contamination, or exposure to oxidizing agents.	- Use degassed solvents for solution preparation. - Consider adding a small amount of an antioxidant (e.g., ascorbic acid), if compatible with your experimental setup. - Ensure all glassware is thoroughly cleaned to remove any metal residues.
Inconsistent results between experimental replicates.	Photodegradation: Exposure to light, especially UV light, can sometimes lead to degradation.	- Protect your solutions from light by using amber vials or covering them with aluminum foil. - Minimize the exposure of your solutions to ambient light during experimental setup.
Significant degradation upon heating.	Thermal instability: The compound may be degrading at elevated temperatures.	- If heating is necessary, perform a time-course experiment at a lower temperature to assess stability. - Consider if a lower temperature or shorter incubation time can be used for your experiment.

## Experimental Protocol: Forced Degradation Study

To systematically evaluate the stability of **1-Azaspiro[3.3]heptane hydrochloride** in your specific experimental conditions, a forced degradation study is recommended. This involves

subjecting the compound to a range of stress conditions to identify potential degradation pathways and products.<sup>[5][6]</sup>

#### 1. Preparation of Stock Solution:

- Prepare a stock solution of **1-Azaspiro[3.3]heptane hydrochloride** at a concentration of 1 mg/mL in a suitable solvent (e.g., water, methanol, or a 50:50 mixture).

#### 2. Stress Conditions:

- **Acid Hydrolysis:** Mix the stock solution with an equal volume of 0.1 M HCl. Incubate at 60°C for 24 hours.
- **Base Hydrolysis:** Mix the stock solution with an equal volume of 0.1 M NaOH. Incubate at 60°C for 24 hours.
- **Oxidation:** Mix the stock solution with an equal volume of 3% hydrogen peroxide. Keep at room temperature for 24 hours.
- **Thermal Degradation:** Incubate the stock solution at 60°C for 24 hours.
- **Photodegradation:** Expose the stock solution in a photostability chamber to UV and visible light as per ICH Q1B guidelines. A control sample should be wrapped in aluminum foil.

#### 3. Sample Analysis:

- At various time points (e.g., 0, 4, 8, 24 hours), withdraw an aliquot of each stressed solution.
- For acid and base hydrolysis samples, neutralize the solution before analysis.
- Analyze all samples by a stability-indicating HPLC method (e.g., reversed-phase with UV detection) or LC-MS to determine the percentage of the parent compound remaining and to detect any degradation products.

#### 4. Data Interpretation:

- Compare the chromatograms of the stressed samples to that of the unstressed control.

- Quantify the degradation of **1-Azaspiro[3.3]heptane hydrochloride** under each condition.
- If significant degradation is observed, further characterization of the degradation products by LC-MS/MS or NMR may be necessary.

## Visualizing Experimental Workflows and Potential Degradation

### Experimental Workflow for Forced Degradation Study

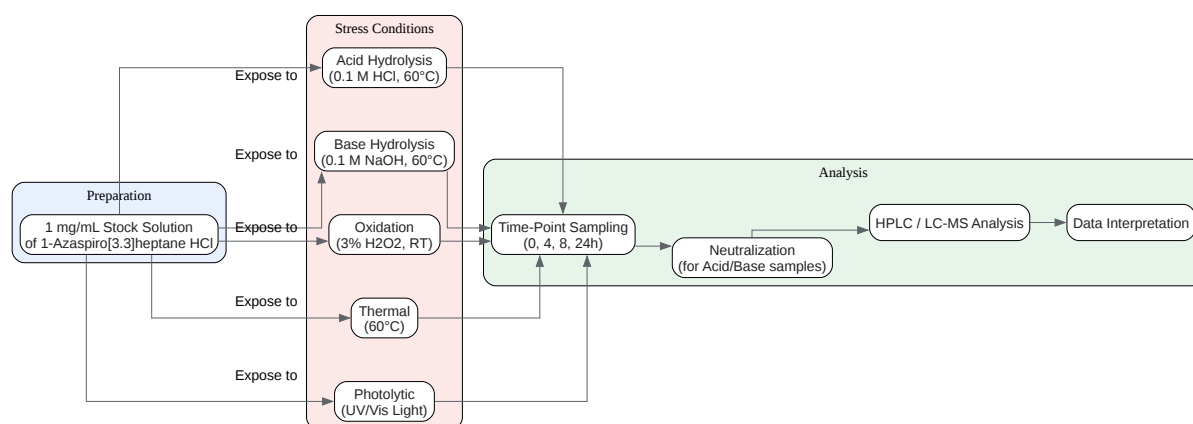

[Click to download full resolution via product page](#)

Caption: Workflow for the forced degradation study of **1-Azaspiro[3.3]heptane hydrochloride**.

## Plausible Degradation Pathway Under Harsh Conditions

While 1-Azaspiro[3.3]heptane is generally stable, under forcing conditions such as strong acid or base with heat, ring-opening of the strained azetidine ring is a plausible, albeit likely minor, degradation pathway.

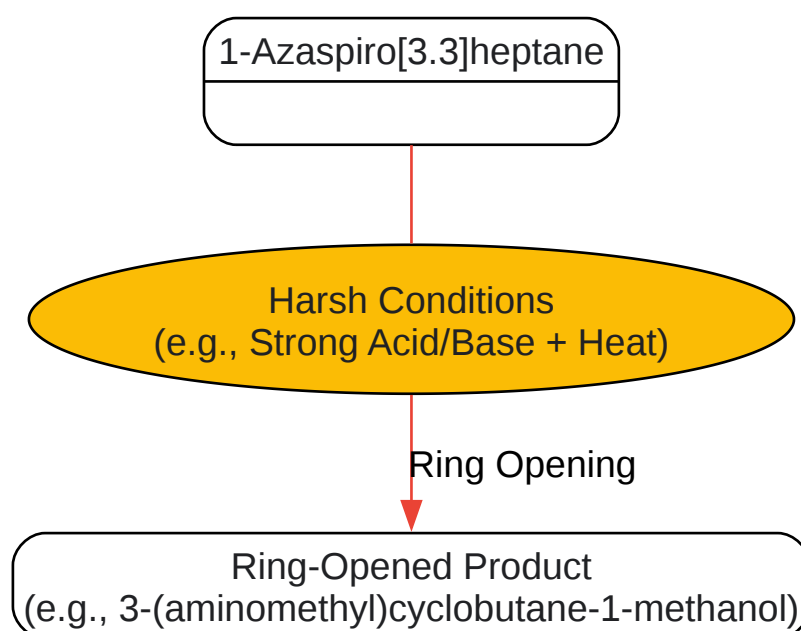

[Click to download full resolution via product page](#)

Caption: Hypothetical degradation pathway via ring-opening under harsh conditions.

## References

- Mykhailiuk, P. K., et al. (2023). 1-Azaspiro[3.3]heptane as a Bioisostere of Piperidine. *Angewandte Chemie International Edition*, 62(51), e202311583. Available from: [\[Link\]](#)
- International Council for Harmonisation. (2003). ICH Q1A(R2): Stability Testing of New Drug Substances and Products. Available from: [\[Link\]](#)
- International Council for Harmonisation. (1996). ICH Q1B: Photostability Testing of New Drug Substances and Products. Available from: [\[Link\]](#)

- Sharma, M. K., & Murugesan, M. (n.d.). Forced Degradation Study an Essential Approach to Develop Stability Indicating Method. *Journal of Pharmaceutical and Biomedical Analysis*.
- Pharmaguideline. (n.d.). Forced Degradation Study in Pharmaceutical Stability. Available from: [\[Link\]](#)
- SGS. (2011). How to Approach a Forced Degradation Study. Available from: [\[Link\]](#)
- Brümmer, H. (2011).
- Alsante, K. M., et al. (2007). Forced degradation: what is the value?. *Pharmaceutical Technology*, 31(4), 56-68.
- Baertschi, S. W., Alsante, K. M., & Reed, R. A. (Eds.). (2011).
- Reynolds, D. W., et al. (2002). Available guidance and best practices for conducting forced degradation studies. *Pharmaceutical Technology*, 26(2), 48-56.
- Singh, S., & Bakshi, M. (2000). Guidance on conduct of stress tests to determine inherent stability of drugs. *Pharmaceutical technology*, 24(1), 1-14.
- Klick, S., et al. (2005). Toward a general strategy for degradation pathway elucidation of drug molecules. *Journal of Pharmaceutical and Biomedical Analysis*, 37(3), 439-445.
- Szostak, R. (2017). Forced degradation of pharmaceuticals. Royal Society of Chemistry.
- Waterman, K. C., & Adami, R. C. (2005). Accelerated aging: Prediction of chemical stability of pharmaceuticals. *International journal of pharmaceutics*, 293(1-2), 101-125.
- Caron, E., et al. (2019). Spiro[3.3]heptane as a non-collinear benzene bioisostere. ChemRxiv.
- Mykhailiuk, P. K. (2017). 1-Substituted 2-Azaspiro [3.3] heptanes: Overlooked Motifs for Drug Discovery.
- Stepanov, A. A., et al. (2024). 1-Oxa-2, 6-diazaspiro [3.3] heptane as a New Potential Piperazine Bioisostere.
- BenchChem. (n.d.). Solubility Profile of 1-Azaspiro[3.6]decane in Common Organic Solvents: A Technical Guide.
- Voice, A. M. (2021).
- Sayre, C. M., & Nielsen, S. O. (2011). Oxidative degradation of aminosilica adsorbents relevant to postcombustion CO<sub>2</sub> capture. *Energy & Fuels*, 25(5), 2416-2425.
- Smirnova, O. V., et al. (2021). Spirocyclic nitroxides as versatile tools in modern natural sciences: from synthesis to applications. Part I. Old and new synthetic approaches to spirocyclic nitroxyl radicals. *Molecules*, 26(11), 3372.
- Gembus, V., et al. (2022). Influence of the Photodegradation of Azathioprine on DNA and Cells. *International Journal of Molecular Sciences*, 23(22), 14389.

- Skibiński, R., & Komsta, Ł. (2012). The stability and degradation kinetics of acetylsalicylic acid in different organic solutions revisited—an UHPLC–ESI-QTOF spectrometry study.
- Li, M., et al. (2015). Degradation kinetics of pirenzepine hydrochloride in aqueous solution. *Journal of pharmaceutical and biomedical analysis*, 107, 219-225.

### Need Custom Synthesis?

BenchChem offers custom synthesis for rare earth carbides and specific isotopic labeling.

Email: [info@benchchem.com](mailto:info@benchchem.com) or [Request Quote Online](#).

## Sources

- [1. mdpi.com \[mdpi.com\]](https://www.mdpi.com)
- [2. experts.umn.edu \[experts.umn.edu\]](https://www.experts.umn.edu)
- [3. researchgate.net \[researchgate.net\]](https://www.researchgate.net)
- [4. pdf.benchchem.com \[pdf.benchchem.com\]](https://pdf.benchchem.com)
- [5. ajpsonline.com \[ajpsonline.com\]](https://www.ajpsonline.com)
- [6. Forced Degradation Study in Pharmaceutical Stability | Pharmaguideline \[pharmaguideline.com\]](https://www.pharmaguideline.com)
- To cite this document: BenchChem. [stability issues of 1-Azaspiro[3.3]heptane hydrochloride in solution]. BenchChem, [2026]. [Online PDF]. Available at: [\[https://www.benchchem.com/product/b3113873/docs#stability-issues-of-1-azaspiro-3-3-heptane-hydrochloride-in-solution\]](https://www.benchchem.com/product/b3113873/docs#stability-issues-of-1-azaspiro-3-3-heptane-hydrochloride-in-solution)

---

### Disclaimer & Data Validity:

The information provided in this document is for Research Use Only (RUO) and is strictly not intended for diagnostic or therapeutic procedures. While BenchChem strives to provide accurate protocols, we make no warranties, express or implied, regarding the fitness of this product for every specific experimental setup.

**Technical Support:** The protocols provided are for reference purposes. Unsure if this reagent suits your experiment?

**Need Industrial/Bulk Grade?** [Request Custom Synthesis Quote](#)

## BenchChem

Our mission is to be the trusted global source of essential and advanced chemicals, empowering scientists and researchers to drive progress in science and industry.

### Contact

Address: 3281 E Guasti Rd  
Ontario, CA 91761, United States  
Phone: (601) 213-4426  
Email: [info@benchchem.com](mailto:info@benchchem.com)

[Contact our Ph.D. Support Team for a compatibility check](#)