

Synthesis of Bicyclic Azamines from Piperidine Derivatives: An Application Note and Protocol Guide

Author: BenchChem Technical Support Team. **Date:** April 2026

Compound of Interest

Compound Name:	2-(2-Bromoethyl)piperidine hydrobromide
CAS No.:	1564-77-8
Cat. No.:	B3106047

[Get Quote](#)

For Researchers, Scientists, and Drug Development Professionals

Abstract

Bicyclic azamines, nitrogen-containing fused ring systems, are privileged scaffolds in medicinal chemistry, appearing in numerous pharmaceuticals and natural products.[1][2] Their rigidified conformations allow for precise presentation of pharmacophoric elements, leading to enhanced potency and selectivity for biological targets. This guide provides a detailed overview of synthetic strategies for constructing bicyclic azamines, with a particular focus on methods commencing from readily available piperidine derivatives. We will delve into the mechanistic underpinnings of key cyclization reactions, offer detailed, step-by-step protocols for their execution, and discuss common challenges and optimization strategies.

Introduction: The Significance of Bicyclic Azamines

The piperidine ring is a cornerstone in drug design, present in a vast array of approved therapeutic agents.[1][3] By incorporating the piperidine moiety into a bicyclic framework, such as indolizidines, quinolizidines, and other fused systems, medicinal chemists can access novel chemical space with distinct three-dimensional geometries.[4][5] These rigid structures often lead to improved binding affinity and metabolic stability compared to their monocyclic counterparts. The development of efficient and stereoselective methods for the synthesis of these bicyclic azamines is therefore a critical endeavor in modern drug discovery.[2][6]

This application note will explore several powerful intramolecular cyclization strategies that utilize functionalized piperidines as key building blocks. These methods provide a versatile toolkit for accessing a diverse range of bicyclic azamine cores.

Key Synthetic Strategies for Bicyclic Azamine Formation

The construction of a second ring onto a pre-existing piperidine core is typically achieved through intramolecular cyclization reactions. The choice of strategy depends on the desired ring system, available starting materials, and required stereochemical control.

Intramolecular Cyclization of Piperidine Derivatives

The direct formation of a new C-N or C-C bond originating from the piperidine ring is a fundamental approach to bicyclic azamine synthesis.[1] This can be achieved through various methods, including:

- **Aza-Prins Cyclization:** This powerful reaction involves the acid-promoted cyclization of a homoallylic amine onto an aldehyde or ketone.[7][8] When the homoallylic amine is part of a piperidine ring, this leads to the formation of indolizidine or quinolizidine skeletons.[9] The reaction proceeds through an N-acyliminium ion intermediate, which is then attacked by the tethered alkene.[7] The choice of Lewis or Brønsted acid is crucial for controlling the reaction pathway and stereoselectivity.[8]
- **Pictet-Spengler Reaction:** A classic and highly effective method for constructing tetrahydro- β -carboline and tetrahydroisoquinoline ring systems, the Pictet-Spengler reaction can be adapted for the synthesis of more complex bicyclic azamines.[10][11] This reaction involves the condensation of a β -arylethylamine with an aldehyde or ketone, followed by an acid-

catalyzed intramolecular electrophilic aromatic substitution.[11][12] By using a piperidine derivative bearing a tethered aromatic group, this strategy can be employed to generate fused bicyclic systems.

- **Reductive Amination:** Intramolecular reductive amination is a robust method for forming nitrogen-containing rings.[13][14] This two-step, one-pot process involves the formation of an imine or enamine from a precursor containing both an amine and a carbonyl group (or a masked carbonyl), followed by in-situ reduction.[13] For the synthesis of bicyclic azamines, a piperidine derivative containing a tethered aldehyde, ketone, or a group that can be converted to a carbonyl is required.[15]
- **Radical-Mediated Cyclization:** Intramolecular radical cyclizations offer a complementary approach, particularly for the formation of five- and six-membered rings.[1] These reactions typically involve the generation of a radical on a side chain attached to the piperidine nitrogen or carbon framework, which then attacks a tethered unsaturated system (e.g., an alkene or alkyne).[16]
- **Transition Metal-Catalyzed Cyclizations:** Modern organic synthesis offers a plethora of transition metal-catalyzed reactions that can be applied to the synthesis of bicyclic azamines.[1] For instance, palladium-catalyzed intramolecular aza-Heck reactions can be used to form C-C bonds, leading to fused piperidine systems.[1]

Tandem and Cascade Reactions

More sophisticated approaches involve tandem or cascade reactions where multiple bond-forming events occur in a single operation. These strategies are highly efficient and can rapidly build molecular complexity.[10][17] An example is a tandem aza-Prins/Ritter reaction, where the initial cyclization is followed by trapping of the resulting carbocation with a nitrile.[18]

Experimental Protocols

Here, we provide detailed protocols for two common and versatile methods for synthesizing bicyclic azamines from piperidine derivatives.

Protocol 1: Aza-Prins Cyclization for Indolizidine Synthesis

This protocol describes the synthesis of a substituted indolizidine core via an intramolecular aza-Prins cyclization of an N-homoallylic piperidine derivative.

Reaction Scheme:

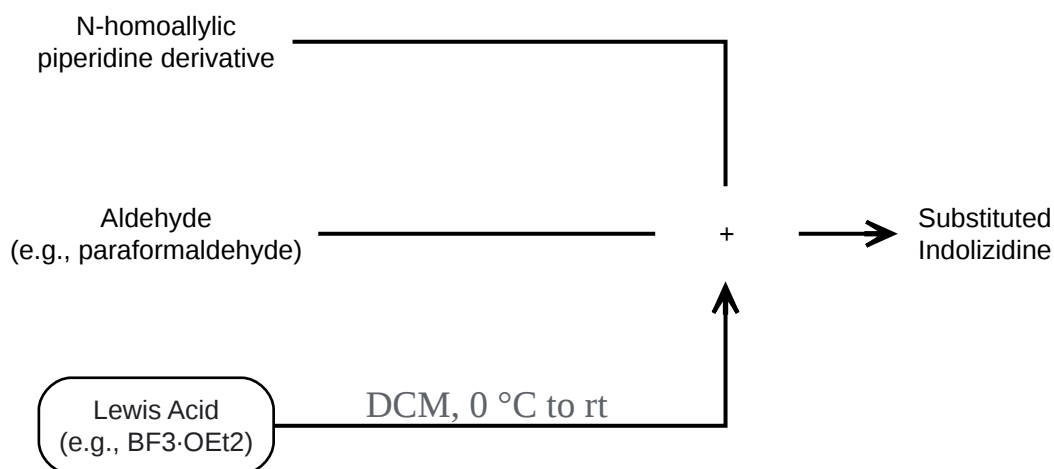

[Click to download full resolution via product page](#)

Aza-Prins cyclization for indolizidine synthesis.

Materials:

- N-homoallylic piperidine derivative (1.0 equiv)
- Paraformaldehyde (1.5 equiv)
- Boron trifluoride diethyl etherate (BF₃·OEt₂) (1.2 equiv)
- Dichloromethane (DCM), anhydrous
- Saturated aqueous sodium bicarbonate (NaHCO₃) solution
- Brine
- Anhydrous magnesium sulfate (MgSO₄)
- Silica gel for column chromatography

Procedure:

- To a solution of the N-homoallylic piperidine derivative (1.0 equiv) and paraformaldehyde (1.5 equiv) in anhydrous DCM at 0 °C under an inert atmosphere (e.g., nitrogen or argon), add $\text{BF}_3 \cdot \text{OEt}_2$ (1.2 equiv) dropwise.
- Allow the reaction mixture to warm to room temperature and stir for 2-4 hours, or until TLC analysis indicates complete consumption of the starting material.
- Quench the reaction by the slow addition of saturated aqueous NaHCO_3 solution.
- Separate the organic layer and extract the aqueous layer with DCM (3 x 20 mL).
- Combine the organic layers, wash with brine, dry over anhydrous MgSO_4 , and filter.
- Concentrate the filtrate under reduced pressure to obtain the crude product.
- Purify the crude product by flash column chromatography on silica gel using an appropriate eluent system (e.g., a gradient of ethyl acetate in hexanes) to afford the desired indolizidine product.

Causality and Experimental Choices:

- Lewis Acid: $\text{BF}_3 \cdot \text{OEt}_2$ is a common Lewis acid used to promote the formation of the reactive N-acyliminium ion intermediate. Other Lewis acids such as TiCl_4 or Brønsted acids like p-toluenesulfonic acid can also be employed, and the choice may influence the stereochemical outcome.^[8]
- Aldehyde Source: Paraformaldehyde is a convenient source of formaldehyde. Other aldehydes or ketones can be used to introduce different substituents on the newly formed ring.
- Anhydrous Conditions: The reaction is sensitive to water, which can hydrolyze the Lewis acid and the N-acyliminium ion intermediate. Therefore, the use of anhydrous solvents and an inert atmosphere is crucial for optimal results.

Protocol 2: Intramolecular Reductive Amination for Quinolizidine Synthesis

This protocol outlines the synthesis of a quinolizidine scaffold via a one-pot intramolecular reductive amination of a piperidine derivative bearing a keto-aldehyde side chain.

Reaction Scheme:

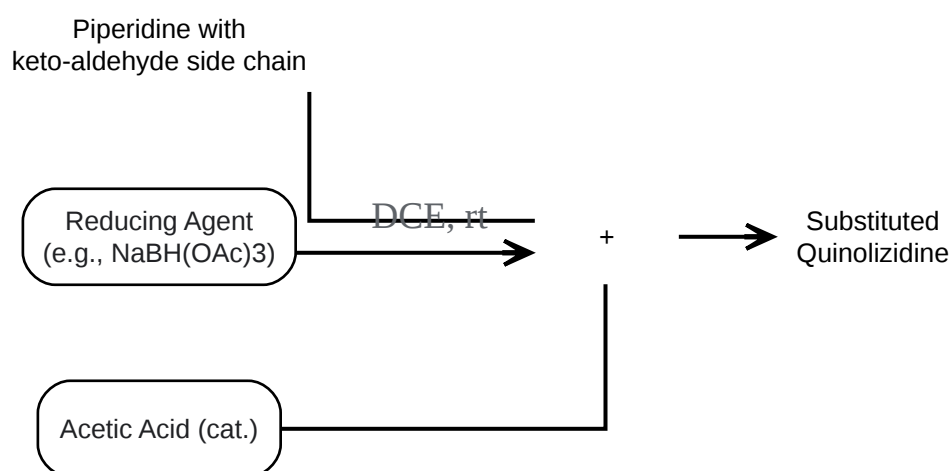

[Click to download full resolution via product page](#)

Intramolecular reductive amination for quinolizidine synthesis.

Materials:

- Piperidine derivative with a keto-aldehyde side chain (1.0 equiv)
- Sodium triacetoxyborohydride (NaBH(OAc)₃) (1.5 equiv)
- Acetic acid (catalytic amount)
- 1,2-Dichloroethane (DCE), anhydrous
- Saturated aqueous sodium bicarbonate (NaHCO₃) solution
- Brine
- Anhydrous sodium sulfate (Na₂SO₄)

- Silica gel for column chromatography

Procedure:

- To a solution of the piperidine derivative (1.0 equiv) in anhydrous DCE, add a catalytic amount of acetic acid.
- Add sodium triacetoxyborohydride (1.5 equiv) portion-wise at room temperature.
- Stir the reaction mixture at room temperature for 12-24 hours, monitoring the progress by TLC.
- Upon completion, carefully quench the reaction with saturated aqueous NaHCO₃ solution.
- Extract the mixture with DCM (3 x 20 mL).
- Combine the organic layers, wash with brine, dry over anhydrous Na₂SO₄, and filter.
- Concentrate the filtrate under reduced pressure.
- Purify the crude product by flash column chromatography on silica gel to yield the quinolizidine product.

Causality and Experimental Choices:

- Reducing Agent: Sodium triacetoxyborohydride is a mild and selective reducing agent that is particularly effective for reductive aminations.^[19] It is less basic than other common reducing agents like sodium borohydride, which helps to minimize side reactions.
- Acid Catalyst: Acetic acid catalyzes the formation of the iminium ion intermediate, which is then reduced.^[19]
- Solvent: DCE is a common solvent for reductive amination reactions as it is relatively non-polar and aprotic.

Data Presentation

The choice of synthetic method can significantly impact the yield and stereoselectivity of the bicyclic azamine product. The following table summarizes typical outcomes for the synthesis of indolizidine and quinolizidine cores using the described methods.

Synthetic Method	Bicyclic Core	Typical Yield (%)	Diastereoselectivity (d.r.)	Key Considerations
Aza-Prins Cyclization	Indolizidine	60-85	5:1 to >20:1	Lewis acid choice, substrate stereochemistry. [9]
Intramolecular Reductive Amination	Quinolizidine	70-90	Varies	Nature of the reducing agent, pH control. [13]
Pictet-Spengler Reaction	Tetrahydro- β -carboline fused piperidine	50-80	Generally good	Electron-donating groups on the aromatic ring facilitate the reaction. [10]

Troubleshooting and Optimization

Common Issues & Solutions

Issue	Potential Cause	Suggested Solution
Low Yield	Incomplete reaction; decomposition of starting material or product.	Optimize reaction time and temperature. Use a milder Lewis acid or reducing agent. Ensure anhydrous conditions. [20]
Poor Stereoselectivity	Non-optimal catalyst or reaction conditions.	Screen different Lewis or Brønsted acids. Vary the reaction temperature. Consider using a chiral catalyst for asymmetric synthesis. [20]
Formation of Side Products	Polymerization, over-reduction, or alternative cyclization pathways.	Lower the reaction temperature. Use a more selective reducing agent. Adjust the stoichiometry of reagents. [20]

Conclusion

The synthesis of bicyclic azamines from piperidine derivatives is a rich and diverse field, offering numerous strategies for the construction of these medicinally important scaffolds. Intramolecular cyclization reactions, such as the aza-Prins, Pictet-Spengler, and reductive amination, provide reliable and versatile methods for accessing a wide range of fused heterocyclic systems. By understanding the underlying mechanisms and carefully selecting reaction conditions, researchers can efficiently synthesize complex bicyclic azamines for applications in drug discovery and natural product synthesis.

References

- Frolov, N., & Vereshchagin, A. (2023). Piperidine Derivatives: Recent Advances in Synthesis and Pharmacological Applications. *International Journal of Molecular Sciences*, 24(3), 2937. [\[Link\]](#)
- Scarpino, A., et al. (2016). The Pictet-Spengler Reaction Updates Its Habits. *Molecules*, 21(7), 883. [\[Link\]](#)

- Li, J., et al. (2017). The aza-Prins cyclization reaction catalyzed by ZrCl₄ and NHC (N-heterocyclic carbene) metal complexes. ResearchGate. [\[Link\]](#)
- Larsen, C. H., & Grotjahn, D. B. (2012). The Pictet-Spengler Reaction. Comprehensive Organic Name Reactions and Reagents, 1-25. [\[Link\]](#)
- D'Adamio, G., et al. (2021). Reductive Amination Routes in the Synthesis of Piperidine IminoSugars. *Molecules*, 26(11), 3379. [\[Link\]](#)
- Back, T. G., & Nakajima, K. (2000). A convenient new route to piperidines, pyrrolizidines, indolizidines, and quinolizidines by cyclization of acetylenic sulfones with beta and gamma-chloroamines. Enantioselective total synthesis of indolizidines (-)-167B, (-)-209D, (-)-209B, and (-)-207A. *The Journal of Organic Chemistry*, 65(15), 4543–4552. [\[Link\]](#)
- Comins, D. L., & Dehghani, A. (1992). Enantioselective Synthesis of Piperidine, Indolizidine, and Quinolizidine Alkaloids from a Phenylglycinol-Derived δ -Lactam. *The Journal of Organic Chemistry*, 57(21), 5633-5635. [\[Link\]](#)
- Shcherbakova, V., et al. (2021). Bicyclic Piperidines via [2 + 2] Photocycloaddition. *The Journal of Organic Chemistry*, 86(3), 2200–2209. [\[Link\]](#)
- Buffat, M. G. (2004). Recent advances in the synthesis of piperidones and piperidines. *Tetrahedron*, 60(8), 1701-1729. [\[Link\]](#)
- Ferreira, F., et al. (2023). C–H Annulation in Azines to Obtain 6,5-Fused-Bicyclic Heteroaromatic Cores for Drug Discovery. *Molecules*, 28(24), 8031. [\[Link\]](#)
- Smith, A. M., et al. (2019). A stereoselective aza-Prins reaction: rapid access to enantiopure piperidines and pipercolic acids. *Chemical Science*, 10(12), 3597–3602. [\[Link\]](#)
- Aslam, N. F. B. M. (2017). Synthesis of piperidine and quinolizidine alkaloids. Nanyang Technological University. [\[Link\]](#)
- Reddy, T. R., & Ghorai, M. K. (2011). A facile aminocyclization for the synthesis of pyrrolidine and piperidine derivatives. *Organic & Biomolecular Chemistry*, 9(11), 4072-4075. [\[Link\]](#)

- Forró, E., & Fülöp, F. (2019). Studies on the Synthesis of Some Functionalized Azaheterocycles through Oxidative Ring Opening/Ring Closing by Reductive Amination. *ChemistrySelect*, 4(12), 3465-3469. [[Link](#)]
- Chio, F. I. C., et al. (2015). Synthesis of Azabicycles via Cascade Aza-Prins Reactions: Accessing the Indolizidine and Quinolizidine Cores. *The Journal of Organic Chemistry*, 80(20), 10074–10084. [[Link](#)]
- Mohamed Aslam, N. F. (2017). Synthesis of piperidine and quinolizidine alkaloids. Nanyang Technological University. [[Link](#)]
- Frolov, N., & Vereshchagin, A. (2023). Piperidine Derivatives: Recent Advances in Synthesis and Pharmacological Applications. *Semantic Scholar*. [[Link](#)]
- Baig, G. U. (1986). The Medicinal Chemistry of Bicyclic Systems Containing a NNN Bond. Aston University. [[Link](#)]
- Reddy, B. V. S., et al. (2017). The Aza-Prins Reaction in the Synthesis of Natural Products and Analogues. *European Journal of Organic Chemistry*, 2017(20), 2849-2865. [[Link](#)]
- Frolov, N. A., & Vereshchagin, A. N. (2023). Main routes to the piperidine cycle synthesis. *ResearchGate*. [[Link](#)]
- Savych, V., et al. (2022). Bicyclic Pyrrolidines for Medicinal Chemistry via [3 + 2]-Cycloaddition. *The Journal of Organic Chemistry*, 87(15), 9899–9911. [[Link](#)]
- Frontier, A. (2015). New cyclization strategies enabled by the alkynyl Prins reaction. *American Chemical Society*. [[Link](#)]
- Grygorenko, O. O., et al. (2021). Bicyclic Isosteres of Pyridine/Piperidine: From Synthesis to Applications. *Chemical Reviews*, 121(21), 13245–13303. [[Link](#)]
- Hlushkov, D. S., et al. (2023). BICYCLIC METHYLENE AZIRIDINE IN REACTIONS WITH C- AND N-NUCLEOPHILES. *Journal of Chemistry and Technologies*, 31(4), 519-528. [[Link](#)]
- Frolov, N. A., & Vereshchagin, A. N. (2023). Piperidine Derivatives: Recent Advances in Synthesis and Pharmacological Applications. *International Journal of Molecular Sciences*,

24(3), 2937. [\[Link\]](#)

- Gati, W., et al. (2021). Leveraging the 1,3-azadiene-anhydride reaction for the synthesis of functionalized piperidines bearing up to five contiguous stereocenters. *Organic & Biomolecular Chemistry*, 19(48), 10565-10570. [\[Link\]](#)
- Reddy, G. S., et al. (2014). Nitrile stabilized synthesis of pyrrolidine and piperidine derivatives via tandem alkynyl aza-Prins–Ritter reactions. *Organic & Biomolecular Chemistry*, 12(4), 609-613. [\[Link\]](#)
- Alec, C. (2024). Strategies for Selective Reductive Amination in Organic Synthesis and Catalysis. *Journal of Organic and Inorganic Chemistry*, 7(1), 1-3. [\[Link\]](#)
- Frolov, N., & Vereshchagin, A. (2023). Piperidine Derivatives: Recent Advances in Synthesis and Pharmacological Applications. *International Journal of Molecular Sciences*, 24(3), 2937. [\[Link\]](#)
- Grygorenko, O. O., et al. (2021). Bicyclic Isosteres of Pyridine/Piperidine: From Synthesis to Applications. *ResearchGate*. [\[Link\]](#)
- Check, C. T., & Thomson, R. J. (2020). Synthesis of aza-quaternary centers via Pictet–Spengler reactions of ketonitrone. *Organic & Biomolecular Chemistry*, 18(37), 7271-7275. [\[Link\]](#)
- Chamberlin, A. R., & Chung, J. Y. L. (1991). The Synthesis of Bicyclic Piperazinone and Related Derivatives. *Methods in Molecular Biology*, 6, 283-298. [\[Link\]](#)
- Reddy, C. R., et al. (2012). Tandem Synthesis of Pyrrolidine and Piperidine Derivatives from Propargylic Alcohols Under Multimetallic Catalysis. *Chemistry – An Asian Journal*, 7(8), 1821-1825. [\[Link\]](#)
- Pearson. (n.d.). Show how to synthesize the following amines from the indicated st... | Study Prep. Pearson+. [\[Link\]](#)
- Al-Hiari, Y. M. (2018). Application of the Asymmetric Pictet–Spengler Reaction in the Total Synthesis of Natural Products and Relevant Biologically Active Compounds. *Molecules*, 23(4), 943. [\[Link\]](#)

- Kumar, V., et al. (2016). Reductive amination and amide synthesis. Reagents and conditions. ResearchGate. [\[Link\]](#)
- Grygorenko, O. O., et al. (2021). Synthesis of aza-bicyclic building blocks for medicinal chemistry. ResearchGate. [\[Link\]](#)
- Utkina, E. N., et al. (2018). Synthesis of tetrahydrofuro[3,2-c]pyridines via Pictet–Spengler reaction. Beilstein Journal of Organic Chemistry, 14, 141-147. [\[Link\]](#)
- Elderfield, R. C. (1983). Piperidine Synthesis. Defense Technical Information Center. [\[Link\]](#)
- University of Leeds. (n.d.). SYNTHESIS OF PIPERIDINES USING ORGANOMETALLIC CHEMISTRY. White Rose eTheses Online. [\[Link\]](#)
- Grygorenko, O. O., et al. (2021). Bicyclic Isosteres of Pyridine/Piperidine: From Synthesis to Applications. PubMed. [\[Link\]](#)

Need Custom Synthesis?

BenchChem offers custom synthesis for rare earth carbides and specific isotopic labeling.

Email: info@benchchem.com or [Request Quote Online](#).

Sources

- [1. Piperidine Derivatives: Recent Advances in Synthesis and Pharmacological Applications - PMC \[pmc.ncbi.nlm.nih.gov\]](#)
- [2. C–H Annulation in Azines to Obtain 6,5-Fused-Bicyclic Heteroaromatic Cores for Drug Discovery \[mdpi.com\]](#)
- [3. semanticscholar.org \[semanticscholar.org\]](#)
- [4. enamine.net \[enamine.net\]](#)
- [5. mykhailiukchem.org \[mykhailiukchem.org\]](#)
- [6. researchgate.net \[researchgate.net\]](#)
- [7. researchgate.net \[researchgate.net\]](#)
- [8. gala.gre.ac.uk \[gala.gre.ac.uk\]](#)

- [9. Synthesis of Azabicycles via Cascade Aza-Prins Reactions: Accessing the Indolizidine and Quinolizidine Cores - PubMed \[pubmed.ncbi.nlm.nih.gov\]](#)
- [10. The Pictet-Spengler Reaction Updates Its Habits - PMC \[pmc.ncbi.nlm.nih.gov\]](#)
- [11. The Pictet-Spengler Reaction \[ebrary.net\]](#)
- [12. Application of the Asymmetric Pictet–Spengler Reaction in the Total Synthesis of Natural Products and Relevant Biologically Active Compounds \[mdpi.com\]](#)
- [13. researchgate.net \[researchgate.net\]](#)
- [14. jocpr.com \[jocpr.com\]](#)
- [15. real.mtak.hu \[real.mtak.hu\]](#)
- [16. Piperidine Derivatives: Recent Advances in Synthesis and Pharmacological Applications \[mdpi.com\]](#)
- [17. researchgate.net \[researchgate.net\]](#)
- [18. Nitrile stabilized synthesis of pyrrolidine and piperidine derivatives via tandem alkynyl aza-Prins–Ritter reactions - Organic & Biomolecular Chemistry \(RSC Publishing\) \[pubs.rsc.org\]](#)
- [19. researchgate.net \[researchgate.net\]](#)
- [20. pdf.benchchem.com \[pdf.benchchem.com\]](#)
- To cite this document: BenchChem. [Synthesis of Bicyclic Azamines from Piperidine Derivatives: An Application Note and Protocol Guide]. BenchChem, [2026]. [Online PDF]. Available at: [<https://www.benchchem.com/product/b3106047/docs#synthesis-of-bicyclic-azamines-from-piperidine-derivatives-an-application-note-and-protocol-guide>]

Disclaimer & Data Validity:

The information provided in this document is for Research Use Only (RUO) and is strictly not intended for diagnostic or therapeutic procedures. While BenchChem strives to provide accurate protocols, we make no warranties, express or implied, regarding the fitness of this product for every specific experimental setup.

Technical Support: The protocols provided are for reference purposes. Unsure if this reagent suits your experiment?

Need Industrial/Bulk Grade? [Request Custom Synthesis Quote](#)

BenchChem

Our mission is to be the trusted global source of essential and advanced chemicals, empowering scientists and researchers to drive progress in science and industry.

Contact

Address: 3281 E Guasti Rd

Ontario, CA 91761, United States

Phone: (601) 213-4426

Email: info@benchchem.com

[Contact our Ph.D. Support Team for a compatibility check](#)