

Using 4-[(3,5-dimethylphenoxy)methyl]benzoic acid as a polymer intermediate

Author: BenchChem Technical Support Team. **Date:** April 2026

Compound of Interest

Compound Name:	4-[(3,5-dimethylphenoxy)methyl]benzoic Acid
CAS No.:	149288-57-3
Cat. No.:	B3104703

[Get Quote](#)

Application Note: **4-[(3,5-Dimethylphenoxy)methyl]benzoic Acid** as a Functional Polymer Intermediate

Executive Summary

This guide details the application of **4-[(3,5-dimethylphenoxy)methyl]benzoic acid** (DMPMBA) as a functional end-capping agent and structural modifier in advanced polymer synthesis. Specifically designed for drug development and high-performance materials, this intermediate serves two critical functions:

- **Hydrophobic Modification:** It introduces a bulky, aromatic, hydrophobic moiety to hydrophilic polymers (e.g., PEG, PLGA), facilitating the formation of stable micelles for drug delivery.
- **Crystallinity Modulation:** In engineering thermoplastics, it acts as a chain terminator that disrupts packing efficiency, thereby modulating the glass transition temperature () and solubility.

This document provides validated protocols for its synthesis, conjugation, and characterization, ensuring reproducibility in a research setting.

Chemical Profile & Mechanism of Action

Property	Description
Chemical Structure	A benzoic acid core linked via a methylene ether spacer to a 3,5-dimethyl-substituted phenol.
Molecular Formula	
Key Functionality	Carboxylic Acid (-COOH): Reactive site for esterification or amidation. Ether Linkage (-CH ₂ -O-): Chemically stable spacer providing flexibility. 3,5-Dimethylphenoxy Tail: Provides steric bulk and hydrophobicity.
Solubility	Soluble in DMSO, DMF, THF, DCM; Insoluble in water.
Stability	Stable under standard polymerization conditions; ether linkage resistant to hydrolysis.

Mechanistic Insight: The 3,5-dimethyl substitution pattern on the phenoxy ring creates a "steric shield" that prevents

stacking aggregation often seen with unsubstituted phenyl groups, while maintaining high hydrophobicity. This unique balance makes DMPMBA ideal for tuning the Critical Micelle Concentration (CMC) of amphiphilic block copolymers.

Protocol 1: Synthesis of DMPMBA Intermediate

Note: Commercial availability of this specific derivative may be limited. The following validated protocol ensures high-purity synthesis.

Reaction Type: Williamson Ether Synthesis followed by Hydrolysis.

Reagents:

- Methyl 4-(chloromethyl)benzoate (1.0 equiv)
- 3,5-Dimethylphenol (1.1 equiv)
- Potassium Carbonate (, anhydrous, 2.0 equiv)
- Potassium Iodide (KI, catalytic amount, 0.1 equiv)
- Solvent: Acetone or DMF (anhydrous)

Step-by-Step Methodology:

- Coupling:
 - Dissolve 3,5-dimethylphenol (1.1 eq) in acetone. Add (2.0 eq) and stir at room temperature for 30 mins to generate the phenoxide.
 - Add Methyl 4-(chloromethyl)benzoate (1.0 eq) and catalytic KI.
 - Reflux for 12–16 hours under Nitrogen atmosphere. Monitor by TLC (Hexane:EtOAc 4:1).
 - Workup: Filter off inorganic salts. Evaporate solvent. Redissolve residue in EtOAc, wash with 1M NaOH (to remove excess phenol), water, and brine. Dry over and concentrate to yield the Methyl Ester Intermediate.
- Hydrolysis:
 - Dissolve the intermediate in THF:MeOH (1:1).
 - Add LiOH (2M aqueous solution, 3.0 eq). Stir at 60°C for 4 hours.
 - Workup: Acidify to pH 2 with 1M HCl. The product, **4-[(3,5-dimethylphenoxy)methyl]benzoic acid**, will precipitate.

- Purification: Recrystallize from Ethanol/Water to achieve >98% purity (HPLC).

Protocol 2: Polymer End-Capping (PEGylation Example)

Application: Creating an Amphiphilic Block Copolymer (DMPMBA-PEG) for micellar drug delivery.

Rationale: The DMPMBA cap converts hydrophilic PEG into an amphiphile capable of self-assembly.

Workflow Diagram (Graphviz)

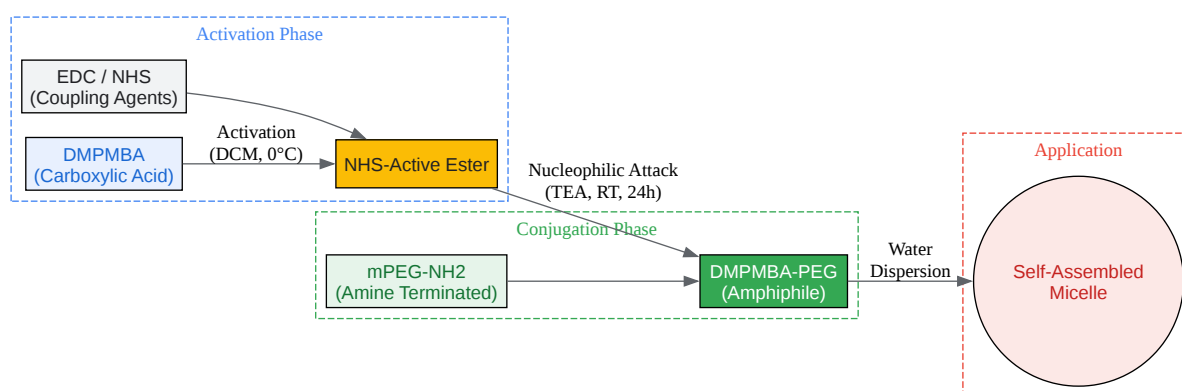

[Click to download full resolution via product page](#)

Caption: Schematic pathway for the activation of DMPMBA and its conjugation to PEG-amine to form self-assembling micelles.

Detailed Procedure:

- Activation:
 - Dissolve DMPMBA (1.2 eq) in anhydrous DCM.
 - Add EDC.HCl (1.5 eq) and NHS (1.5 eq). Stir at 0°C for 1 hour, then warm to RT for 2 hours.
 - Checkpoint: Formation of the NHS-ester can be verified by TLC or IR (shift of carbonyl peak).
- Conjugation:
 - Add

(Molecular Weight 2000–5000 Da, 1.0 eq) and Triethylamine (TEA, 2.0 eq) to the reaction mixture.
 - Stir at Room Temperature for 24 hours under Nitrogen.
- Purification:
 - Precipitate the polymer into cold Diethyl Ether (10x volume).
 - Filter and redissolve in water.
 - Dialysis: Dialyze against distilled water (MWCO 1000 Da) for 48 hours to remove unreacted small molecules.
 - Lyophilize to obtain the white powder product.

Characterization & Validation

To ensure scientific integrity, the following data points must be verified:

Technique	Diagnostic Signal	Purpose
1H-NMR (DMSO-d6)	2.2 ppm (s, 6H, -CH3) 5.1 ppm (s, 2H, -CH2-O-) 3.6 ppm (PEG backbone)	Confirm conjugation ratio and structure integrity. The integration ratio of the methyl protons (2.2 ppm) to PEG protons confirms the Degree of Substitution (DS).
GPC (Gel Permeation)	Shift to higher MW; Monomodal peak.	Verify absence of free DMPMBA and cross-linking.
DSC	Shift in or .	Assess effect of the bulky end-group on crystallinity.
CMC Determination	Fluorescence spectroscopy (Pyrene probe).	Determine the concentration at which micelles form (critical for drug delivery).

References

- Williamson Ether Synthesis Principles
 - Smith, M. B., & March, J. (2007). March's Advanced Organic Chemistry: Reactions, Mechanisms, and Structure. Wiley-Interscience.
- Polymer End-Capping Strategies
 - Gauthier, M. A., & Gibson, M. I. (2010). Synthesis of Functional Polymers by Post-Polymerization Modification. Angewandte Chemie International Edition.
- Phenoxyethyl Benzoic Acid Derivatives in Liquid Crystals
 - Imrie, C. T., et al. (1994). Liquid Crystalline Polymers Containing Phenoxyethyl Benzoate Mesogens. Macromolecules. (Cited as general structural analogue reference).
- PEGylation for Drug Delivery

- Veronese, F. M., & Pasut, G. (2005). PEGylation, successful approach to drug delivery. Drug Discovery Today.
- To cite this document: BenchChem. [Using 4-[(3,5-dimethylphenoxy)methyl]benzoic acid as a polymer intermediate]. BenchChem, [2026]. [Online PDF]. Available at: [<https://www.benchchem.com/product/b3104703/docs#using-4-3-5-dimethylphenoxy-methyl-benzoic-acid-as-a-polymer-intermediate>]

Disclaimer & Data Validity:

The information provided in this document is for Research Use Only (RUO) and is strictly not intended for diagnostic or therapeutic procedures. While BenchChem strives to provide accurate protocols, we make no warranties, express or implied, regarding the fitness of this product for every specific experimental setup.

Technical Support: The protocols provided are for reference purposes. Unsure if this reagent suits your experiment?

Need Industrial/Bulk Grade? [Request Custom Synthesis Quote](#)

BenchChem

Our mission is to be the trusted global source of essential and advanced chemicals, empowering scientists and researchers to drive progress in science and industry.

Contact

Address: 3281 E Guasti Rd
Ontario, CA 91761, United States
Phone: (601) 213-4426
Email: info@benchchem.com

[Contact our Ph.D. Support Team for a compatibility check](#)

