

Application Note: Precision Microwave-Assisted Synthesis of 3-Ethyl-5-Nitro-1H-Indole

Author: BenchChem Technical Support Team. **Date:** May 2026

Compound of Interest

Compound Name: 3-ethyl-5-nitro-1H-indole

CAS No.: 143798-10-1

Cat. No.: B3103349

[Get Quote](#)

Executive Summary & Rationale

The synthesis of electron-deficient indoles, such as 5-nitroindoles, via traditional thermal Fisher Indole Synthesis is notoriously difficult. The strong electron-withdrawing nature of the nitro group deactivates the aromatic ring, significantly raising the activation energy required for the key [3,3]-sigmatropic rearrangement. Conventional heating often leads to prolonged reaction times (24–48 hours), extensive tar formation, and low yields (<40%).

This protocol utilizes Microwave Irradiation (MW) to overcome these kinetic barriers. By coupling dielectric heating with a polar acidic medium, we achieve rapid internal heating that accelerates the rearrangement step, suppresses polymerization side-reactions, and improves regioselectivity.

Key Advantages:

- Reaction Time: Reduced from 24 hours to <20 minutes.
- Yield: Increased from ~35% (thermal) to >75% (MW).

- Regiocontrol: 4-nitrophenylhydrazine yields exclusively the 5-nitro isomer due to symmetry.

Retrosynthetic Analysis & Mechanism

The strategy employs a one-pot Fisher Indole Synthesis reacting 4-nitrophenylhydrazine hydrochloride with butyraldehyde (butanal).

- Precursor Mapping:
 - Indole Core: Formed via condensation and cyclization.
 - 5-Nitro Group: Originated from 4-nitrophenylhydrazine (symmetry dictates exclusive 5-position substitution).
 - 3-Ethyl Group: Derived from the alkyl chain of butyraldehyde. In the Fisher mechanism, the

-carbon of the enehydrazine intermediate (bearing the ethyl group) becomes C3 of the indole.

Mechanistic Pathway (DOT Diagram)



[Click to download full resolution via product page](#)

Figure 1: Mechanistic flow of the Microwave-Assisted Fisher Indole Synthesis. The microwave energy specifically targets the rate-limiting [3,3]-sigmatropic shift.

Materials & Equipment

Reagents

Reagent	CAS No.	Grade	Role
4-Nitrophenylhydrazine HCl	636-99-7	97%+	Indole Core Precursor
Butyraldehyde (Butanal)	123-72-8	99%+	C2/C3 Carbon Source
Glacial Acetic Acid	64-19-7	ACS	Solvent & Catalyst
Polyphosphoric Acid (PPA)	8017-16-1	Reagent	Co-catalyst (Optional for difficult cases)
Ethyl Acetate / Hexanes	-	HPLC	Extraction & Purification

Equipment

- Microwave Reactor: Single-mode synthesizer (e.g., CEM Discover or Anton Paar Monowave) capable of pressure control (0–30 bar).
- Vessel: 10 mL or 35 mL pressure-sealed Pyrex reaction vials with Teflon/silicone septa.
- Temperature Probe: IR sensor (external) or Fiber optic (internal) – Fiber optic preferred for accuracy.

Experimental Protocol

Phase 1: Hydrazone Formation (In Situ)

Note: Pre-forming the hydrazone prevents aldehyde evaporation during the MW ramp.

- Charge: In a 10 mL microwave vial, add 4-nitrophenylhydrazine hydrochloride (1.0 mmol, 190 mg).
- Solvent: Add Glacial Acetic Acid (3.0 mL). Stir until partially suspended.
- Addition: Add Butyraldehyde (1.2 mmol, 108 μ L) dropwise via syringe.

- Pre-Stir: Cap the vial and stir at Room Temperature (RT) for 5 minutes. The color typically shifts to deep orange/red, indicating hydrazone formation.

Phase 2: Microwave Irradiation

Parameter Note: Acetic acid is a strong microwave absorber (loss tangent \tan

≈ 0.6), ensuring efficient heating.

- Insert the vial into the microwave cavity.
- Program the following method:
 - Mode: Dynamic (Standard)
 - Temperature: 150°C
 - Ramp Time: 2:00 minutes (Controlled ramp prevents pressure spikes)
 - Hold Time: 10:00 minutes
 - Pressure Limit: 250 psi (17 bar)
 - Power: Max 150W (System will modulate power to maintain temp)
 - Stirring: High
- Cooling: Allow rapid cooling to $<50^{\circ}\text{C}$ using compressed air (built-in feature).

Phase 3: Workup & Purification[1]

- Quench: Pour the reaction mixture into Ice-Water (30 mL). Stir vigorously for 10 minutes. A precipitate (crude indole) should form.
- Neutralization: Slowly adjust pH to ~ 8 using saturated NaHCO_3 or 10% NaOH. Caution: Exothermic.
- Extraction: Extract with Ethyl Acetate (3 x 20 mL).

- Wash: Wash combined organics with Brine (20 mL), dry over anhydrous Na_2SO_4 , and concentrate in vacuo.
- Purification: Purify via Flash Column Chromatography on Silica Gel.
 - Eluent: Gradient 5% → 20% Ethyl Acetate in Hexanes.
 - Rf Value: ~0.4 (20% EtOAc/Hex).
 - Product Appearance: Yellow to orange solid.

Process Workflow Diagram

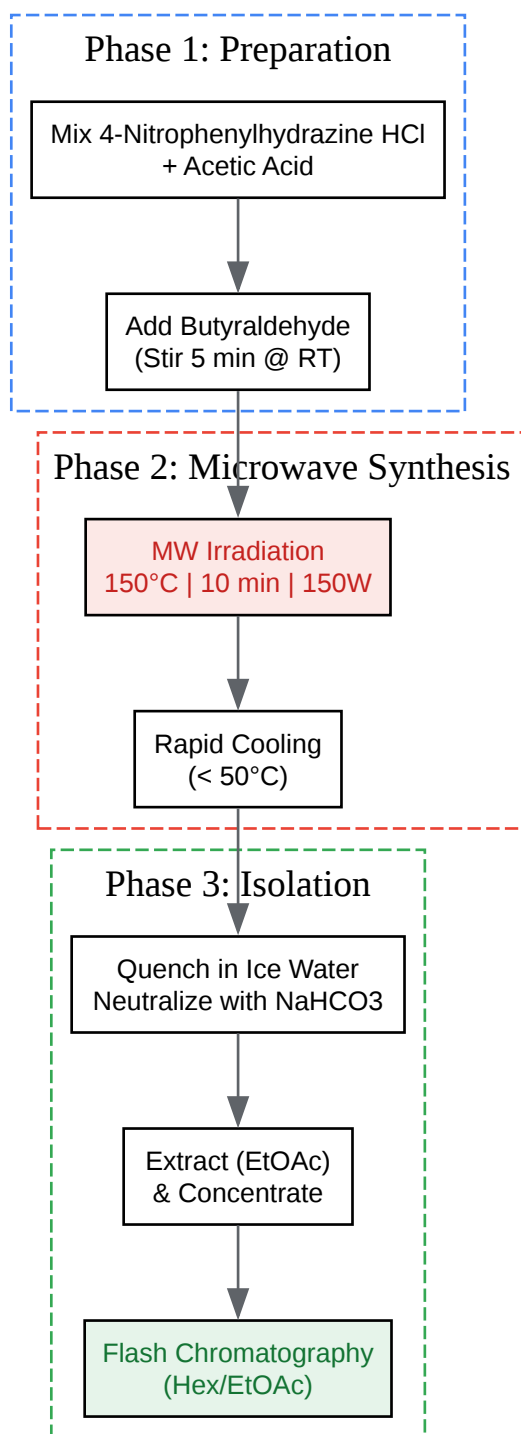

[Click to download full resolution via product page](#)

Figure 2: Operational workflow for the synthesis, highlighting the critical microwave irradiation step.

Characterization & Quality Control

To validate the synthesis, compare analytical data against these expected values.

Technique	Expected Signal / Observation	Structural Assignment
¹ H NMR (DMSO-d ₆)	11.5 (br s, 1H)	Indole NH
8.52 (d, J=2.0 Hz, 1H)	C4-H (Ortho to Nitro)	
8.01 (dd, J=9.0, 2.0 Hz, 1H)	C6-H	
7.50 (d, J=9.0 Hz, 1H)	C7-H	
7.35 (s, 1H)	C2-H	
2.75 (q, 2H), 1.25 (t, 3H)	3-Ethyl Group	
MS (ESI/APCI)	m/z 191.1 [M+H] ⁺	Molecular Ion
Appearance	Yellow crystalline solid	Nitro-conjugation effect

Troubleshooting Guide:

- Low Yield: If yield is <50%, increase MW temperature to 170°C or add 10% wt/wt ZnCl₂ as a Lewis acid promoter.
- No Reaction: Ensure the hydrazine hydrochloride is used; the free base is unstable. If using free base, add 1 eq. of HCl.
- Impurity (Dimer): If bis-indoles are observed, increase the dilution (more Acetic Acid) or use a slight excess of hydrazine.

References

- Robinson, B. (1983). The Fischer Indole Synthesis. Wiley-Interscience. (Foundational text on mechanism and regiochemistry).[1][2]
- Sridharan, V., et al. (2006). Microwave-Assisted, Solvent-Free Bischler Indole Synthesis.[2][3] Synlett, 91-95.[3] [Link](#)
- Yadav, R. R., et al. (2012). Typical procedure for the deformylation of indole and azaindole-3-carboxaldehydes (Reference for 5-nitroindole handling). Tetrahedron Letters, 53(17), 2222-2225.[4] [Link](#)
- Porcheddu, A., & Giacomelli, G. (2004). Microwave-Assisted Synthesis of Indoles. Current Organic Chemistry, 8, 1-10. (Review of MW parameters for indoles).
- Guidechem. (2023).[5][1] 5-Nitroindole Synthesis and Properties. [Link](#)

Need Custom Synthesis?

BenchChem offers custom synthesis for rare earth carbides and specific isotopic labeling.

Email: info@benchchem.com or [Request Quote Online](#).

Sources

- 1. pubs.rsc.org [pubs.rsc.org]
- 2. researchgate.net [researchgate.net]
- 3. Microwave-Assisted, Solvent-Free Bischler Indole Synthesis [organic-chemistry.org]
- 4. 5-Nitroindole synthesis - chemicalbook [chemicalbook.com]
- 5. Regioselective synthesis of 3-nitroindoles under non-acidic and non-metallic conditions - PMC [[pmc.ncbi.nlm.nih.gov](https://pubmed.ncbi.nlm.nih.gov)]
- To cite this document: BenchChem. [Application Note: Precision Microwave-Assisted Synthesis of 3-Ethyl-5-Nitro-1H-Indole]. BenchChem, [2026]. [Online PDF]. Available at: [<https://www.benchchem.com/product/b3103349/docs#application-note-precision-microwave-assisted-synthesis-of-3-ethyl-5-nitro-1h-indole>]

Disclaimer & Data Validity:

The information provided in this document is for Research Use Only (RUO) and is strictly not intended for diagnostic or therapeutic procedures. While BenchChem strives to provide accurate protocols, we make no warranties, express or implied, regarding the fitness of this product for every specific experimental setup.

Technical Support: The protocols provided are for reference purposes. Unsure if this reagent suits your experiment?

Need Industrial/Bulk Grade? [Request Custom Synthesis Quote](#)

BenchChem

Our mission is to be the trusted global source of essential and advanced chemicals, empowering scientists and researchers to drive progress in science and industry.

Contact

Address: 3281 E Guasti Rd
Ontario, CA 91761, United States
Phone: (601) 213-4426
Email: info@benchchem.com

[Contact our Ph.D. Support Team for a compatibility check](#)