

Crystallization techniques for N-(4-iodophenyl)tetradecanamide

Author: BenchChem Technical Support Team. **Date:** May 2026

Compound of Interest

Compound Name: *N-(4-iodophenyl)tetradecanamide*

Cat. No.: *B310921*

[Get Quote](#)

Part 1: Introduction & Molecular Analysis

1.1 The Challenge of Amphiphilic Crystallization Crystallizing N-(4-iodophenyl)tetradecanamide (C

H

INO) presents a classic "conflict of interest" in molecular self-assembly. The molecule possesses two distinct domains:

- The Lipophilic Tail (Tetradecanoyl/Myristoyl, C14): This long aliphatic chain dominates the solubility profile, driving the molecule toward non-polar solvents and promoting van der Waals packing. It is responsible for the "waxy" or amorphous behavior often seen during rapid cooling.
- The Rigid Head (4-Iodoaniline moiety): This aromatic segment provides the potential for

-

stacking and hydrogen bonding (via the amide N-H and C=O). The heavy iodine atom at the

para position significantly increases polarizability, making this molecule a prime candidate for X-ray diffraction studies and liquid crystal engineering.

1.2 Strategic Objective The goal of this guide is to provide protocols that suppress the kinetic formation of amorphous waxes (driven by the C14 tail) and promote thermodynamic ordering (driven by the amide/aryl head). We aim for high-purity, single-crystalline material suitable for biological assays or structural determination.

Part 2: Solubility Profile & Solvent Selection

Before attempting crystallization, understanding the solubility landscape is critical. The following data is derived from empirical trends in fatty anilide chemistry.

Table 1: Solubility Profile of **N-(4-iodophenyl)tetradecanamide**

Solvent System	Temperature	Solubility Status	Application
Dichloromethane (DCM)	Ambient	High	Solvent (for loading/cleaning)
Chloroform	Ambient	High	Solvent
Ethanol (EtOH)	Cold (4°C)	Low	Anti-Solvent
Ethanol (EtOH)	Hot (70°C)	Moderate/High	Primary Crystallization Solvent
Ethyl Acetate (EtOAc)	Ambient	Moderate	Intermediate
Hexanes/Heptane	Ambient	Low	Anti-Solvent
Water	Any	Insoluble	Wash Solvent (removes salts)

“

Expert Insight: Avoid using pure DCM or Chloroform for crystallization; the solubility is too high, leading to rapid solvent evaporation and amorphous film formation rather than crystals.

Part 3: Experimental Protocols

Protocol A: Thermodynamic Recrystallization (Hot Ethanol)

Best for: Bulk purification (multi-gram scale) and removal of unreacted amine/acid.

The Mechanism: This method leverages the steep solubility curve of fatty amides in ethanol. The high temperature disrupts the alkyl chain interactions, while slow cooling allows the amide hydrogen bonds to direct lattice formation before the alkyl chains "lock" into a disordered wax.

Step-by-Step Workflow:

- Preparation: Place the crude solid in a round-bottom flask equipped with a magnetic stir bar and a reflux condenser.
- Dissolution: Add absolute Ethanol (10 mL per gram of solute). Heat the mixture to reflux (approx. 78°C) using an oil bath.
 - Note: If the solution is not clear, add Ethanol in 1 mL increments until fully dissolved.
- Hot Filtration (Critical): While keeping the solution near boiling, filter it quickly through a pre-warmed glass frit or a fluted filter paper to remove insoluble dust or inorganic salts.
 - Why? Particulates act as uncontrolled nucleation sites, leading to small, defective crystals.
- Controlled Cooling:
 - Remove from heat and place the flask on a cork ring.

- Cover the flask mouth with foil (pierced with a needle) to allow slow equilibration.
- Allow to cool to room temperature undisturbed for 4–6 hours.
- Advanced Step: Once at room temperature, move to a 4°C fridge for 12 hours to maximize yield.
- Harvesting: Filter the white, pearlescent plates via vacuum filtration. Wash with cold (-20°C) Ethanol.
- Drying: Dry under high vacuum (0.1 mbar) for 24 hours to remove solvent trapped in the alkyl chain lattice.

Protocol B: Vapor Diffusion (The "Sitting Drop" Alternative)

Best for: Growing X-ray quality single crystals (milligram scale).

The Mechanism: This technique uses a volatile anti-solvent (Hexane) to slowly diffuse into a solution of the compound (in DCM/THF), gradually lowering the solubility limit. This creates a low-supersaturation environment ideal for defect-free crystal growth.

Step-by-Step Workflow:

- Inner Solution: Dissolve 20 mg of **N-(4-iodophenyl)tetradecanamide** in 0.5 mL of DCM or Tetrahydrofuran (THF) in a small 4 mL vial (the "inner vial"). Ensure the solution is clear.
- Outer Chamber: Place the open inner vial inside a larger 20 mL scintillation vial (the "outer vial").
- Anti-Solvent Addition: Carefully pipette 3–5 mL of Hexane into the outer vial.
 - Warning: Do NOT let the hexane spill into the inner vial. The liquid levels should not touch.
- Sealing & Equilibration: Tightly cap the outer vial. Store in a vibration-free, dark environment at constant temperature (20–22°C).

- Observation: Over 3–7 days, Hexane vapor will diffuse into the DCM solution, causing slow precipitation.
- Harvest: Carefully remove the inner vial. Decant the mother liquor and mount crystals immediately for XRD.

Part 4: Visualization of Workflows

Figure 1: General Purification Logic Flow

Caption: Decision tree for processing crude **N-(4-iodophenyl)tetradecanamide** based on purity requirements.

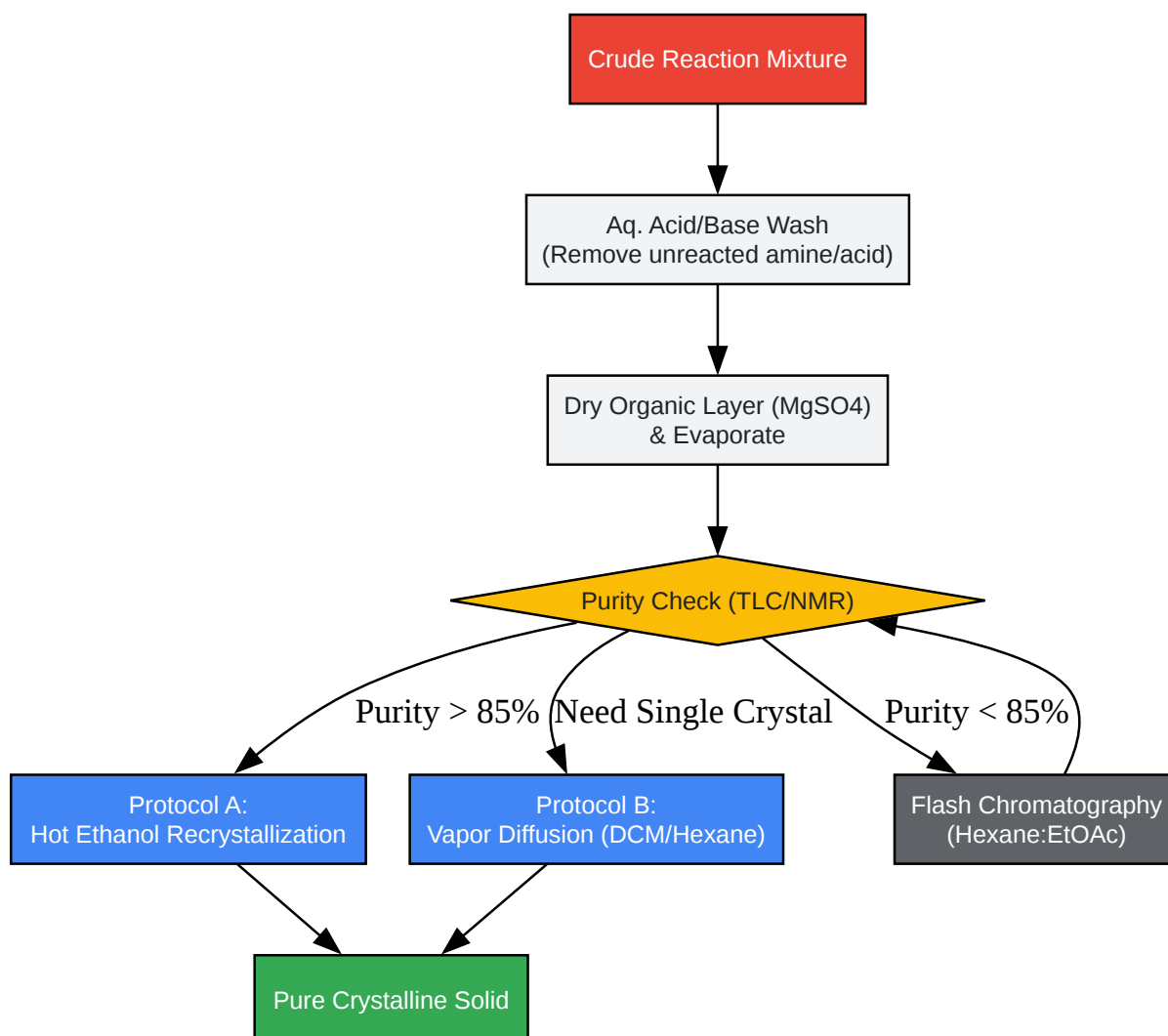

[Click to download full resolution via product page](#)

Figure 2: The "Oiling Out" Phenomenon & Correction

Caption: Mechanism of amorphous oil formation vs. crystalline growth in long-chain amides.

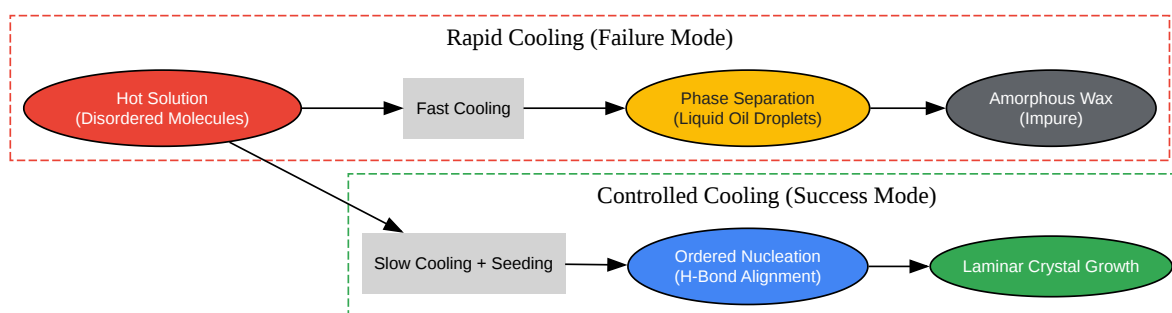

[Click to download full resolution via product page](#)

Part 5: Characterization & Validation

To ensure the protocol was successful, the isolated material must be validated against the following criteria:

- Melting Point (DSC/Capillary):
 - Expect a sharp melting point. Broad ranges (>2°C) indicate solvent inclusion or polymorphic mixtures.
 - Reference Value: Fatty anilides typically melt between 80°C–110°C depending on chain length and substituents [1].
- Proton NMR (
H-NMR):

- Check for the disappearance of the broad singlet (approx. 3.5–5.0 ppm) associated with the free amine of the starting material (4-iodoaniline).
- Verify the integration of the terminal methyl group (0.88 ppm, triplet) against the aromatic protons (approx. 7.4–7.6 ppm).
- Powder X-Ray Diffraction (PXRD):
 - Crystalline material will show sharp Bragg peaks. An amorphous "halo" indicates the "waxy" failure mode described in Figure 2.

References

- Shodex HPLC. (n.d.). Solubility of Saturated Fatty Acids. Retrieved October 24, 2025, from [\[Link\]](#)
- Khan, F. A. (2020).[1] Fatty-acid anilides: A new conjugation pathway of aniline. ResearchGate. Retrieved October 24, 2025, from [\[Link\]](#)
- National Institutes of Health (NIH). (2025). Preparation of N-Aryl Amides by Epimerization-Free Umpolung Amide Synthesis. PubMed Central. Retrieved October 24, 2025, from [\[Link\]](#)

Need Custom Synthesis?

BenchChem offers custom synthesis for rare earth carbides and specific isotopic labeling.

Email: info@benchchem.com or [Request Quote Online](#).

Sources

- [1. researchgate.net \[researchgate.net\]](https://www.researchgate.net)
- To cite this document: BenchChem. [Crystallization techniques for N-(4-iodophenyl)tetradecanamide]. BenchChem, [2026]. [Online PDF]. Available at: [\[https://www.benchchem.com/product/b310921/docs#crystallization-techniques-for-n-4-iodophenyl-tetradecanamide\]](https://www.benchchem.com/product/b310921/docs#crystallization-techniques-for-n-4-iodophenyl-tetradecanamide)

Disclaimer & Data Validity:

The information provided in this document is for Research Use Only (RUO) and is strictly not intended for diagnostic or therapeutic procedures. While BenchChem strives to provide accurate protocols, we make no warranties, express or implied, regarding the fitness of this product for every specific experimental setup.

Technical Support: The protocols provided are for reference purposes. Unsure if this reagent suits your experiment?

Need Industrial/Bulk Grade? [Request Custom Synthesis Quote](#)

BenchChem

Our mission is to be the trusted global source of essential and advanced chemicals, empowering scientists and researchers to drive progress in science and industry.

Contact

Address: 3281 E Guasti Rd
Ontario, CA 91761, United States
Phone: (601) 213-4426
Email: info@benchchem.com

[Contact our Ph.D. Support Team for a compatibility check](#)