

Technical Support Center: Improving Regioselectivity in Pyrazole Synthesis

Author: BenchChem Technical Support Team. **Date:** May 2026

Compound of Interest

Compound Name:	3-cyano-1H-pyrazole-5-carboxylic acid
CAS No.:	1187361-13-2
Cat. No.:	B1592806

[Get Quote](#)

Welcome to the technical support guide for researchers, scientists, and drug development professionals. This document addresses one of the most persistent challenges in the synthesis of N-substituted pyrazoles: controlling regioselectivity. The formation of regioisomeric mixtures not only complicates purification but also reduces the overall yield of the desired active compound, a critical issue in medicinal chemistry and materials science.[1][2] This guide provides in-depth, field-tested answers and protocols to help you troubleshoot and optimize your synthetic strategies.

Part 1: Frequently Asked Questions (FAQs)

This section addresses fundamental questions regarding regioselectivity in the context of pyrazole synthesis.

Q1: What exactly is regioselectivity in pyrazole synthesis, and why is it a critical problem?

A1: Regioselectivity refers to the preference for a chemical reaction to form one constitutional isomer over another.[3] In the classic Knorr synthesis of pyrazoles, the reaction between an

unsymmetrical 1,3-dicarbonyl compound and a substituted hydrazine can proceed via two different pathways.[3][4][5] The substituted hydrazine can attack either of the two non-equivalent carbonyl groups, leading to a mixture of two regioisomeric pyrazoles (e.g., 1,3,5- and 1,3,4-trisubstituted products).[3]

This is a critical issue because different regioisomers often possess vastly different biological activities, pharmacological profiles, and physical properties.[1] For drug development, producing a specific, single isomer is often a regulatory requirement. A non-selective reaction leads to difficult-to-separate mixtures, reducing the effective yield and increasing downstream processing costs.[3][6]

Q2: What are the primary factors that control the regiochemical outcome of the reaction?

A2: The regioselectivity of the condensation reaction is a delicate balance of several interconnected factors related to the reactants and the reaction environment.[2][3][4]

- **Electronic Effects:** This is often the dominant factor. The initial nucleophilic attack by a nitrogen atom of the hydrazine typically occurs at the more electrophilic (electron-poor) carbonyl carbon of the 1,3-dicarbonyl compound.[1][3] For instance, a carbonyl group adjacent to a strong electron-withdrawing group (like $-CF_3$) is significantly more reactive toward nucleophilic attack than one next to an alkyl or aryl group.[1][7]
- **Steric Effects:** Bulky substituents on either the 1,3-dicarbonyl or the hydrazine can physically block the approach of the nucleophile.[2][3] The reaction will, therefore, favor the attack at the less sterically hindered carbonyl group.
- **Reaction Conditions:** This is the most common area for optimization.
 - **Solvent:** The choice of solvent can dramatically alter the regiochemical outcome. As will be discussed, highly polar, hydrogen-bond-donating solvents like fluorinated alcohols can stabilize intermediates selectively and drastically improve regioselectivity.[6][7]
 - **pH (Acid/Base Catalysis):** The acidity or basicity of the medium is crucial.[3][4] Under acidic conditions, the relative nucleophilicity of the two nitrogen atoms in the substituted hydrazine can be altered. For methylhydrazine, the NH_2 group is generally more nucleophilic. For arylhydrazines, resonance effects can decrease the nucleophilicity of the secondary nitrogen, but protonation can change this balance.[8][9]

Q3: How can I reliably determine the structure and isomeric ratio of my product mixture?

A3: A combination of chromatographic and spectroscopic techniques is essential for both quantifying the isomeric ratio and unambiguously assigning the structure of each regioisomer.

- Initial Assessment (TLC/LC-MS): Thin-Layer Chromatography (TLC) can often show two distinct spots if the isomers have different polarities. Liquid Chromatography-Mass Spectrometry (LC-MS) will confirm that both components have the same mass, strongly suggesting they are isomers.
- Separation (Column Chromatography): Flash column chromatography is the standard method for separating regioisomers on a preparative scale.[\[10\]](#)[\[11\]](#)[\[12\]](#)
- Structural Elucidation (NMR Spectroscopy): This is the definitive method.
 - ^1H and ^{13}C NMR: Each pure isomer will give a distinct set of peaks. Comparing the chemical shifts, particularly of the pyrazole ring protons and carbons, provides the first clues.[\[13\]](#)
 - Nuclear Overhauser Effect Spectroscopy (NOESY): This 2D NMR experiment is the gold standard for confirming assignments.[\[10\]](#)[\[14\]](#) It detects spatial proximity between protons. For example, a NOESY cross-peak between the protons of the N-substituent (e.g., N-CH₃) and the protons of the substituent at the C5 position confirms that these groups are on adjacent atoms, thus identifying the isomer.[\[14\]](#)

Part 2: Troubleshooting Guide

This section provides direct solutions to common experimental problems.

Issue 1: My reaction produces a nearly 1:1 mixture of regioisomers.

This is a frequent outcome when the electronic and steric differences between the two carbonyl groups are minimal.[\[1\]](#) In this scenario, the most effective strategy is to modify the reaction conditions to amplify any subtle differences in reactivity.

Solution: Change the Solvent System.

The choice of solvent is arguably the most powerful tool for enhancing regioselectivity without redesigning the substrates. While ethanol is a conventional solvent for this reaction, it often provides poor selectivity.[6]

Primary Recommendation: Switch to a fluorinated alcohol solvent, such as 2,2,2-trifluoroethanol (TFE) or 1,1,1,3,3,3-hexafluoro-2-propanol (HFIP).[6][7]

Causality: Fluorinated alcohols are strong hydrogen-bond donors but poor hydrogen-bond acceptors.[7] They can selectively form a hemiketal intermediate with the more reactive carbonyl group (e.g., the one adjacent to a $-CF_3$ group). This effectively "protects" one carbonyl, directing the hydrazine to attack the other, thereby dramatically increasing the regioselectivity of the cyclization.[7]

See Table 1 for a quantitative comparison and Protocol 1 for a detailed experimental procedure.

Issue 2: The major product of my reaction is the undesired regioisomer.

This occurs when the intrinsic electronic and steric properties of your substrates favor the formation of the unwanted product under standard conditions.[1] To reverse this, you must alter the fundamental factors governing the initial nucleophilic attack.

Solution 1: Modify the Reaction pH.

The nucleophilicity of the two nitrogen atoms in a substituted hydrazine is pH-dependent. The generally accepted mechanism posits that the more nucleophilic nitrogen attacks the more electrophilic carbonyl.[3][8]

- For Alkylhydrazines (e.g., Methylhydrazine): The terminal $-NH_2$ group is typically more nucleophilic.
- For Arylhydrazines (e.g., Phenylhydrazine): The lone pair on the nitrogen attached to the aryl ring is delocalized, making the terminal $-NH_2$ group more nucleophilic.[8][9]

By switching from neutral/basic conditions to acidic conditions (e.g., using catalytic acetic or sulfuric acid), you can protonate the hydrazines.[5][15] This can alter the relative nucleophilicity

of the two nitrogen atoms, potentially reversing the site of initial attack and changing the major regioisomer formed.

Solution 2: Redesign the Synthetic Precursor (If Feasible).

If reaction conditions cannot solve the problem, a substrate redesign may be necessary.

- Change the Hydrazine: Using a hydrazine with a different substituent (e.g., switching from methylhydrazine to phenylhydrazine, or using a hydrazine with a bulky group like tert-butylhydrazine) can alter both electronic and steric influences.^[2]
- Use an Alternative Synthetic Route: Consider methods that offer inherent regiocontrol, such as those starting from α,β -unsaturated ketones or multicomponent reactions designed for regioselectivity.^{[8][9][16][17]} Another powerful strategy involves the [3+2] cycloaddition of sydnone with functionalized alkynes, which can offer excellent regiocontrol under specific catalytic conditions.^[18]

Issue 3: I am struggling to separate the regioisomers.

When regioisomers have very similar polarities, they co-elute during standard column chromatography, making separation difficult.

Solution 1: Optimize Column Chromatography.

- Stationary Phase: If silica gel fails, try a different stationary phase like alumina (basic or neutral) or reversed-phase silica (C18).^[11]
- Eluent System: Meticulously screen different solvent systems. Use a shallow gradient of a more polar solvent in a less polar one (e.g., 0-10% ethyl acetate in hexanes) to maximize separation. Adding a small amount of a third solvent (e.g., dichloromethane or a trace of triethylamine for basic compounds) can sometimes improve resolution.
- Technique: Use a high-quality silica gel with a small particle size and a longer column to increase the number of theoretical plates.

Solution 2: Attempt Fractional Recrystallization.

If the product is a solid, fractional recrystallization can be a powerful, scalable alternative to chromatography.^[11] This technique relies on small differences in the solubility of the isomers in a given solvent system. Experiment with a wide range of solvents of varying polarities.

Solution 3: Derivatization.

In challenging cases, you can chemically modify the isomer mixture. Introduce a functional group that significantly alters the polarity or properties of one isomer over the other, allowing for easy separation. After separation, the directing group is cleaved to yield the pure, desired regioisomer.^[11]

Part 3: Key Experimental Protocols

Protocol 1: Improving Regioselectivity using Fluorinated Alcohols

This protocol is adapted from methodologies proven to enhance regioselectivity in the synthesis of pyrazoles from fluorinated 1,3-diketones.^{[7][19]}

- Materials:
 - Unsymmetrical 1,3-diketone (1.0 eq)
 - Substituted hydrazine (e.g., methylhydrazine) (1.1 eq)
 - Solvent: 2,2,2-Trifluoroethanol (TFE) or 1,1,1,3,3,3-Hexafluoro-2-propanol (HFIP)
 - Round-bottom flask, magnetic stirrer, and reflux condenser
- Procedure:
 - Reaction Setup: In a round-bottom flask, dissolve the 1,3-diketone (1.0 eq) in TFE or HFIP (approx. 0.1–0.2 M concentration).
 - Hydrazine Addition: Add the substituted hydrazine (1.1 eq) to the solution at room temperature while stirring. The addition can be done dropwise if the reaction is exothermic.

- Reaction: Stir the mixture at room temperature or heat to reflux if necessary. Monitor the reaction's progress by TLC or LC-MS until the starting diketone is consumed (typically 1-24 hours).
- Work-up: Cool the reaction mixture to room temperature. Remove the fluorinated solvent under reduced pressure using a rotary evaporator.
- Extraction: Dilute the residue with a suitable organic solvent (e.g., ethyl acetate) and wash sequentially with water and brine.
- Drying and Concentration: Dry the organic layer over anhydrous sodium sulfate (Na_2SO_4), filter, and concentrate in vacuo to obtain the crude product.
- Analysis and Purification: Determine the isomeric ratio of the crude product using ^1H NMR. Purify the major regioisomer by column chromatography or recrystallization.

Protocol 2: General Method for Separation of Pyrazole Regioisomers by Column Chromatography

This protocol provides a general workflow for separating a mixture of two pyrazole regioisomers.[\[10\]](#)[\[11\]](#)[\[19\]](#)

- Materials:
 - Crude mixture of pyrazole regioisomers
 - Silica gel for flash chromatography (e.g., 230-400 mesh)
 - Eluent system (e.g., Hexanes/Ethyl Acetate)
 - TLC plates, chromatography column, and collection tubes
- Procedure:
 - Determine Eluent System: Using TLC, test various solvent systems to find one that provides good separation (a difference in R_f values, ΔR_f , of at least 0.1 is ideal). Start with a low polarity mixture (e.g., 95:5 Hexanes:EtOAc) and gradually increase the polarity.

- Prepare the Column: Pack a glass column with silica gel as a slurry in the initial, low-polarity eluent. Ensure the packing is uniform and free of air bubbles.
- Load the Sample: Dissolve the crude mixture in a minimal amount of the eluent or a stronger solvent like dichloromethane. Alternatively, perform a "dry loading" by adsorbing the sample onto a small amount of silica gel, evaporating the solvent, and carefully adding the resulting powder to the top of the column.
- Elution: Begin eluting the column with the low-polarity solvent system. Collect fractions and monitor them by TLC. You can run the separation isocratically (with a single solvent mixture) or by using a gradient (gradually increasing the polarity of the eluent).
- Combine and Concentrate: Combine the fractions containing each pure isomer (as determined by TLC). Remove the solvent under reduced pressure to yield the isolated, pure regioisomers.
- Confirm Purity: Assess the purity of each isolated isomer using ^1H NMR.

Part 4: Visualization & Data

Data Presentation

Table 1: Effect of Solvent on the Regioselectivity of Pyrazole Synthesis

The following data illustrates the powerful effect of solvent choice on the reaction of 1-(Aryl)-4,4,4-trifluorobutane-1,3-dione with a substituted hydrazine. The desired isomer is typically the one with the aryl group at the 5-position.^{[6][7]}

1,3-Diketone (R ¹)	Hydrazine	Solvent	Isomer Ratio (5-Aryl : 3-Aryl)	Total Yield (%)	Reference
1-Phenyl-4,4,4-trifluoro...	Methylhydrazine	EtOH	55 : 45	85%	[7]
1-Phenyl-4,4,4-trifluoro...	Methylhydrazine	TFE	97 : 3	90%	[7]
1-Phenyl-4,4,4-trifluoro...	Methylhydrazine	HFIP	>99 : 1	92%	[7]
1-(2-Furyl)-4,4,4-trifluoro...	Methylhydrazine	EtOH	15 : 85	75%	[7]
1-(2-Furyl)-4,4,4-trifluoro...	Methylhydrazine	TFE	85 : 15	88%	[7]
1-(2-Furyl)-4,4,4-trifluoro...	Methylhydrazine	HFIP	97 : 3	95%	[7]

Data is representative and compiled from published results. Ratios and yields may vary with specific substrates and conditions.

Experimental & Logical Workflows

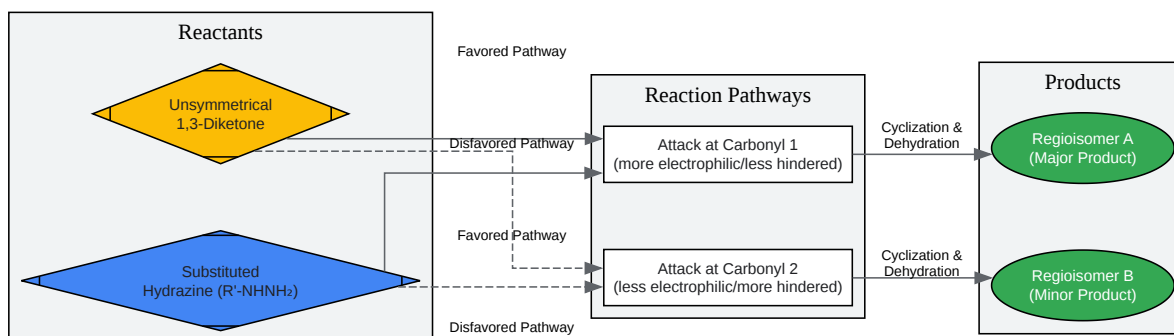

[Click to download full resolution via product page](#)

Caption: Knorr synthesis pathway leading to two regioisomers.

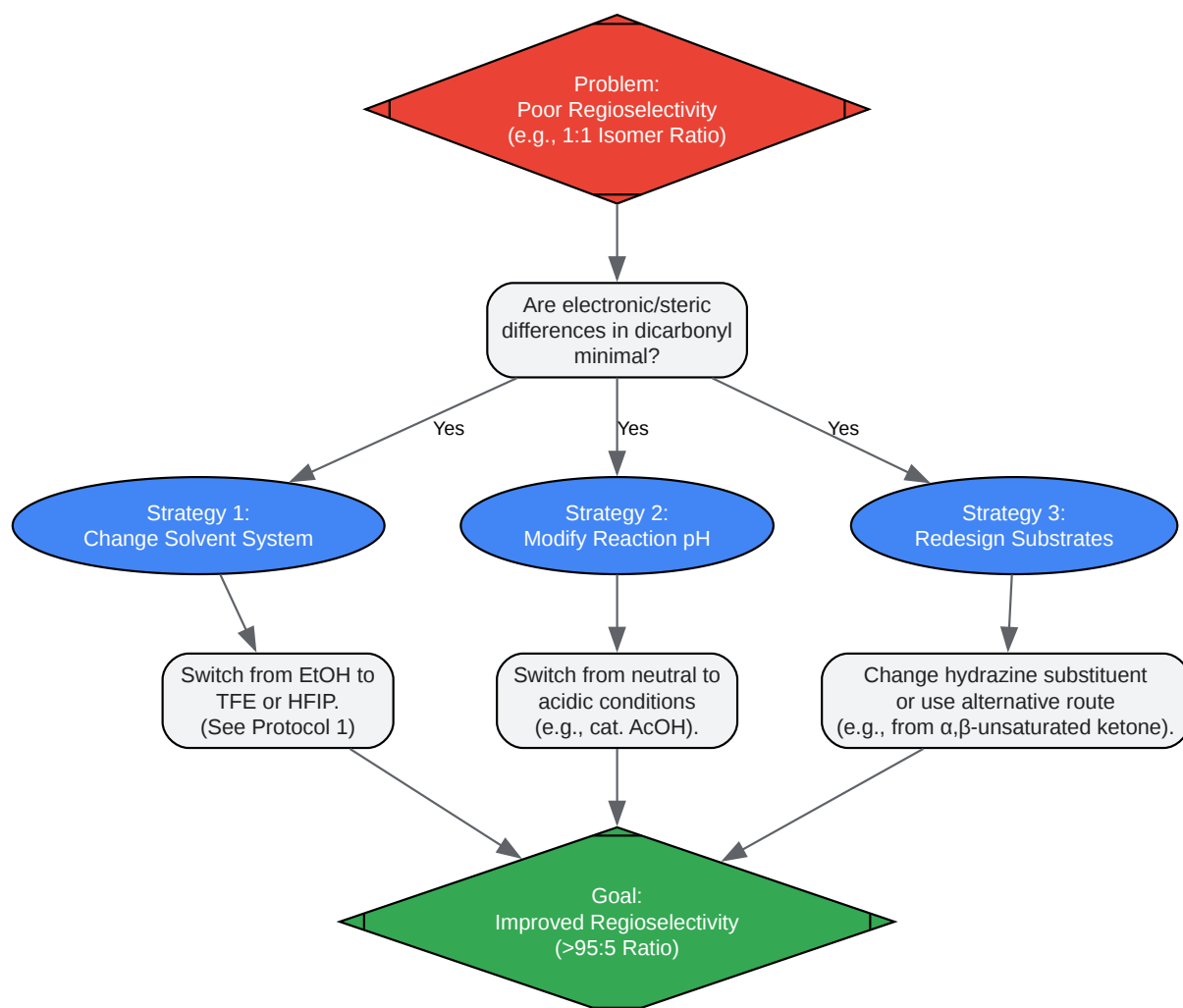

[Click to download full resolution via product page](#)

Caption: Decision-making workflow for improving regioselectivity.

References

- Fustero, S., et al. (2009). Improved Regioselectivity in Pyrazole Formation through the Use of Fluorinated Alcohols as Solvents: Synthesis and Biological Activity of Fluorinated Tebufenpyrad Analogs. *The Journal of Organic Chemistry*. Available at: [\[Link\]](#)

- Fustero, S., et al. (2009). Improved Regioselectivity in Pyrazole Formation through the Use of Fluorinated Alcohols as Solvents: Synthesis and Biological Activity of Fluorinated Tebufenpyrad Analogs. Universitat de València. Available at: [\[Link\]](#)
- Panda, N., et al. (2022). Ce-catalyzed regioselective synthesis of pyrazoles from 1,2-diols via tandem oxidation and C–C/C–N bond formation. Organic & Biomolecular Chemistry. Available at: [\[Link\]](#)
- Ghandi, M., et al. (2024). Multicomponent syntheses of pyrazoles via (3 + 2)-cyclocondensation and (3 + 2)-cycloaddition key steps. Beilstein Journal of Organic Chemistry. Available at: [\[Link\]](#)
- Ghandi, M., et al. (2024). Multicomponent syntheses of pyrazoles via (3 + 2)-cyclocondensation and (3 + 2)-cycloaddition key steps. National Institutes of Health. Available at: [\[Link\]](#)
- Moody, C. J., et al. (2012). Synthesis of pyrazole containing α -amino acids via a highly regioselective condensation/aza-Michael reaction of β -aryl α,β -unsaturated ketones. RSC Publishing. Available at: [\[Link\]](#)
- Gulevskaya, A. V., et al. (2012). Cu(I)-catalyzed regioselective synthesis of pyrazolo[5,1-c]-1,2,4-triazoles. PubMed. Available at: [\[Link\]](#)
- Panda, N., et al. (2022). Ce-catalyzed regioselective synthesis of pyrazoles from 1,2-diols via tandem oxidation and C–C/C–N bond formation. Organic & Biomolecular Chemistry. Available at: [\[Link\]](#)
- Pons, J., et al. (2011). Preparation, separation and characterisation of two pyrazolic regioisomers of high purity. UAB Divulga. Available at: [\[Link\]](#)
- Organic Chemistry Portal. (n.d.). Pyrazole synthesis. Organic Chemistry Portal. Available at: [\[Link\]](#)
- Kim, S., et al. (2024). Regioselective Pyrazole Synthesis via Base-Mediated [3+2] Cycloaddition of 2-Alkynyl-1,3-Dithianes and Sydnone. The Journal of Organic Chemistry. Available at: [\[Link\]](#)

- Blackmond, D. G., et al. (2022). Discovery of unexpectedly complex reaction pathways for the Knorr pyrazole synthesis via transient flow. RSC Publishing. Available at: [\[Link\]](#)
- Ferreira, I. C. F. R., et al. (2019). Revisiting the Structure and Chemistry of 3(5)-Substituted Pyrazoles. National Institutes of Health. Available at: [\[Link\]](#)
- ResearchGate. (n.d.). Knorr Pyrazole Synthesis. ResearchGate. Available at: [\[Link\]](#)
- G. L. Starova, et al. (2024). Switching N-Alkylation Regioselectivity of Trifluoromethylated Pyrazoles Guided by Functional Group Tuning. MDPI. Available at: [\[Link\]](#)
- ResearchGate. (n.d.). Regioselective synthesis and computational calculation studies of some new pyrazolyl-pyridine and bipyridine derivatives. ResearchGate. Available at: [\[Link\]](#)
- J&K Scientific LLC. (2025). Knorr Pyrazole Synthesis. J&K Scientific LLC. Available at: [\[Link\]](#)
- El-Sawy, E. R., et al. (2021). Enantioselective Separation of Chiral N1-Substituted-1H-pyrazoles: Greenness Profile Assessment and Chiral Recognition Analysis. National Institutes of Health. Available at: [\[Link\]](#)
- Gomaa, A. M., et al. (2022). Substituted Pyrazoles and Their Heteroannulated Analogs—Recent Syntheses and Biological Activities. MDPI. Available at: [\[Link\]](#)
- Name-Reaction.com. (n.d.). Knorr pyrazole synthesis. Name-Reaction.com. Available at: [\[Link\]](#)
- Khan, I., et al. (2023). From 2011 to 2022: The development of pyrazole derivatives through the α,β -unsaturated carbonyl compounds. Semantic Scholar. Available at: [\[Link\]](#)
- Iovine, V., et al. (2022). Regioselective Synthesis, Structural Characterization, and Antiproliferative Activity of Novel Tetra-Substituted Phenylaminopyrazole Derivatives. PubMed Central. Available at: [\[Link\]](#)
- Katritzky, A. R., et al. (2001). Regioselective Synthesis of Polysubstituted Pyrazoles and Isoxazoles. The Journal of Organic Chemistry. Available at: [\[Link\]](#)
- Chem Help ASAP. (n.d.). Knorr Pyrazole Synthesis. Chem Help ASAP. Available at: [\[Link\]](#)

- Elguero, J., et al. (2025). The reaction between hydrazines and β -dicarbonyl compounds: Proposal for a mechanism. Canadian Journal of Chemistry. Available at: [\[Link\]](#)
- UAB Barcelona. (2011). Preparation, separation and characterization of two pyrazolic regioisomers of high purity. UAB Barcelona. Available at: [\[Link\]](#)
- Sharma, A., et al. (2025). Sustainable Routes and Mechanistic Study in Pyrazole Synthesis Using Deep Eutectic Solvents (DESS). Thieme. Available at: [\[Link\]](#)
- Sithambaram, K., et al. (2022). Synthesis of pyrazole derivatives and their spectroscopic properties investigated using both experimental and theoretical approaches. New Journal of Chemistry. Available at: [\[Link\]](#)
- Al-Amiery, A. A., et al. (2023). Green Synthesis and Biological Evaluation of Pyrazole Derivatives with Computational Chemistry Support. University of Baghdad College of Science. Available at: [\[Link\]](#)
- Kumar, V., et al. (2024). Recent advances in the multicomponent synthesis of pyrazoles. Organic & Biomolecular Chemistry. Available at: [\[Link\]](#)
- ResearchGate. (n.d.). Synthetic pathway for solvent-free preparations of pyrazole derivatives. ResearchGate. Available at: [\[Link\]](#)
- Khairulah, A.-E., et al. (2024). Synthesis, Anticancer Activity, and Computational Studies of New Pyrazole Derivatives. ResearchGate. Available at: [\[Link\]](#)

Need Custom Synthesis?

BenchChem offers custom synthesis for rare earth carbides and specific isotopic labeling.

Email: info@benchchem.com or [Request Quote Online](#).

Sources

- [1. benchchem.com \[benchchem.com\]](#)
- [2. benchchem.com \[benchchem.com\]](#)
- [3. benchchem.com \[benchchem.com\]](#)

- 4. Discovery of unexpectedly complex reaction pathways for the Knorr pyrazole synthesis via transient flow - Reaction Chemistry & Engineering (RSC Publishing) [DOI:10.1039/D2RE00271J](https://doi.org/10.1039/D2RE00271J) [pubs.rsc.org]
- 5. name-reaction.com [name-reaction.com]
- 6. ri.conicet.gov.ar [ri.conicet.gov.ar]
- 7. pubs.acs.org [pubs.acs.org]
- 8. BJOC - Multicomponent syntheses of pyrazoles via (3 + 2)-cyclocondensation and (3 + 2)-cycloaddition key steps [beilstein-journals.org]
- 9. Multicomponent syntheses of pyrazoles via (3 + 2)-cyclocondensation and (3 + 2)-cycloaddition key steps - PMC [pubmed.ncbi.nlm.nih.gov]
- 10. Preparation, separation and characterization of two pyrazolic regioisomers of high purity - Divulga UAB - University research dissemination magazine [uab.cat]
- 11. benchchem.com [benchchem.com]
- 12. Preparation, separation and characterization of two pyrazolic regioisomers of high purity UAB Barcelona [uab.cat]
- 13. benchchem.com [benchchem.com]
- 14. Regioselective Synthesis, Structural Characterization, and Antiproliferative Activity of Novel Tetra-Substituted Phenylaminopyrazole Derivatives - PMC [pubmed.ncbi.nlm.nih.gov]
- 15. jk-sci.com [jk-sci.com]
- 16. Synthesis of pyrazole containing α -amino acids via a highly regioselective condensation/aza-Michael reaction of β -aryl α,β -unsaturated ketones - Organic & Biomolecular Chemistry (RSC Publishing) [pubs.rsc.org]
- 17. Recent advances in the multicomponent synthesis of pyrazoles - Organic & Biomolecular Chemistry (RSC Publishing) [pubs.rsc.org]
- 18. pubs.acs.org [pubs.acs.org]
- 19. benchchem.com [benchchem.com]
- To cite this document: BenchChem. [Technical Support Center: Improving Regioselectivity in Pyrazole Synthesis]. BenchChem, [2026]. [Online PDF]. Available at: [<https://www.benchchem.com/product/b1592806/docs#technical-support-center-improving-regioselectivity-in-pyrazole-synthesis>]

Disclaimer & Data Validity:

The information provided in this document is for Research Use Only (RUO) and is strictly not intended for diagnostic or therapeutic procedures. While BenchChem strives to provide accurate protocols, we make no warranties, express or implied, regarding the fitness of this product for every specific experimental setup.

Technical Support: The protocols provided are for reference purposes. Unsure if this reagent suits your experiment?

Need Industrial/Bulk Grade? [Request Custom Synthesis Quote](#)

BenchChem

Our mission is to be the trusted global source of essential and advanced chemicals, empowering scientists and researchers to drive progress in science and industry.

Contact

Address: 3281 E Guasti Rd
Ontario, CA 91761, United States
Phone: (601) 213-4426
Email: info@benchchem.com

[Contact our Ph.D. Support Team for a compatibility check](#)