

Application Notes and Protocols: Phenanthrene Compounds in Materials Science

Author: BenchChem Technical Support Team. **Date:** May 2026

Compound of Interest

Compound Name: 2,3,6,7-TetraMethoxy-9-phenanthreneMethanol

CAS No.: 30062-15-8

Cat. No.: B031438

[Get Quote](#)

Introduction: The Phenanthrene Scaffold – A Convergence of Rigidity and Photophysical Excellence

Phenanthrene, a polycyclic aromatic hydrocarbon (PAH) comprising three fused benzene rings, represents a cornerstone in the design of advanced functional materials.[1] Its unique angular arrangement of rings imparts a rigid, planar, and highly conjugated π -electron system. This structure is not merely an isomeric curiosity of anthracene but a source of distinct and advantageous properties. Phenanthrene exhibits higher resonance energy and, consequently, greater thermodynamic and photochemical stability compared to its linear counterpart, anthracene.[2][3] Key characteristics such as high fluorescence quantum yields, excellent thermal stability, and strong intermolecular π - π stacking interactions make phenanthrene and its derivatives exceptionally versatile building blocks in materials science.[4]

This guide provides an in-depth exploration of the application of phenanthrene-based compounds in key areas of materials science. We will move beyond a simple survey of

applications to dissect the causal relationships behind their performance, offering detailed, field-proven protocols for their synthesis and device integration. For researchers, scientists, and drug development professionals, this document serves as a practical manual for harnessing the potential of the phenanthrene scaffold.

Section 1: Organic Light-Emitting Diodes (OLEDs): The Quest for Efficient and Stable Blue Emitters

Scientific Rationale: The development of stable, efficient, and pure-blue emitting materials remains a critical challenge in OLED technology. Phenanthrene derivatives have emerged as premier candidates to address this gap.^[4] Their large π -conjugated system results in a wide energy bandgap, which is conducive to blue emission. Furthermore, their rigid structure minimizes non-radiative decay pathways, leading to high photoluminescence quantum efficiencies.^[4] Functionalization of the phenanthrene core allows for precise tuning of the emission wavelength, charge transport properties, and thermal stability, making these compounds suitable as emitters, hosts, and charge-transporting materials in OLED devices.^[5] ^[6] Derivatives incorporating groups like indenopyrazine or dicyanopyrazine have demonstrated high efficiencies and color purity in the blue and even long-wavelength regions.^[7]^[8]

Protocol 1.1: Synthesis of a Cyanophenanthrene Derivative via Oxidative Photocyclization

This protocol describes a classic and effective method for creating a phenanthrene core from a stilbene precursor, a common strategy for producing materials for optoelectronics.^[9] The introduction of a cyano group can enhance electron affinity, which is beneficial for electron-injection layers.^[9]

Causality: The photocyclization of stilbene derivatives is a powerful method for forming the rigid phenanthrene ring system. The reaction proceeds via a photoinduced 6π -electrocyclization to form a dihydrophenanthrene intermediate, which is then oxidized (often by air in the presence of iodine as a catalyst) to the aromatic phenanthrene product. This method's reliability and tolerance for various functional groups make it a go-to strategy.

Materials:

- Substituted stilbene precursor (e.g., α -phenyl-4-methoxy-cinnamionitrile)

- Solvent (e.g., cyclohexane or toluene, spectroscopy grade)
- Iodine (catalytic amount)
- High-pressure mercury vapor lamp (or similar UV source)
- Quartz reaction vessel
- Magnetic stirrer and stir bar
- Rotary evaporator
- Silica gel for column chromatography
- Eluent (e.g., hexane/ethyl acetate mixture)

Procedure:

- **Solution Preparation:** Dissolve the stilbene precursor (1.0 g) in 500 mL of the chosen solvent in the quartz reaction vessel. The concentration should be low (around 0.01 M) to minimize intermolecular side reactions.
- **Deoxygenation:** Bubble argon or nitrogen gas through the solution for 30 minutes to remove dissolved oxygen, which can quench the excited state and interfere with the reaction.
- **Catalyst Addition:** Add a catalytic amount of iodine (approx. 5-10 mg). Iodine acts as an oxidizing agent for the dihydrophenanthrene intermediate.
- **Photoreaction:** Place the reaction vessel in proximity to the UV lamp and begin vigorous stirring. Irradiate the solution for 12-24 hours. Monitor the reaction progress using thin-layer chromatography (TLC). The formation of the phenanthrene product will be indicated by a new, more fluorescent spot.
- **Work-up:** After the reaction is complete, transfer the solution to a round-bottom flask. Add a saturated aqueous solution of sodium thiosulfate to quench any remaining iodine. Extract the organic layer, wash with brine, and dry over anhydrous magnesium sulfate.

- Purification: Remove the solvent using a rotary evaporator. Purify the crude product by column chromatography on silica gel to isolate the desired phenanthrene derivative.
- Characterization: Confirm the structure and purity of the final product using ^1H NMR, ^{13}C NMR, and mass spectrometry.

Protocol 1.2: Fabrication of a Solution-Processed OLED Device

This protocol outlines the fabrication of a standard multilayer OLED using spin-coating for the organic layers, a common technique in research laboratories.[\[10\]](#)[\[11\]](#)

Causality: The device architecture is designed to facilitate efficient charge injection, transport, and recombination within the emissive layer (EML). A hole transport layer (HTL) like PEDOT:PSS is used to smooth the indium tin oxide (ITO) anode surface and lower the energy barrier for hole injection. The phenanthrene-based emitter is spin-coated from a solution. Finally, a low work function metal cathode is thermally evaporated to ensure efficient electron injection. Each step is critical for achieving a high-performance device.[\[12\]](#)

Materials & Equipment:

- Pre-patterned ITO-coated glass substrates
- Hole Transport Layer (HTL): Poly(3,4-ethylenedioxythiophene) polystyrene sulfonate (PEDOT:PSS) aqueous dispersion
- Emissive Layer (EML): Synthesized phenanthrene derivative dissolved in a suitable solvent (e.g., toluene)
- Cleaning supplies: Hellmanex III detergent, deionized water, isopropyl alcohol, ultrasonic bath, nitrogen gun
- Spin coater (located in a nitrogen-filled glovebox)
- Hotplate (located in a glovebox)
- Thermal evaporator (located in a glovebox) with a cathode deposition mask

- Cathode material: Calcium (Ca) followed by Aluminum (Al)
- Encapsulation materials: UV-curable epoxy, glass coverslips

Procedure:

- Substrate Cleaning (Critical Step):
 - Immerse ITO substrates in a cleaning beaker with Hellmanex solution and sonicate for 15 minutes.
 - Rinse thoroughly with deionized water, then sonicate in fresh deionized water for 15 minutes.
 - Sonicate in isopropyl alcohol for 15 minutes.
 - Dry the substrates with a nitrogen gun and immediately transfer them into the glovebox.
- Hole Transport Layer (HTL) Deposition:
 - Place a cleaned substrate on the spin coater chuck.
 - Dispense ~30 μ L of filtered PEDOT:PSS solution onto the center of the substrate.
 - Spin coat at 4000 rpm for 40 seconds to achieve a film thickness of ~30-40 nm.[\[10\]](#)
 - Transfer the substrate to a hotplate and anneal at 120°C for 15 minutes to remove residual water.
- Emissive Layer (EML) Deposition:
 - Prepare a solution of the phenanthrene derivative (e.g., 10 mg/mL in toluene).
 - Allow the substrate to cool to room temperature.
 - Dispense ~30 μ L of the EML solution and spin coat at 2000 rpm for 40 seconds.
 - Anneal at 80°C for 20 minutes to remove the solvent.

- Cathode Deposition:
 - Transfer the substrate to the thermal evaporator.
 - Place a cathode deposition mask over the substrate, aligning it with the ITO pattern.
 - Evacuate the chamber to a high vacuum ($< 5 \times 10^{-6}$ Torr).
 - Sequentially evaporate Calcium (20 nm) and then Aluminum (100 nm) to form the cathode. The Al layer protects the reactive Ca from oxidation.
- Encapsulation:
 - Immediately after cathode deposition, apply a bead of UV-curable epoxy around the active area of the device.
 - Carefully place a glass coverslip over the epoxy and cure under a UV lamp. This step is crucial to prevent degradation from atmospheric oxygen and moisture.

Visualization & Data

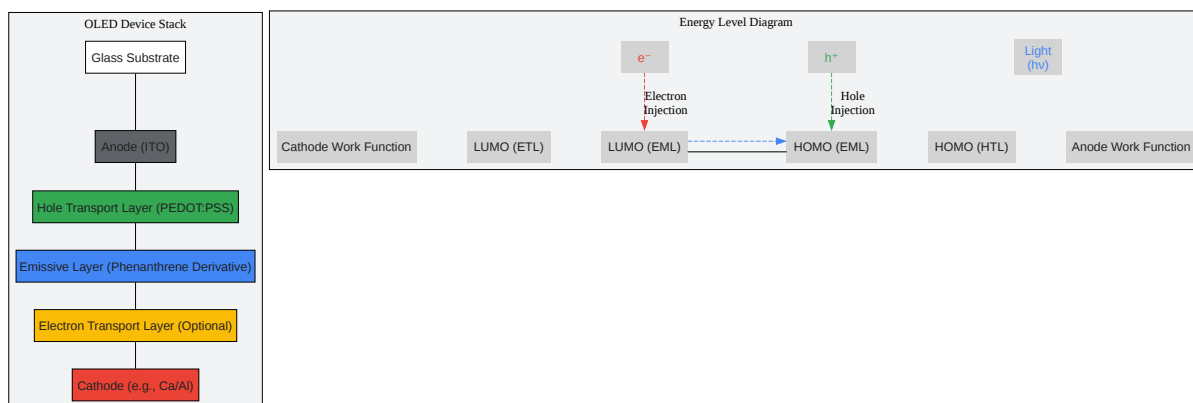

[Click to download full resolution via product page](#)

Caption: Structure and simplified energy diagram of a phenanthrene-based OLED.

Table 1: Performance of Selected Phenanthrene-Based OLEDs

Emitting Material Class	Max. Efficiency (cd/A)	Power Efficiency (lm/W)	CIE Coordinates (x, y)	Emission Color	Reference
Indenopyrazine Derivative (PA-EIP)	1.35	0.69	(0.17, 0.15)	Blue	[8]
Dicyanopyrazino Phenanthrene	47.6	14.8% (EQE)	(0.44, 0.54)	Yellow	[7]

| Dicyanopyrazino Phenanthrene | 12.8 | 10.1% (EQE) | (0.60, 0.40) | Red |[7] |

Section 2: Organic Field-Effect Transistors (OFETs): Engineering Environmentally Stable Semiconductors

Scientific Rationale: While acenes like pentacene have shown very high charge carrier mobilities, their poor stability in air and under illumination is a major drawback for practical applications.[2][3] Phenanthrene, with its higher resonance energy, offers a more robust and environmentally stable alternative.[2] Phenanthrene-based oligomers and polymers have been successfully used as both p-channel and n-channel semiconductors in OFETs.[2][13] Functionalization is key to performance; for example, attaching bithiophene units can improve mobility, while incorporating strong electron-withdrawing groups like imides and dicyanomethylene can create high-performance n-type polymers by lowering the LUMO energy level.[3][14][15]

Protocol 2.1: Fabrication of a Solution-Processable, Top-Contact/Bottom-Gate OFET

This protocol describes the fabrication of a common OFET architecture using a phenanthrene-based semiconductor deposited by spin-coating.[13][16]

Causality: The bottom-gate, top-contact architecture is chosen for its simplicity and the ability to pattern the gate and dielectric before depositing the sensitive organic semiconductor. A heavily doped silicon wafer serves as a common gate with a thermally grown silicon dioxide layer as the dielectric. Surface treatment of the dielectric is critical to promote favorable molecular packing of the phenanthrene semiconductor, which directly impacts charge carrier mobility. Gold is used for the source and drain electrodes due to its high work function and inertness.

Materials & Equipment:

- Substrate: Heavily n-doped Si wafer with a 300 nm thermally grown SiO₂ layer
- Surface treatment agent: Octadecyltrichlorosilane (OTS) solution in toluene
- Semiconductor: Phenanthrene-conjugated N-heteroacene or similar derivative dissolved in chloroform (e.g., 5 mg/mL)[16]
- Cleaning solvents: Acetone, isopropyl alcohol
- Spin coater (in glovebox)
- Thermal evaporator (in glovebox) with a source-drain electrode mask
- Substrate holder for annealing
- Semiconductor parameter analyzer for characterization

Procedure:

- Substrate Cleaning:
 - Cut the Si/SiO₂ wafer to the desired size (e.g., 1.5 cm x 1.5 cm).
 - Sonicate the substrates sequentially in acetone and isopropyl alcohol for 15 minutes each.
 - Dry thoroughly with a nitrogen gun.
 - Perform an O₂ plasma or UV-Ozone treatment for 10 minutes to create a hydrophilic surface with -OH groups for silanization.

- Dielectric Surface Treatment:
 - Immediately immerse the cleaned substrates in a 10 mM solution of OTS in anhydrous toluene for 20 minutes to form a self-assembled monolayer (SAM).
 - Rinse the substrates with fresh toluene to remove excess OTS.
 - Anneal the substrates at 120°C for 30 minutes to complete the SAM formation. This creates a hydrophobic surface that encourages ordered film growth.
- Semiconductor Film Deposition:
 - Transfer the surface-treated substrates into a nitrogen glovebox.
 - Deposit the phenanthrene semiconductor solution onto the substrate via spin-coating (e.g., at 2000 rpm for 60 seconds).[13]
 - Anneal the film at a temperature optimized for the specific material (e.g., 100-150°C) to improve crystallinity and film morphology.[2]
- Source-Drain Electrode Deposition:
 - Place the substrate with the organic film into a thermal evaporator.
 - Affix a shadow mask with the desired channel length and width for the source and drain electrodes.
 - Evacuate the chamber to high vacuum ($< 5 \times 10^{-6}$ Torr).
 - Thermally evaporate Gold (Au) to a thickness of 50 nm.
- Device Characterization:
 - Transfer the completed OFET device to a probe station connected to a semiconductor parameter analyzer.
 - Measure the transfer and output characteristics to extract key performance metrics like charge carrier mobility (μ), on/off current ratio, and threshold voltage (V_{th}).

Visualization & Data

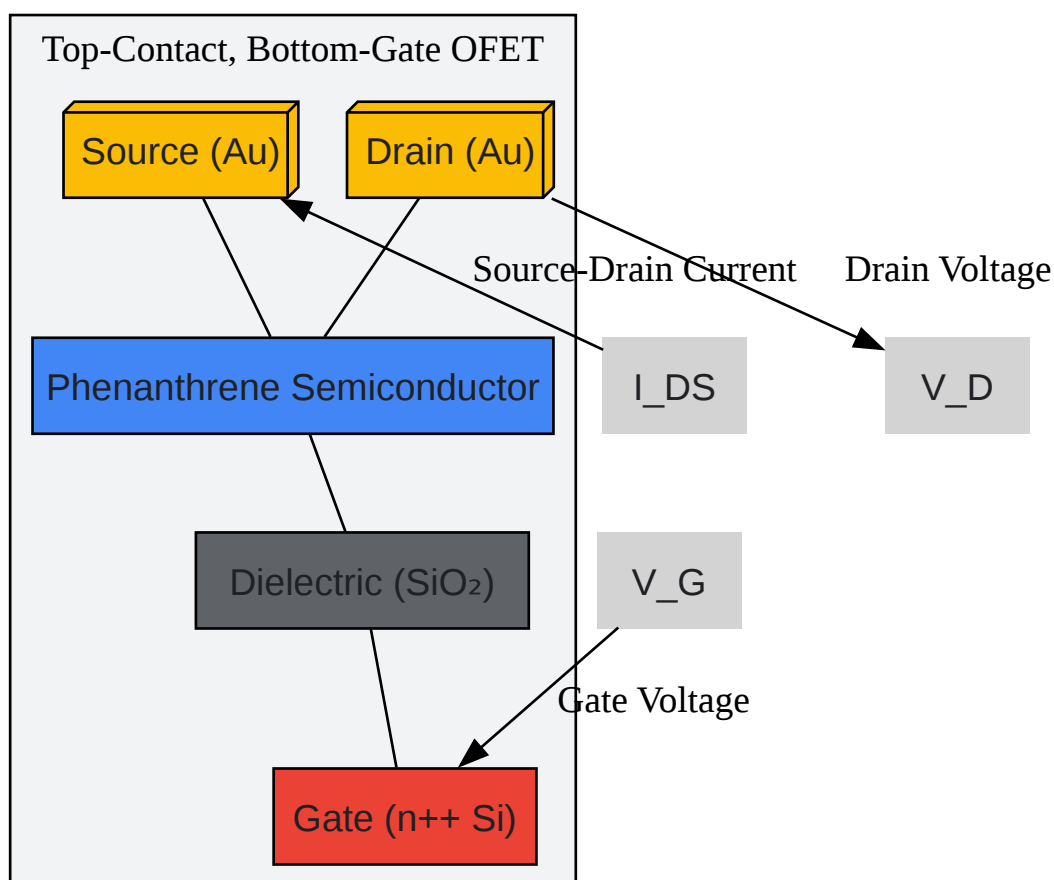

[Click to download full resolution via product page](#)

Caption: Schematic of a top-contact, bottom-gate Organic Field-Effect Transistor.

Table 2: Performance of Selected Phenanthrene-Based OFETs

Semiconductor Type	Mobility (μ) (cm ² /Vs)	On/Off Ratio	Channel Type	Reference
Phenanthrene Conjugated Oligomer (PhT2)	0.12	3×10^5	p-channel	[2]
Phenanthrene Conjugated N-heteroacene	4.27×10^{-3}	-	n-channel	[16]
Phenanthrene Imide-Based Polymer	~0.01 - 0.1	$> 10^5$	n-channel	[15]

| Trimer of Phenanthrene | 0.11 | - | p-channel [[3] |

Section 3: Fluorescent Sensors: Leveraging Photophysical Properties for Ion Detection

Scientific Rationale: The inherent fluorescence of the phenanthrene core makes it an excellent scaffold for chemical sensors.[17] By attaching specific recognition moieties (e.g., chelating groups), the photophysical properties of the molecule can be modulated upon binding to a target analyte. Common sensing mechanisms include Chelation-Enhanced Fluorescence (CHEF), where binding restricts molecular vibrations and enhances emission, and Photoinduced Electron Transfer (PET), where binding inhibits a quenching pathway, leading to a "turn-on" response.[17][18] Phenanthrene-imidazole conjugates, for example, have been designed as highly selective and sensitive "turn-on" fluorescent probes for metal ions like Cu²⁺, Ag⁺, and F⁻. [19][20][21]

Protocol 3.1: Screening for Metal Ion Sensing via Fluorescence Titration

This protocol provides a general method for evaluating the response of a phenanthrene-based fluorescent probe to various metal ions.[17]

Causality: The experiment is designed to systematically measure the change in the probe's fluorescence emission as the concentration of a potential analyte (metal ion) is increased. This allows for the determination of selectivity (which ions cause a response), sensitivity (the magnitude of the response), binding affinity, and the limit of detection (LOD). Using a buffered solution ensures that pH changes do not interfere with the fluorescence measurements.

Materials:

- Phenanthrene-based fluorescent probe (e.g., 4-Phenanthrenamine or a phenanthrene-imidazole derivative)[17][19]
- Solvent for probe stock solution (e.g., acetonitrile or DMSO)
- Buffer solution (e.g., 50 mM HEPES, pH 7.4)[20]
- Stock solutions (10 mM) of various metal salts (e.g., chlorides or nitrates of Cu^{2+} , Ag^+ , Zn^{2+} , Fe^{3+} , Hg^{2+} , etc.)
- Fluorometer
- Quartz cuvettes (1 cm path length)
- Micropipettes

Procedure:

- Stock Solution Preparation:
 - Prepare a 1 mM stock solution of the phenanthrene probe in a suitable organic solvent.
 - Prepare 10 mM stock solutions of the various metal salts in deionized water or acetonitrile.
- Working Solution Preparation:
 - Prepare a working solution of the probe (e.g., 10 μM) in the chosen buffer system (e.g., DMSO- H_2O (1:9 v/v) with 50 mM HEPES).[20]
- Initial Screening for Selectivity:

- To separate cuvettes, add 2 mL of the 10 μM probe solution.
- Record the baseline fluorescence emission spectrum (determine the optimal excitation wavelength, λ_{ex} , first).
- To each cuvette, add a significant excess (e.g., 10 equivalents) of a different metal ion stock solution.
- Mix thoroughly and record the fluorescence spectrum again. Compare the changes in fluorescence intensity to identify which metal ions elicit a response.
- Fluorescence Titration (for responsive ions):
 - Place 2 mL of the 10 μM probe solution in a clean cuvette and record its initial fluorescence spectrum.
 - Incrementally add small aliquots (e.g., 1-5 μL) of the stock solution of the target metal ion.
 - After each addition, mix gently and record the new fluorescence spectrum.
 - Continue the additions until the fluorescence intensity reaches a plateau, indicating saturation of the binding sites.
- Data Analysis:
 - Plot the fluorescence intensity at the emission maximum (λ_{em}) against the concentration of the metal ion.
 - From this plot, you can determine the binding stoichiometry (using a Job's plot), the association constant (K_a), and calculate the limit of detection (LOD).[\[20\]](#)

Visualization & Data

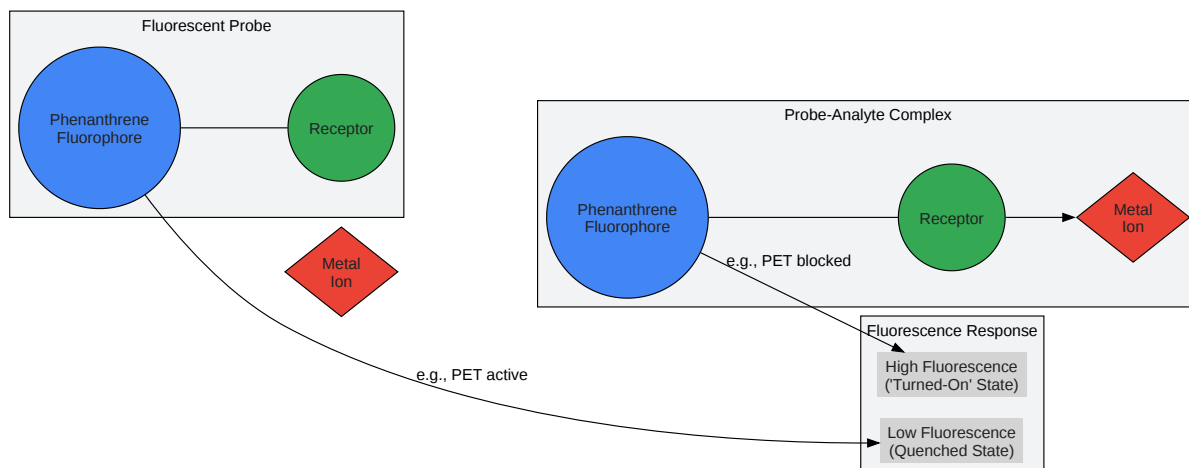

[Click to download full resolution via product page](#)

Caption: General mechanism for a "turn-on" fluorescent sensor upon analyte binding.

Table 3: Performance of a Phenanthrene-Imidazole Fluorescent Probe

Parameter	Value	Conditions	Reference
Target Analyte 1	Ag ⁺	DMSO-H ₂ O (1:9 v/v), pH 7.4	[20][21]
Limit of Detection (LOD)	1.8 nM	Fluorescence Titration	[20]
Association Constant (K _a)	8.24 x 10 ⁵ M ⁻¹	-	[20]
Target Analyte 2	F ⁻ (using the Ag ⁺ complex)	-	[20]

| Response Type | "Turn-on" fluorescence | - [[20] |

Section 4: Advanced Functional Polymers: From Adsorbents to Semiconductors

Scientific Rationale: Incorporating the rigid and aromatic phenanthrene unit into a polymer backbone can yield materials with remarkable properties. Through hyper-crosslinking reactions, phenanthrene can be used to create nanoporous polymers with very high surface areas.[22] The π -rich aromatic structure of these polymers makes them excellent adsorbents for CO₂ and organic dyes from wastewater, offering a sustainable approach to environmental remediation by upcycling a pollutant (phenanthrene) into a pollution-control material.[22] Furthermore, phenanthrene can be copolymerized with other units to create semiconducting polymers for electronic applications, as discussed in the OFET section.[14][15]

Protocol 4.1: Microwave-Assisted Synthesis of a Nanoporous Hypercrosslinked Phenanthrene Polymer

This protocol is adapted from a method to produce a highly effective adsorbent material (poly-PHEN-C) for CO₂ capture.[22]

Causality: The reaction uses a Friedel-Crafts alkylation approach where phenanthrene molecules are "knitted" together by short cross-linkers (derived from the chloroform solvent) in the presence of a Lewis acid catalyst (AlCl₃). The rigidity of the phenanthrene monomer

prevents the resulting network from collapsing upon solvent removal, thus creating permanent microporosity. Microwave assistance dramatically accelerates the reaction time compared to conventional heating, leading to a more energy-efficient synthesis.

Materials:

- Phenanthrene
- Anhydrous Aluminum Chloride (AlCl_3) - Handle with care in a dry environment
- Chloroform (CHCl_3) - Use in a fume hood
- Microwave reactor with a reflux condenser
- Methanol
- Hydrochloric acid (HCl), 5 M
- Soxhlet extraction apparatus
- Vacuum oven

Procedure:

- Reaction Setup: In a microwave reactor vessel, add phenanthrene (e.g., 1.0 g) and anhydrous AlCl_3 (e.g., 3.0 g).
- Solvent Addition: Add chloroform (20 mL), which acts as both the solvent and the cross-linking agent.
- Microwave Synthesis:
 - Seal the vessel and place it in the microwave reactor.
 - Set the reaction temperature to 60°C and the time to 30 minutes under constant stirring.
 - The reaction will produce a solid brown precipitate.
- Quenching and Washing:

- After cooling, carefully quench the reaction by slowly adding methanol (50 mL). This will deactivate the AlCl_3 catalyst.
- Filter the solid product and wash it repeatedly with methanol to remove unreacted monomers and catalyst residues.
- To ensure complete removal of the catalyst, wash the polymer with 5 M HCl, followed by copious amounts of deionized water until the filtrate is neutral.
- Purification:
 - Purify the polymer further by Soxhlet extraction with methanol for 24 hours to remove any remaining soluble impurities.
- Drying:
 - Dry the purified nanoporous polymer in a vacuum oven at 80°C overnight.
- Characterization:
 - Characterize the material's properties using techniques such as BET analysis (for surface area and pore volume), TGA (for thermal stability), and FTIR (to confirm the structure).

Visualization & Data

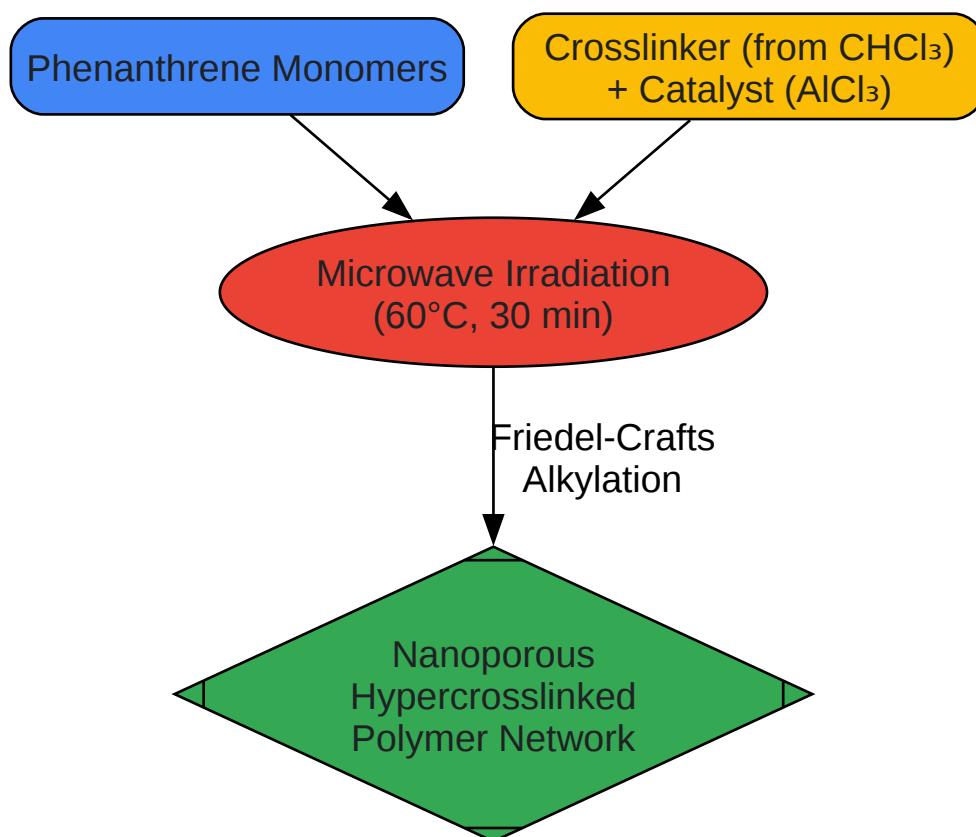

[Click to download full resolution via product page](#)

Caption: Workflow for microwave-assisted synthesis of a hypercrosslinked polymer.

Table 4: Properties of Nanoporous Hypercrosslinked Phenanthrene Polymer (poly-PHEN-C)

Property	Value	Method	Reference
BET Surface Area	1472 m ² /g	N ₂ adsorption at 77 K	[22]
Total Pore Volume	0.73 cm ³ /g	N ₂ adsorption at 77 K	[22]
CO ₂ Uptake Capacity	3.2 mmol/g	at 298 K, 1 bar	[22]
Crystal Violet Adsorption	161 mg/g	Batch process	[22]

| Alizarin Red S Adsorption | 120 mg/g | Batch process |[22] |

Conclusion and Future Outlook

The phenanthrene framework has unequivocally demonstrated its value as a high-performance building block in materials science. Its inherent stability, rigidity, and favorable photophysical properties have enabled significant advances in organic electronics, chemical sensing, and functional polymers. The applications detailed in this guide, from vibrant OLED displays and stable transistors to sensitive ion detectors and high-capacity sorbents, underscore the versatility of this remarkable molecule.

Future research will likely focus on developing more complex, multi-functionalized phenanthrene derivatives. The synthesis of novel phenanthrene-based polymers with tailored electronic properties will continue to drive progress in flexible and printed electronics. Furthermore, the integration of phenanthrene scaffolds into metal-organic frameworks (MOFs) and covalent organic frameworks (COFs) presents an exciting frontier for creating materials with unprecedented porosity and catalytic activity. As synthetic methodologies become more sophisticated, the full potential of phenanthrene in materials science is only beginning to be realized.

References

- A phenanthrene[9,10-d]imidazole-phenol-based fluorescent probe combining ESIPT and AIE for the “turn-on” detection of Cu²⁺ with green-emission and improved Stokes' shift, and its application. *New Journal of Chemistry* (RSC Publishing). Available at: [\[Link\]](#)
- Synthesis, Structures and Air-stable N-type Organic Field-effect Transistor (OFET) Properties of Functionalized-phenanthrene Conjugated Asymmetric N-heteroacenes. *PubMed*. Available at: [\[Link\]](#)
- Novel highly stable semiconductors based on phenanthrene for organic field-effect transistors. *Chemical Communications* (RSC Publishing). Available at: [\[Link\]](#)
- The Versatile Applications of Phenanthrene Derivatives in Electronics. NINGBO INNO PHARMCHEM CO.,LTD.. Available at: [\[Link\]](#)
- Highly Efficient Long-Wavelength Thermally Activated Delayed Fluorescence OLEDs Based on Dicyanopyrazino Phenanthrene Derivatives. *ACS Applied Materials & Interfaces*. Available at: [\[Link\]](#)

- Highly efficient blue emitting materials based on indenopyrazine derivatives for OLEDs [Invited]. Optica Publishing Group. Available at: [\[Link\]](#)
- Metal-Based Nanocomposite Materials for Efficient Photocatalytic Degradation of Phenanthrene from Aqueous Solutions. PMC - NIH. Available at: [\[Link\]](#)
- Organic semiconductors for organic field-effect transistors. PMC - NIH. Available at: [\[Link\]](#)
- Synthesis, Structures and Air-stable N-type Organic Field-effect Transistor (OFET) Properties of Functionalized-phenanthrene Conjugated Asymmetric N-heteroacenes. ResearchGate. Available at: [\[Link\]](#)
- Functionalized Phenanthrene Imide-Based Polymers for n-Type Organic Thin-Film Transistors. ResearchGate. Available at: [\[Link\]](#)
- (PDF) Phenanthrene-imidazole-based fluorescent sensor for selective detection of Ag⁺ and F⁻ ions: real sample application and live cell imaging. ResearchGate. Available at: [\[Link\]](#)
- Cascade Synthesis of Phenanthrenes under Photoirradiation. ACS Publications. Available at: [\[Link\]](#)
- Phenanthrene-imidazole-based fluorescent sensor for selective detection of Ag⁺ and F⁻ ions: real sample application and live cell imaging. Semantic Scholar. Available at: [\[Link\]](#)
- Photocatalytic degradation of phenanthrene in the presence of akaganeite nano-rods and the identification of degradation products. RSC Advances (RSC Publishing). Available at: [\[Link\]](#)
- Synthesis of Autofluorescent Phenanthrene Microparticles via Emulsification: A Useful Synthetic Mimic for Polycyclic Aromatic Hydrocarbon-Based Cosmic Dust. ACS Applied Materials & Interfaces. Available at: [\[Link\]](#)
- Phenanthrene Derived Nanoporous Hypercrosslinked Polymeric Adsorbent for CO₂ Capture from Flue Gas and Removal of Organic Dyes from Wastewater. ACS Applied Nano Materials. Available at: [\[Link\]](#)

- Functionalized Phenanthrene Imide-Based Polymers for n-Type Organic Thin-Film Transistors. PubMed. Available at: [\[Link\]](#)
- Degradation products of phenanthrene by different catalysts. ResearchGate. Available at: [\[Link\]](#)
- Method of preparation of Phenanthrene. Pharmacareerinsider. Available at: [\[Link\]](#)
- Synthesis of Phenanthrene/Pyrene Hybrid Microparticles: Useful Synthetic Mimics for Polycyclic Aromatic Hydrocarbon-Based Cosmic Dust. ACS Publications. Available at: [\[Link\]](#)
- A Three-Step Synthesis of 4H-Cyclopenta[def]phenanthrene from Pyrene. ResearchGate. Available at: [\[Link\]](#)
- Photocatalytic reactions of phenanthrene at TiO₂/water interfaces. ResearchGate. Available at: [\[Link\]](#)
- Functionalized Phenanthrene Imide-Based Polymers for n-Type Organic Thin-Film Transistors. ResearchGate. Available at: [\[Link\]](#)
- New phenanthrene-based organic semiconductor material for electronic devices. ResearchGate. Available at: [\[Link\]](#)
- Phenanthrene compounds for organic electronic devices. Google Patents.
- Synthesis of Phenanthrene/Pyrene Hybrid Microparticles: Useful Synthetic Mimics for Polycyclic Aromatic Hydrocarbon-Based Cosmic Dust. Journal of the American Chemical Society. Available at: [\[Link\]](#)
- Selected properties of phenanthrene and anthracene. ResearchGate. Available at: [\[Link\]](#)
- Synthesis and characterization of phenanthrene derivatives for optoelectronic applications. ResearchGate. Available at: [\[Link\]](#)
- PAH: Anthracene and phenanthrene. Saha et al.. Available at: [\[Link\]](#)
- The Method and Study of Detecting Phenanthrene in Seawater Based on a Carbon Nanotube–Chitosan Oligosaccharide Modified Electrode Immunosensor. PMC - NIH.

Available at: [\[Link\]](#)

- PHENANTHRENE Method of Preparations 1. Haworth synthesis. Gyan Sanchay. Available at: [\[Link\]](#)
- Synthesis and characterization of phenanthrene derivatives with anticancer property against human colon and epithelial cancer ce. ScienceDirect. Available at: [\[Link\]](#)
- The Role of Naphthalene and Anthracene Derivatives in Modern OLED Technology. NINGBO INNO PHARMCHEM CO.,LTD.. Available at: [\[Link\]](#)
- Manufacturing Process and Key Technologies of OLED. DisplayMan. Available at: [\[Link\]](#)
- Fabrication of Organic Light Emitting Diodes (OLEDs) using the Lamination method in a Vacuum-Free Environment. IEEE Xplore. Available at: [\[Link\]](#)
- Phenanthrene. ResearchGate. Available at: [\[Link\]](#)
- Preparation method of OLED (Organic Light Emitting Diode) device and.... Google Patents.

Need Custom Synthesis?

BenchChem offers custom synthesis for rare earth carbides and specific isotopic labeling.

Email: info@benchchem.com or [Request Quote Online](#).

Sources

- [1. researchgate.net \[researchgate.net\]](https://www.researchgate.net)
- [2. Novel highly stable semiconductors based on phenanthrene for organic field-effect transistors - Chemical Communications \(RSC Publishing\) \[pubs.rsc.org\]](https://pubs.rsc.org)
- [3. Organic semiconductors for organic field-effect transistors - PMC \[pmc.ncbi.nlm.nih.gov\]](https://pubmed.ncbi.nlm.nih.gov)
- [4. alternative-energy.alfa-chemistry.com \[alternative-energy.alfa-chemistry.com\]](https://www.alfa-chemistry.com)
- [5. nbinno.com \[nbinno.com\]](https://www.nbinno.com)
- [6. nbinno.com \[nbinno.com\]](https://www.nbinno.com)
- [7. pubs.acs.org \[pubs.acs.org\]](https://pubs.acs.org)

- [8. OPG \[opg.optica.org\]](#)
- [9. researchgate.net \[researchgate.net\]](#)
- [10. ossila.com \[ossila.com\]](#)
- [11. CN104253247A - Preparation method of OLED \(Organic Light Emitting Diode\) device and OLED device prepared by adopting preparation method - Google Patents \[patents.google.com\]](#)
- [12. displayman.com \[displayman.com\]](#)
- [13. researchgate.net \[researchgate.net\]](#)
- [14. researchgate.net \[researchgate.net\]](#)
- [15. Functionalized Phenanthrene Imide-Based Polymers for n-Type Organic Thin-Film Transistors - PubMed \[pubmed.ncbi.nlm.nih.gov\]](#)
- [16. Synthesis, Structures and Air-stable N-type Organic Field-effect Transistor \(OFET\) Properties of Functionalized-phenanthrene Conjugated Asymmetric N-heteroacenes - PubMed \[pubmed.ncbi.nlm.nih.gov\]](#)
- [17. pdf.benchchem.com \[pdf.benchchem.com\]](#)
- [18. pdf.benchchem.com \[pdf.benchchem.com\]](#)
- [19. A phenanthrene\[9,10-d\]imidazole-phenol-based fluorescent probe combining ESIPT and AIE for the “turn-on” detection of Cu²⁺ with green-emission and improved Stokes’ shift, and its application - New Journal of Chemistry \(RSC Publishing\) \[pubs.rsc.org\]](#)
- [20. researchgate.net \[researchgate.net\]](#)
- [21. Phenanthrene-imidazole-based fluorescent sensor for selective detection of Ag⁺ and F⁻ ions: real sample application and live cell imaging | Semantic Scholar \[semanticscholar.org\]](#)
- [22. pubs.acs.org \[pubs.acs.org\]](#)
- To cite this document: BenchChem. [Application Notes and Protocols: Phenanthrene Compounds in Materials Science]. BenchChem, [2026]. [Online PDF]. Available at: [https://www.benchchem.com/product/b031438/docs#application-notes-and-protocols-phenanthrene-compounds-in-materials-science]

Disclaimer & Data Validity:

The information provided in this document is for Research Use Only (RUO) and is strictly not intended for diagnostic or therapeutic procedures. While BenchChem strives to provide

accurate protocols, we make no warranties, express or implied, regarding the fitness of this product for every specific experimental setup.

Technical Support: The protocols provided are for reference purposes. Unsure if this reagent suits your experiment?

Need Industrial/Bulk Grade? [Request Custom Synthesis Quote](#)

BenchChem

Our mission is to be the trusted global source of essential and advanced chemicals, empowering scientists and researchers to drive progress in science and industry.

Contact

Address: 3281 E Guasti Rd

Ontario, CA 91761, United States

Phone: (601) 213-4426

Email: info@benchchem.com

[Contact our Ph.D. Support Team for a compatibility check](#)