

Application Note: Scalable Synthesis of 3-Chloro-5-isopropoxyaniline

Author: BenchChem Technical Support Team. **Date:** April 2026

Compound of Interest

Compound Name: 3-Chloro-5-isopropoxyaniline

CAS No.: 1312138-90-1

Cat. No.: B3097508

[Get Quote](#)

Executive Summary & Route Selection

The synthesis of **3-Chloro-5-isopropoxyaniline** presents a classic regioselectivity challenge: installing two different substituents (chloro and isopropoxy) in a meta relationship relative to an amine.

Route Analysis

We evaluated three potential synthetic pathways for kilogram-scale production:

- Route A (Phenol Alkylation): 3-Amino-5-chlorophenol

O-Alkylation.

- Verdict: Rejected. 3-Amino-5-chlorophenol is expensive and prone to oxidation/polymerization during storage.

- Route B (Nitration of m-Alkoxychlorobenzene): 1-Chloro-3-isopropoxybenzene

Nitration.

- Verdict: Rejected. Nitration is non-regioselective, yielding a mixture of ortho and para isomers relative to the alkoxy group, requiring difficult separation.
- Route C (Regioselective S_NAr on 3,5-Dichloronitrobenzene): 3,5-Dichloronitrobenzene

S_NAr

Reduction.

- Verdict: Selected. This route leverages the kinetic self-termination of nucleophilic aromatic substitution. The starting material (3,5-dichloronitrobenzene) is commercially available and electron-deficient. The introduction of the electron-donating isopropoxy group deactivates the ring toward a second substitution, ensuring high mono-selectivity.

Selected Process Flow

The optimized protocol consists of two chemical steps:

- Nucleophilic Aromatic Substitution (S_NAr): Reaction of 3,5-dichloronitrobenzene with sodium isopropoxide.
- Chemoselective Reduction: Hydrogenation of the nitro group to the aniline without hydrodechlorination.

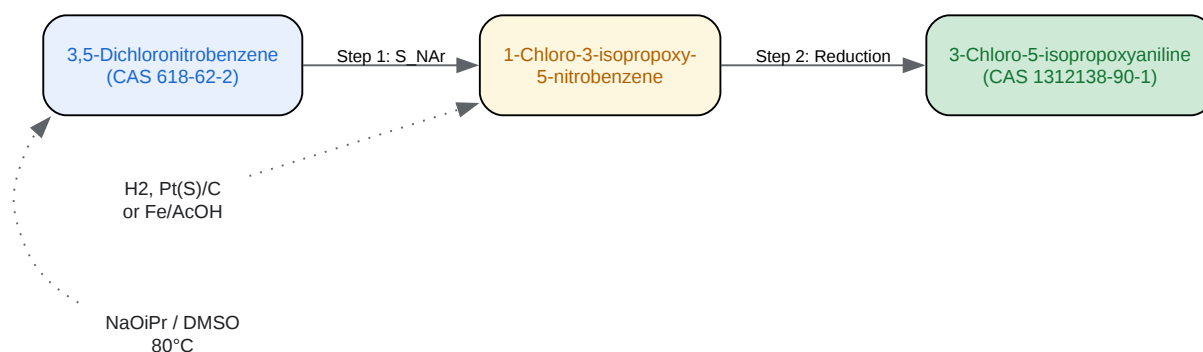

[Click to download full resolution via product page](#)

Figure 1: Strategic Route for **3-Chloro-5-isopropoxyaniline** Synthesis.

Step 1: Regioselective Etherification (S_NAr)

Objective: Convert 3,5-dichloronitrobenzene to 1-chloro-3-isopropoxy-5-nitrobenzene.

Process Logic & Mechanism

Although the nitro group is meta to the chlorides (and thus provides weak resonance activation compared to ortho/para), the cumulative inductive electron-withdrawing effect of the nitro group and the two chlorine atoms renders the ring sufficiently electrophilic for attack by strong nucleophiles like alkoxides [1].^[1]

Critical Control Point (Self-Validating System): The reaction relies on product deactivation. The starting material has three Electron Withdrawing Groups (EWGs). The product replaces one Cl (EWG) with an Isopropoxy group (Electron Donating Group - EDG). This significantly raises the electron density of the ring, making the product orders of magnitude less reactive than the starting material towards a second S_NAr event. This ensures that bis-isopropoxy impurity formation is kinetically suppressed [2].

Protocol (Scale: 1.0 kg Input)

Materials:

- 3,5-Dichloronitrobenzene (3,5-DCNB): 1.0 kg (5.21 mol)
- Sodium Isopropoxide (20% w/w in THF/Toluene) or prepared in situ: 1.2 eq (6.25 mol)
- Anhydrous DMSO (Dimethyl Sulfoxide): 5.0 L (5 vol)
- Toluene: 5.0 L (Workup)

Procedure:

- Setup: Charge a 20 L jacketed glass reactor with 3,5-DCNB (1.0 kg) and DMSO (5.0 L). Stir until fully dissolved.

- Note: DMSO is chosen for its high dielectric constant, which stabilizes the Meisenheimer complex transition state, accelerating the reaction significantly compared to alcoholic solvents.
- Reagent Preparation: In a separate vessel, prepare Sodium Isopropoxide (solid NaOiPr dissolved in minimal THF or prepared from NaH + IPA).
 - Safety: NaH releases hydrogen gas. Ensure adequate venting.
- Addition: Heat the reactor contents to 60°C. Add the Sodium Isopropoxide solution dropwise over 2 hours.
 - Exotherm Control: Maintain internal temperature between 60–70°C. Do not exceed 80°C to prevent thermal decomposition of the nitro compound.
- Reaction: Stir at 70°C for 4–6 hours.
 - IPC (In-Process Control): Monitor by HPLC. Target: <1.0% remaining 3,5-DCNB.
- Quench & Workup:
 - Cool to 20°C.
 - Slowly add Water (10 L) to the reactor (Exothermic!).
 - Extract with Toluene (2 x 5 L).
 - Wash combined organic layers with Brine (5 L) and Water (5 L) to remove residual DMSO.
- Concentration: Distill Toluene under reduced pressure to obtain the crude nitro intermediate as a yellow/orange oil or low-melting solid.
 - Yield Expectation: 85–92% (approx. 0.95–1.03 kg).

Key Impurities:

Impurity	Origin	Control Strategy
3,5-Diisopropoxynitrobenzene	Over-reaction (Bis-substitution)	Keep conversion <99% or lower temperature; exploit kinetic deactivation.

| 3,5-Dichlorophenol | Hydrolysis (Water in solvent) | Ensure anhydrous DMSO and reagents. |

Step 2: Chemoselective Reduction

Objective: Reduce the nitro group to an amine while preserving the aryl chloride.

Process Logic

Standard hydrogenation (Pd/C, H₂) poses a severe risk of hydrodechlorination (stripping the chlorine atom), yielding 3-isopropoxyaniline. To prevent this, we must use a catalyst system that is selective for nitro reduction or poison the catalyst to inhibit C-Cl bond insertion [3].

Recommended Method: Sulfided Platinum on Carbon (Pt(S)/C) Sulfided platinum catalysts are industrially standard for halonitrobenzene reductions. The sulfur acts as a poison, occupying the high-energy sites responsible for C-Cl activation while leaving the sites for -NO₂ reduction active.

Protocol (Scale: 1.0 kg Intermediate)

Materials:

- 1-Chloro-3-isopropoxy-5-nitrobenzene (Crude from Step 1): 1.0 kg
- Catalyst: 5% Pt(S)/C (Sulfided Platinum): 20 g (2 wt% loading)
- Solvent: Methanol or Ethyl Acetate: 10 L (10 vol)
- Hydrogen Gas: 5–10 bar

Procedure:

- Loading: Charge the hydrogenation autoclave with the nitro intermediate, Solvent (Methanol), and Pt(S)/C catalyst.
 - Safety: Load catalyst under inert atmosphere (Nitrogen) to prevent ignition of solvent vapors.
- Purging: Purge the vessel 3 times with Nitrogen (5 bar), then 3 times with Hydrogen (5 bar).
- Reaction: Pressurize to 5–10 bar H₂ and heat to 40°C. Stir vigorously (gas-liquid mass transfer is rate-limiting).
- Monitoring: Monitor hydrogen uptake. Reaction typically completes in 4–8 hours.
 - IPC: HPLC should show <0.5% Nitro intermediate and <0.5% De-chlorinated byproduct (3-isopropoxyaniline).
- Filtration: Vent H₂, purge with Nitrogen. Filter the catalyst through a spark-proof filter (e.g., Celite bed).
 - Catalyst Recovery: Keep catalyst wet (pyrophoric when dry).
- Isolation: Concentrate the filtrate. The product, **3-Chloro-5-isopropoxyaniline**, is an oil that may crystallize upon standing or conversion to the HCl salt.
 - Purification: If necessary, distill under high vacuum or crystallize as the Hydrochloride salt (add HCl in IPA/Ether).

Analytical Controls & Specifications

HPLC Method Parameters

- Column: C18 Reverse Phase (e.g., Agilent Zorbax SB-C18, 4.6 x 150 mm, 3.5 µm).
- Mobile Phase: A: 0.1% H₃PO₄ in Water; B: Acetonitrile.
- Gradient: 10% B to 90% B over 15 min.
- Detection: UV at 254 nm.

Specification Sheet (Target)

Parameter	Specification	Method
Appearance	Pale yellow to brown oil/solid	Visual
Purity	> 98.0% (Area %)	HPLC
3,5-Dichloroaniline	< 0.10%	HPLC (Carryover)
3-Isopropoxyaniline	< 0.50%	HPLC (De-chlorinated)
Water Content	< 0.5%	KF Titration

Scale-Up Challenges & Safety

Thermal Hazards (DSC Data)

- 3,5-Dichloronitrobenzene: Stable, but nitro compounds are energetic.
- S_NAr Reaction: Exothermic. The heat of reaction is estimated at -150 kJ/mol. In a 20 L reactor, adiabatic temperature rise could be >50°C if dosing is uncontrolled. Action: Use dosing pumps interlocked with reactor temperature sensors.

Solvent Recycling[6]

- DMSO: Difficult to recycle due to high boiling point. For multi-ton scale, consider replacing DMSO with NMP (N-Methyl-2-pyrrolidone) or using phase-transfer catalysis (PTC) in Toluene/Water, though reaction rates will be slower.

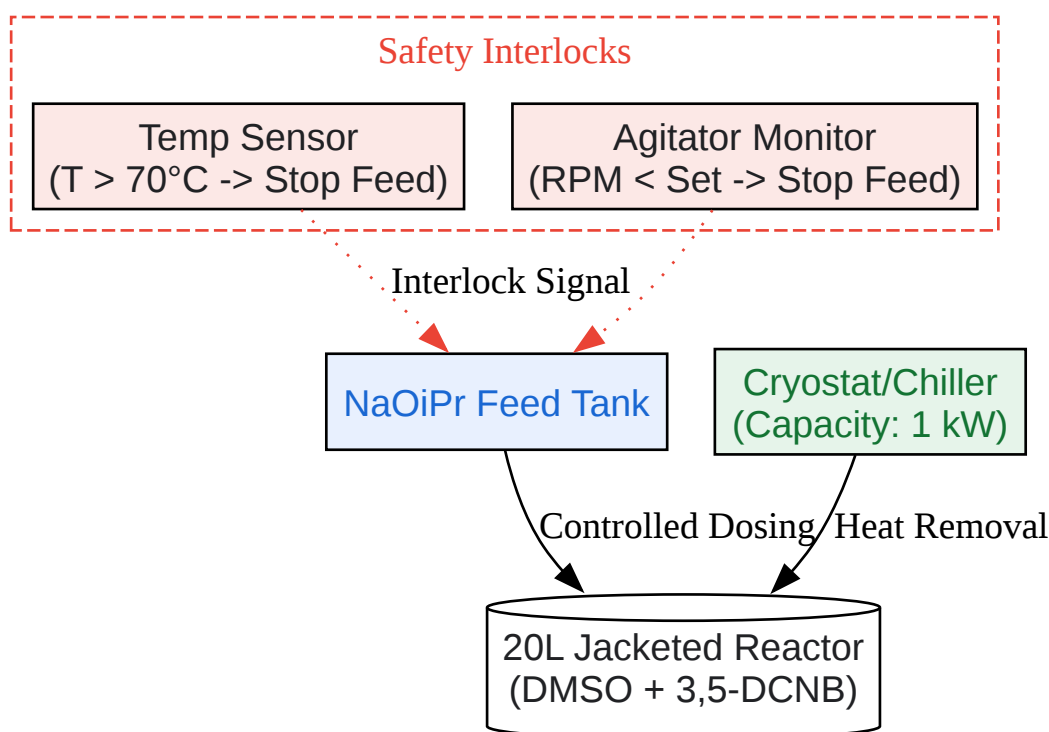

[Click to download full resolution via product page](#)

Figure 2: Reactor Safety Setup for Exothermic S_NAr Step.

References

- Bunnett, J. F., & Zahler, R. E. (1951). Nucleophilic Substitution Reactions in Aromatic Systems. *Chemical Reviews*, 49(2), 273–412. [Link](#)
- Gore, P. H. (1955). The effect of structure on the reactivity of the benzene ring. *Progress in Stereochemistry*, 1, 159. (Foundational text on substituent effects in S_NAr).
- Rylander, P. N. (1979). *Catalytic Hydrogenation in Organic Synthesis*. Academic Press. (Standard reference for Pt(S)/C selectivity).
- BenchChem. (2025).^{[2][3][4]} Synthesis of 3-Isopropoxyaniline from 3-Aminophenol: A Technical Guide. ⁵ (Analogous ether synthesis reference).
- ChemicalBook. (2025).^[6] 3,5-Dichloronitrobenzene Properties and Synthesis. ⁷

Need Custom Synthesis?

BenchChem offers custom synthesis for rare earth carbides and specific isotopic labeling.

Email: info@benchchem.com or [Request Quote Online](#).

Sources

- [1. chemistry.stackexchange.com](https://chemistry.stackexchange.com) [chemistry.stackexchange.com]
- [2. pdf.benchchem.com](https://pdf.benchchem.com) [pdf.benchchem.com]
- [3. pdf.benchchem.com](https://pdf.benchchem.com) [pdf.benchchem.com]
- [4. pdf.benchchem.com](https://pdf.benchchem.com) [pdf.benchchem.com]
- [5. 3-Isopropoxyaniline | 41406-00-2 | Benchchem](https://www.benchchem.com) [[benchchem.com](https://www.benchchem.com)]
- [6. The reaction of m-chloronitrobenzene with sodium methoxide is much slower..](#) [askfilo.com]
- [7. 3,5-Dichloronitrobenzene \(CAS 618-62-2\) - Chemical & Physical Properties by Cheméo](#) [cheméo.com]
- To cite this document: BenchChem. [Application Note: Scalable Synthesis of 3-Chloro-5-isopropoxyaniline]. BenchChem, [2026]. [Online PDF]. Available at: [<https://www.benchchem.com/product/b3097508/docs#application-note-scalable-synthesis-of-3-chloro-5-isopropoxyaniline>]

Disclaimer & Data Validity:

The information provided in this document is for Research Use Only (RUO) and is strictly not intended for diagnostic or therapeutic procedures. While BenchChem strives to provide accurate protocols, we make no warranties, express or implied, regarding the fitness of this product for every specific experimental setup.

Technical Support: The protocols provided are for reference purposes. Unsure if this reagent suits your experiment?

Need Industrial/Bulk Grade? [Request Custom Synthesis Quote](#)

BenchChem

Our mission is to be the trusted global source of essential and advanced chemicals, empowering scientists and researchers to drive progress in science and industry.

Contact

Address: 3281 E Guasti Rd

Ontario, CA 91761, United States

Phone: (601) 213-4426

Email: info@benchchem.com

[Contact our Ph.D. Support Team for a compatibility check](#)