

Resolving regioisomer formation in 5-phenylpyridine functionalization

Author: BenchChem Technical Support Team. **Date:** May 2026

Compound of Interest

Compound Name: 3,4-Diamino-5-phenylpyridine

CAS No.: 1214345-15-9

Cat. No.: B3090874

[Get Quote](#)

Welcome to the Heterocycle Functionalization Technical Support Center.

Ticket #: 5-PhPy-REGIO-001 Topic: Resolving Regioisomer Formation in 5-Phenylpyridine Functionalization Assigned Specialist: Senior Application Scientist, High-Throughput Experimentation Unit[1]

Executive Summary: The Scaffold Challenge

You are working with 3-phenylpyridine (often referred to as 5-phenylpyridine depending on substitution history).[1] This scaffold presents a unique "biaryl" challenge where two aromatic rings compete for functionalization, governed by distinct electronic and steric rules.[1]

- The Pyridine Ring: Electron-deficient.[2] Prone to nucleophilic attack (radical Minisci) at C2/C6 but resistant to electrophilic attack.[1]
- The Phenyl Ring: Electron-neutral/rich. Prone to electrophilic attack (EAS) or steric-controlled C-H activation (Ir-catalyzed).[1]

The Core Regio-Problem:

- Pyridine C2 vs. C6: Competition between the "inner" hindered position (C2) and the "outer" accessible position (C6).
- Phenyl Ring Selectivity: Distinguishing between ortho, meta, and para positions relative to the pyridine linkage.[\[1\]](#)

Module 1: Functionalizing the Pyridine Ring (Radical Pathways)

User Scenario: "I am trying to alkylate the pyridine ring using a Minisci reaction, but I am getting a mixture of C2 and C6 isomers, or exclusively the 'outer' C6 product."

Technical Diagnosis

In 3-phenylpyridine, the C2 position is sterically flanked by the phenyl ring and the nitrogen lone pair. The C6 position is sterically open. Radical additions (Minisci type) are highly sensitive to sterics.[\[1\]](#)

- Default Outcome: High selectivity for C6 (the "outer" position).[\[1\]](#)
- The Challenge: Forcing functionalization at C2 (the "inner" position).

Troubleshooting Protocol: Reversing Selectivity

Q: How do I shift selectivity toward the hindered C2 position?

A: You must employ "Polarity Reversal" or "Blocking" strategies.[\[1\]](#)

Strategy	Methodology	Mechanism
N-Oxide Activation	Oxidize pyridine to Pyridine-N-oxide before functionalization.	The N-oxide oxygen creates a dipole that can direct specific radical species or allow for subsequent rearrangement (e.g., Boekelheide reaction) to C2.
Radical Nucleophilicity	Switch from alkyl radicals (nucleophilic) to carbamoyl/acyl radicals.[1]	More nucleophilic radicals are more sensitive to the electron-deficient C2/C4/C6 positions. However, steric sensitivity remains high.[1]
Acid Modulation	Increase TFA concentration or switch to stronger Lewis Acids (BF ₃ [1]·OEt ₂).	Protonation/complexation of N lowers the LUMO of the pyridine, increasing overall reactivity, but often exacerbates C6 selectivity due to increased steric bulk at Nitrogen.

Standard Operating Procedure (SOP): C6-Selective Alkylation

Recommended for late-stage functionalization.[1]

- Substrate: 0.5 mmol 3-phenylpyridine.
- Solvent: 2.5 mL DCM:H₂O (biphasic) or TFA (homogenous).
- Radical Source: 2.0 equiv Zinc Sulfinat (e.g., DFMS for CF₂H).[1]
- Oxidant: 3.0 equiv TBHP (70% aq).[1]
- Temperature: 0°C to RT (Control exotherm to prevent polysubstitution).

Module 2: Functionalizing the Phenyl Ring (Steric Control)

User Scenario: "I want to borylate the phenyl ring to create a handle for Suzuki coupling, but I'm worried about hitting the pyridine ring."

Technical Diagnosis

Iridium-catalyzed C-H borylation is governed almost exclusively by sterics, not electronics.[1]

- Pyridine N: Coordinates to Ir, potentially poisoning the catalyst unless sterically protected.[1]
- Selectivity: The catalyst will avoid:
 - Ortho to the pyridine nitrogen (C2/C6).[1]
 - Ortho to the phenyl linkage (Phenyl C2'/C6').[1]
- Result: Functionalization occurs at the Phenyl Meta (C3'/C5') or Para (C4') positions.[1]

Decision Matrix: Ligand Selection

Q: Which ligand system should I use to avoid catalyst poisoning by the pyridine nitrogen?

A: Use electron-rich bipyridine ligands or bulky phenanthrolines.

Ligand	Selectivity Profile	Notes
dtbpy (4,4'-di-tert-butyl-2,2'-bipyridine)	Standard. Favors sterically accessible phenyl meta/para positions.[1]	Robust. The tert-butyl groups prevent the ligand from dissociating, maintaining the active Ir(III)/Ir(V) cycle.
TMP-Phen (3,4,7,8-tetramethyl-1,10-phenanthroline)	High Activity. Often pushes reaction to completion even with deactivated arenes.[1]	Useful if the phenyl ring has other electron-withdrawing groups.

Visual Guide: Steric Exclusion Zones

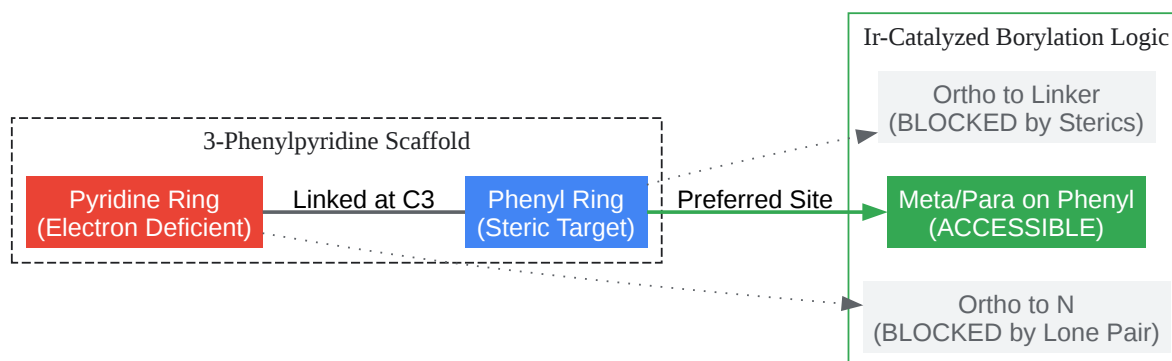

[Click to download full resolution via product page](#)

Caption: Steric exclusion map for Ir-catalyzed borylation. Green zones indicate accessible sites.[1]

Module 3: Directing Group (DG) Strategies

User Scenario: "I specifically need to functionalize the phenyl ring ORTHO to the pyridine linkage (C2')."

Technical Diagnosis

This is the most difficult regio-outcome. The pyridine nitrogen is too far (distal) to act as a directing group for the phenyl ring's ortho position (which is 4 atoms away).

- Standard Pd-Catalysis: Will likely fail or give mixtures.[1]
- Solution: You need a Transient Directing Group (TDG) or a Template.[1]

Experimental Workflow: The Template Approach

To hit the "inner" ortho position of the phenyl ring, you must use a template that coordinates to the pyridine nitrogen and "reaches" over to activate the C-H bond.

- Catalyst: Pd(OAc)₂.

- Ligand: Yu-Wasa type ligands (bifunctional ligands containing a carboxylic acid and a coordinating pyridine/quinoline motif).[1]
- Mechanism: The ligand coordinates Pd, while the carboxylic acid moiety acts as a proton shuttle (CMD mechanism) specifically positioned to deprotonate the C-H bond ortho to the linkage.

FAQ: Rapid Troubleshooting

Q1: My Minisci reaction turned into black tar. What happened? A: You likely added the oxidant (TBHP/Persulfate) too quickly or at too high a temperature. Pyridines are prone to polymerization under radical conditions.[1]

- Fix: Add oxidant via syringe pump over 2 hours.[1] Lower temperature to 0°C.

Q2: I can't separate the C2 and C6 isomers after alkylation. A: These regioisomers often have very similar R_f values.

- Fix: Do not use standard Silica.[1] Switch to C18 Reverse Phase chromatography. The difference in dipole moment between the "linear" (C5-C2 substituted) and "bent" (C5-C6 substituted) isomers is usually resolved better on C18.

Q3: Can I use electrophilic aromatic substitution (Nitration/Bromination)? A: Only if you want to hit the Phenyl ring.[1] The pyridine ring is too deactivated.

- Outcome: Nitration will occur on the Phenyl ring at the ortho or para position (relative to the pyridine, which acts as an electron-withdrawing group).

References

- Steric Control in Ir-Catalyzed Borylation: Partridge, B. M., & Hartwig, J. F. (2013).[1][3] Sterically Controlled Iodination of Arenes via Iridium-Catalyzed C-H Borylation.[3] Organic Letters.
- Minisci Reaction Regioselectivity: Proctor, R. S. J., & Phipps, R. J. (2019).[1] Recent Advances in Minisci-Type Reactions. Angewandte Chemie International Edition. [1]

- Distal C-H Activation (Template Approach): Leow, D., Li, G., Mei, T.-S., & Yu, J.-Q. (2012).[1] Activation of Remote meta-C–H Bonds Assisted by an End-on Template. Nature.[1] [1]
- Mechanism of Pyridine C-H Functionalization: Hickman, A. J., & Sanford, M. S. (2012).[1] High-Valent Organometallic Copper and Palladium in Catalysis. Nature.[1] [1]

Need Custom Synthesis?

BenchChem offers custom synthesis for rare earth carbides and specific isotopic labeling.

Email: info@benchchem.com or [Request Quote Online](#).

Sources

- [1. pubs.acs.org](https://pubs.acs.org) [pubs.acs.org]
- [2. pubs.acs.org](https://pubs.acs.org) [pubs.acs.org]
- [3. Sterically Controlled Iodination of Arenes via Iridium-Catalyzed C-H Borylation](https://organic-chemistry.org) [organic-chemistry.org]
- To cite this document: BenchChem. [Resolving regioisomer formation in 5-phenylpyridine functionalization]. BenchChem, [2026]. [Online PDF]. Available at: [<https://www.benchchem.com/product/b3090874/docs#resolving-regioisomer-formation-in-5-phenylpyridine-functionalization>]

Disclaimer & Data Validity:

The information provided in this document is for Research Use Only (RUO) and is strictly not intended for diagnostic or therapeutic procedures. While BenchChem strives to provide accurate protocols, we make no warranties, express or implied, regarding the fitness of this product for every specific experimental setup.

Technical Support: The protocols provided are for reference purposes. Unsure if this reagent suits your experiment?

Need Industrial/Bulk Grade? [Request Custom Synthesis Quote](#)

BenchChem

Our mission is to be the trusted global source of essential and advanced chemicals, empowering scientists and researchers to drive progress in science and industry.

Contact

Address: 3281 E Guasti Rd
Ontario, CA 91761, United States
Phone: (601) 213-4426
Email: info@benchchem.com

[Contact our Ph.D. Support Team for a compatibility check](#)