

# Scalable Manufacturing Methods for Methoxybenzoyl Piperazine Derivatives: Application Notes & Protocols

**Author:** BenchChem Technical Support Team. **Date:** April 2026

## Compound of Interest

Compound Name:	1-(4-Methoxybenzoyl)piperazine trifluoroacetate
CAS No.:	1185479-65-5
Cat. No.:	B3088648

[Get Quote](#)

## Introduction & Process Rationale

Piperazine is a privileged scaffold in medicinal chemistry, forming the core of numerous central nervous system (CNS), cardiovascular, and anti-cancer agents[1]. Methoxybenzoyl piperazine derivatives—such as the anti-anginal drug Trimetazidine (1-(2,3,4-trimethoxybenzyl)piperazine) and various neuroleptic precursors—represent a highly valuable class of pharmacophores[2][3].

However, the symmetrical nature of the piperazine diamine presents a fundamental process chemistry challenge: achieving high selectivity for mono-substitution (amidation or alkylation) over di-substitution. While bench-scale synthesis often relies on atom-inefficient protecting group strategies (e.g., Boc-protection) to force selectivity[1], commercial scale-up requires direct, protecting-group-free methodologies.

As a Senior Application Scientist, I have structured this guide to detail two field-proven, scalable methodologies for synthesizing methoxybenzoyl piperazines: an optimized batch

amidation process and a state-of-the-art continuous flow alkylation process.

## Mechanistic Control of Piperazine Functionalization

When reacting piperazine with an electrophile like methoxybenzoyl chloride, reaction kinetics dictate the product distribution. The initial acylation is rapid, but the resulting mono-amide remains nucleophilic. If local concentrations of the electrophile exceed the available piperazine due to poor mixing, the di-amide impurity forms rapidly.

In batch manufacturing, this is mitigated by adding the acid chloride dropwise to a large molar excess of piperazine under highly controlled cryogenic or ice-cooled conditions (0–5 °C)[4].

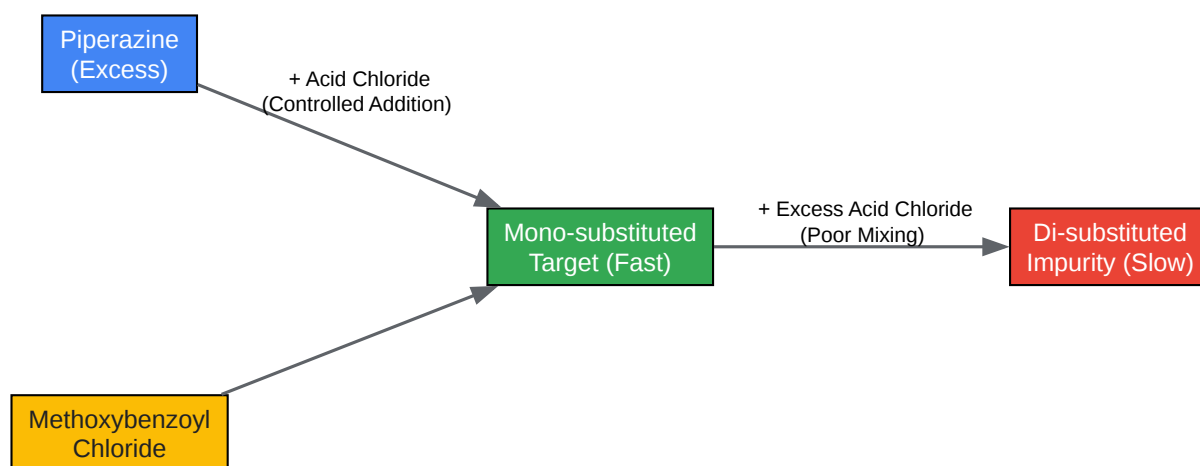

[Click to download full resolution via product page](#)

Kinetic pathways in piperazine acylation highlighting mono- vs di-substitution.

While excess piperazine drives pseudo-first-order kinetics favoring the mono-adduct, continuous flow chemistry offers a superior alternative for larger scales by ensuring instantaneous mixing and precise stoichiometric control, effectively eliminating the back-mixing that leads to di-alkylation[5].

## Protocol 1: Scalable Batch Mono-Amidation

Target: N-(4-Methoxybenzoyl)piperazine Application: Precursor for neuroleptic and analgesic agents.

This protocol utilizes a stoichiometric excess of piperazine to ensure mono-selectivity. It substitutes traditional dichloromethane (DCM) with 2-Methyltetrahydrofuran (2-MeTHF) for improved phase separation and green chemistry compliance.

### Step-by-Step Methodology:

- **Reactor Preparation:** Charge a 5 L jacketed glass reactor with piperazine (430 g, 5.0 mol, 5.0 eq) and 2-MeTHF (2.5 L). Stir at 250 rpm until complete dissolution.
- **Thermal Control:** Circulate coolant to bring the internal reactor temperature to 0–5 °C.
  - **Causality:** Lower temperatures suppress the thermal energy available to overcome the activation barrier of the secondary acylation, thereby maximizing mono-selectivity[4].\*
- **Electrophile Addition:** Dissolve 4-methoxybenzoyl chloride (170.6 g, 1.0 mol, 1.0 eq) in 2-MeTHF (500 mL). Feed this solution into the reactor via a dosing pump at a rate of 8-10 mL/min.
  - **Causality:** Slow addition ensures the electrophile is instantly quenched by the massive excess of piperazine, preventing local pooling of the acid chloride which would otherwise trigger di-amidation.\*
- **Aging:** Post-addition, allow the reaction to warm to 20 °C and age for 2 hours. Monitor conversion via HPLC.
- **Aqueous Workup:** Add 1 L of deionized water. The unreacted excess piperazine partitions entirely into the aqueous phase, while the mono-amide remains in the 2-MeTHF. Wash the organic layer twice with 500 mL of water, dry over Na<sub>2</sub>SO<sub>4</sub>, and concentrate under reduced pressure to yield the product.

## Protocol 2: Continuous Flow Synthesis of Trimetazidine

Target: 1-(2,3,4-Trimethoxybenzyl)piperazine (Trimetazidine) Application: Active Pharmaceutical Ingredient (API) for angina pectoris.

Continuous flow reactors provide superior heat and mass transfer, allowing highly exothermic reactions to be run safely at elevated temperatures (process intensification)[1][5]. This protocol describes the N-alkylation of piperazine using a microreactor setup.

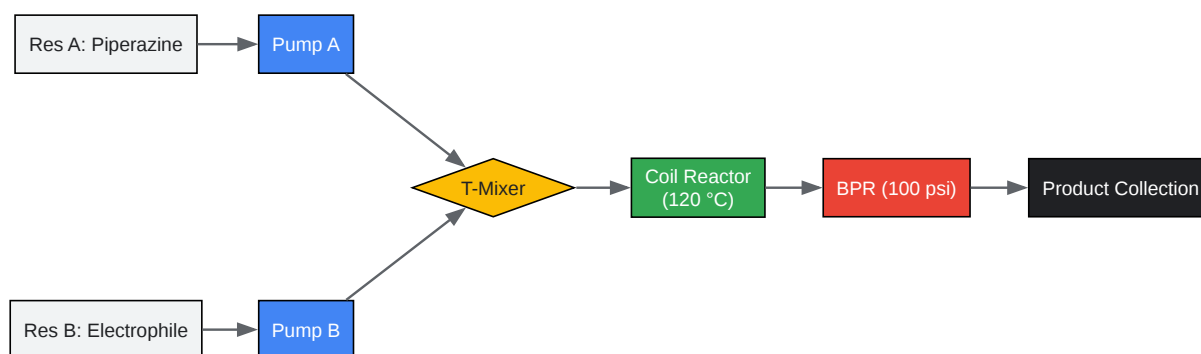

[Click to download full resolution via product page](#)

Continuous flow reactor configuration for scalable synthesis of Trimetazidine.

### Step-by-Step Methodology:

- System Priming: Flush the flow system (PFA tubing, 10 mL internal volume) with ethanol at 2.0 mL/min. Set the back-pressure regulator (BPR) to 100 psi.
  - Causality: The BPR pressurizes the system, allowing the ethanol solvent to be heated well above its atmospheric boiling point without outgassing, ensuring a stable, single-phase liquid flow[5].\*
- Reagent Preparation:

- Stream A: Piperazine (2.0 M in EtOH).
- Stream B: 2,3,4-Trimethoxybenzyl chloride (1.0 M in EtOH).
- Reaction Execution: Set HPLC Pump A to 1.0 mL/min and Pump B to 1.0 mL/min. The streams converge at a PEEK T-mixer and enter a coil reactor heated to 120 °C.
  - Causality: The 2:1 stoichiometric ratio combined with rapid diffusion in the micro-channels ensures high mono-selectivity. The 120 °C temperature accelerates the alkylation, reducing the required residence time to exactly 5.0 minutes.\*
- Collection & Isolation: Collect the reactor effluent in a flask cooled in an ice bath. The product is isolated by evaporating the ethanol, dissolving the residue in ethyl acetate, and precipitating the API as a dihydrochloride salt using HCl gas[3].

## Quantitative Process Comparison

To justify the transition from batch to flow for late-stage development, the table below compares the critical process parameters (CPPs) and key performance indicators (KPIs) for the synthesis of Trimetazidine.

Parameter	Traditional Batch Process	Continuous Flow Process
Stoichiometry (Piperazine : Electrophile)	5.0 : 1.0	2.0 : 1.0
Operating Temperature	0 °C to 20 °C	120 °C (Pressurized)
Reaction Time / Residence Time	4 - 6 Hours	5.0 Minutes
Di-alkylated Impurity Profile	3.5%	< 0.5%
Isolated Yield	78%	92%
Space-Time Yield (STY)	~0.05 kg L <sup>-1</sup> h <sup>-1</sup>	> 1.2 kg L <sup>-1</sup> h <sup>-1</sup>

## References

- Synthesis of N-(3-methoxybenzoyl)-piperazine PrepChem.com [[Link](#)]

- Potential neuroleptics of the orthopramide series; Synthesis of N-substituted 5-(aminosulfonyl)-2-methoxybenzamides Scilit [[Link](#)]
- Continuous Flow Chemistry for Scalable Drug Synthesis AZoLifeSciences[[Link](#)]
- Piperazine Derivatives: A Privileged Scaffold in Modern Synthesis and Medicinal Chemistry National Institutes of Health (NIH)[[Link](#)]
- Synthesis, molecular modeling, and biological evaluation of novel imatinib derivatives as anticancer agents TÜBİTAK Academic Journals[[Link](#)]

### Need Custom Synthesis?

BenchChem offers custom synthesis for rare earth carbides and specific isotopic labeling.

Email: [info@benchchem.com](mailto:info@benchchem.com) or [Request Quote Online](#).

## Sources

- 1. Piperazine Derivatives: A Privileged Scaffold in Modern Synthesis and Medicinal Chemistry - PMC [[pmc.ncbi.nlm.nih.gov](https://pubmed.ncbi.nlm.nih.gov)]
- 2. [scilit.com](https://scilit.com) [[scilit.com](https://scilit.com)]
- 3. [journals.tubitak.gov.tr](https://journals.tubitak.gov.tr) [[journals.tubitak.gov.tr](https://journals.tubitak.gov.tr)]
- 4. [prepchem.com](https://prepchem.com) [[prepchem.com](https://prepchem.com)]
- 5. [azolifesciences.com](https://azolifesciences.com) [[azolifesciences.com](https://azolifesciences.com)]
- To cite this document: BenchChem. [Scalable Manufacturing Methods for Methoxybenzoyl Piperazine Derivatives: Application Notes & Protocols]. BenchChem, [2026]. [Online PDF]. Available at: [<https://www.benchchem.com/product/b3088648/docs#scalable-manufacturing-methods-for-methoxybenzoyl-piperazine-derivatives-application-notes-protocols>]

---

### Disclaimer & Data Validity:

The information provided in this document is for Research Use Only (RUO) and is strictly not intended for diagnostic or therapeutic procedures. While BenchChem strives to provide

accurate protocols, we make no warranties, express or implied, regarding the fitness of this product for every specific experimental setup.

**Technical Support:** The protocols provided are for reference purposes. Unsure if this reagent suits your experiment?

**Need Industrial/Bulk Grade?** [Request Custom Synthesis Quote](#)

## BenchChem

Our mission is to be the trusted global source of essential and advanced chemicals, empowering scientists and researchers to drive progress in science and industry.

### Contact

Address: 3281 E Guasti Rd

Ontario, CA 91761, United States

Phone: (601) 213-4426

Email: [info@benchchem.com](mailto:info@benchchem.com)

[Contact our Ph.D. Support Team for a compatibility check](#)