

Application Note: Precision Solution Processing of Small Molecule Hole Transport Layers

Author: BenchChem Technical Support Team. **Date:** April 2026

Compound of Interest

Compound Name: 2,6-Bis[(E)-4-(diphenylamino)styryl]naphthalene

CAS No.: 1032556-63-0

Cat. No.: B3075560

[Get Quote](#)

Focus Material: Spiro-OMeTAD and Derivatives Context: Perovskite Solar Cells (PSCs) and n-i-p Optoelectronic Architectures

Executive Summary & Scope

This guide details the solution-phase engineering of small molecule Hole Transport Layers (HTLs), specifically focusing on 2,2',7,7'-Tetrakis[N,N-di(4-methoxyphenyl)amino]-9,9'-spirobifluorene (Spiro-OMeTAD). Unlike polymeric HTLs (e.g., PTAA), small molecules suffer from high crystallization tendencies and low intrinsic carrier mobility (

).

Successful deposition requires a tripartite approach:

- Chemical Doping: Increasing hole density via oxidative radicals.
- Kinetic Control: Managing solvent evaporation to prevent macro-crystallization.

- Post-Process Activation: Controlled oxidation to align Fermi levels.

Target Audience: Material Scientists and Process Engineers transitioning from lab-scale spin coating to scalable blade coating.

Ink Engineering & Formulation

The performance of an HTL is dictated by the "Ink Age" and the precise ratio of dopants. Spiro-OMeTAD is an insulator until doped.

The Standard "Recipe" (High-Efficiency Baseline)

Note: All preparations must occur in a Nitrogen-filled Glovebox (

), though the final oxidation requires air.

Component	Role	Standard Conc.	Solvent
Spiro-OMeTAD	Host Matrix	72.3 mg/mL	Chlorobenzene (CB)
Li-TFSI	p-Dopant (Conductivity)	520 mg/mL	Acetonitrile (ACN)
tBP (4-tert-butylpyridine)	Morphology/Energy Aligner	Pure Liquid	N/A
FK209 Co(III) (Optional)	Instant Oxidizer	300 mg/mL	Acetonitrile (ACN)

Mixing Protocol (Critical Order of Addition)

Do not mix all components simultaneously. The hygroscopic nature of Li-TFSI requires it to be added last or strictly controlled to prevent moisture uptake before film formation.

- Dissolve Host: Dissolve Spiro-OMeTAD in Chlorobenzene. Heat at 60°C for 30 mins. Filter (0.45 µm PTFE).
- Add tBP: Add 28.8 µL of tBP per 1 mL of Spiro solution. Mechanism: tBP prevents Li-TFSI aggregation and suppresses phase separation.[1]

- Add Li-TFSI: Add 17.5 μ L of Li-TFSI stock solution.
- Add Cobalt (Optional): If using FK209, add 8-10 μ L of stock. Benefit: Reduces oxidation time from 12h to 0h.

The Doping Mechanism (Visualization)

The following diagram illustrates why oxygen or cobalt is required. Li-TFSI alone does not dope Spiro; it requires an oxidation trigger.

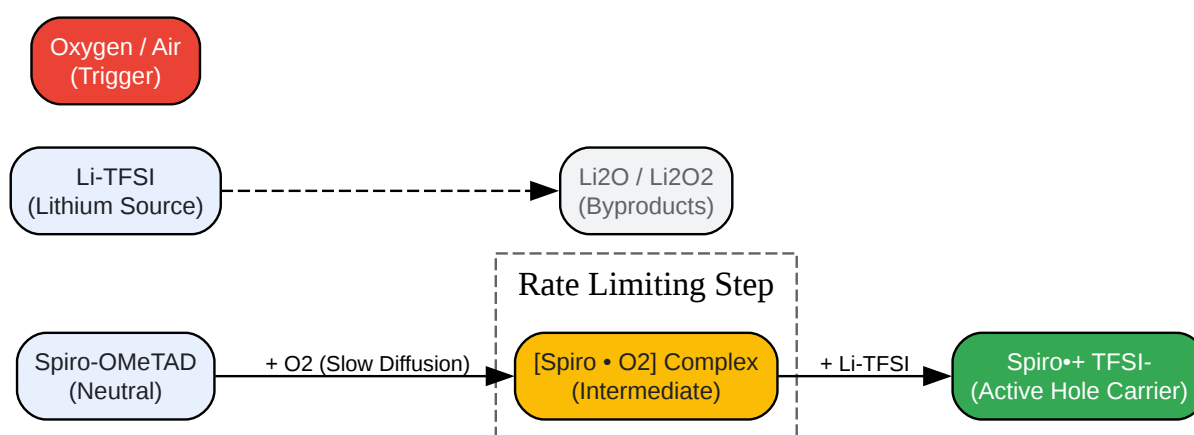

[Click to download full resolution via product page](#)

Deposition Protocols

Lab-Scale: Dynamic Spin Coating

Why Dynamic? Static dispensing (placing ink on a stationary substrate) allows the solvent to interact with the underlying perovskite layer for too long, potentially dissolving it. Dynamic dispensing minimizes contact time before evaporation.

Protocol:

- Substrate: Perovskite film on FTO/ITO.
- Spin Settings:
 - Speed: 3000 - 4000 RPM

- Acceleration: 2000 RPM/s (High acceleration is crucial for uniformity)
- Time: 30 seconds
- Dispense:
 - Start the spinner.[2][3]
 - Wait for speed to stabilize (approx. 2-3 seconds).
 - Drop 25-30 μL of solution onto the center of the spinning substrate.
- Edge Cleaning: Immediately wipe edges with a swab dipped in Chlorobenzene to ensure electrical contact for the top electrode.

Industrial Scale: Air-Assisted Blade Coating

Challenge: The "Coffee Ring Effect" and slow drying lead to large crystallites that shunt the device. Solution: Heated substrate + Nitrogen Knife.

Protocol:

- Solvent Swap: Replace Chlorobenzene with Toluene or Xylene (lower toxicity, better wetting on large areas).
- Substrate Temp: Heat stage to 60°C - 70°C.
- Blade Gap: 100 μm .
- Speed: 10 - 25 mm/s.
- Air Knife: Apply a laminar flow of

(20 psi) immediately behind the blade. This forces rapid solvent evaporation, freezing the morphology before crystals can grow large.

The Critical Control Point: Oxidation (Aging)

If you deposit the metal electrode (Gold/Silver) immediately after spin coating, the device will have low Fill Factor (FF) and high series resistance. The film must "breathe."

The Standard Aging Protocol:

- Store films in a Dry Air Desiccator (Humidity < 20%).
 - Note: Do not use inert gas (Nitrogen). Oxygen is a reactant.[4][5]
- Duration: 12 - 16 hours (Overnight).
- Acceleration (HPOT Method): Exposing films to pure
at 60°C can reduce this time to < 5 hours.

QC Check: Measure conductivity of a reference glass/Spiro sample.

- Target:
.
- Visual: The film should darken slightly (oxidized Spiro radical has a distinct absorption at ~520 nm).

Troubleshooting & QC Matrix

Defect / Symptom	Probable Cause	Corrective Action
Hazy / Milky Film	Moisture uptake by Li-TFSI	Use fresh anhydrous solvents; filter solution; keep Li-TFSI in desiccator.
Pinholes (SEM)	Poor wetting on Perovskite	Add trace surfactant or switch to Dynamic Spin Coating.
Low Voc	tBP evaporation	tBP is volatile. Do not vacuum dry the film before electrode deposition.
S-Shaped JV Curve	Insufficient Doping/Oxidation	Increase aging time in dry air; check Li-TFSI concentration.
Device instability	Li ⁺ migration	Use FK209 (Cobalt) to reduce reliance on high Li-TFSI concentrations.

Process Workflow Diagram

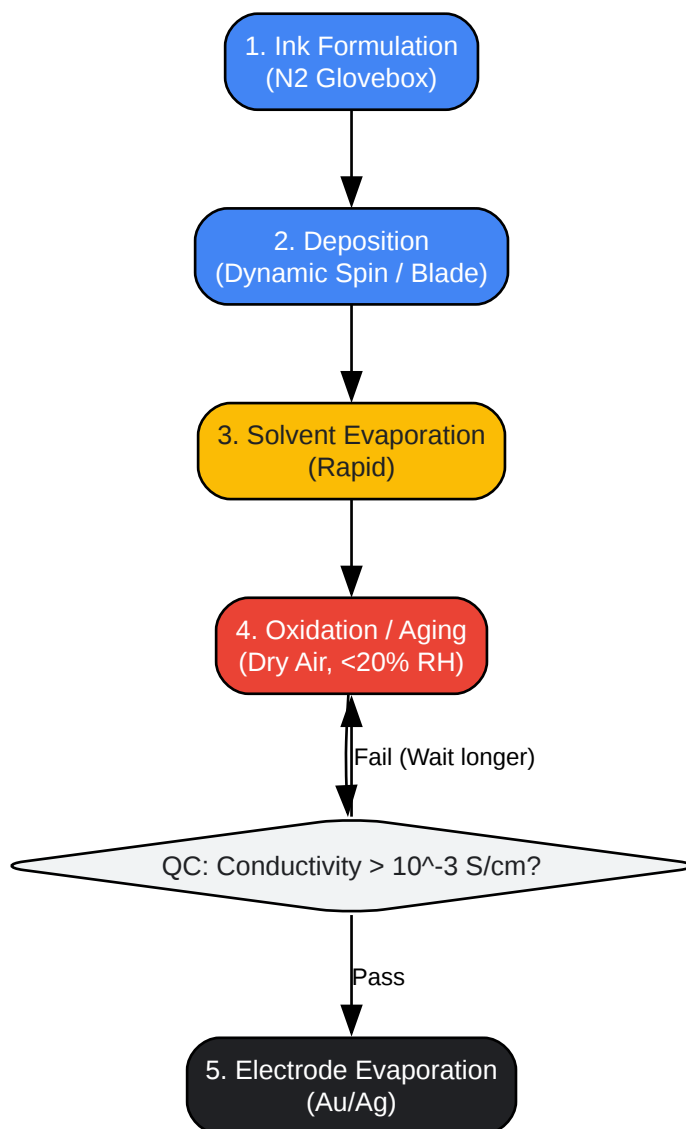

[Click to download full resolution via product page](#)

References

- Spiro-OMeTAD Oxidation Mechanism & HPOT Zhang, H., et al. "Hot Pure Oxygen Accelerated Oxidation of Spiro-OMeTAD for Efficient Perovskite Solar Cells." ACS Energy Letters (2024).[6]
- Doping Chemistry (Li-TFSI & tBP) Ouedraogo, N., et al.[1][4][7] "Oxidation of Spiro-OMeTAD in High-Efficiency Perovskite Solar Cells." ACS Applied Materials & Interfaces (2022).[8]
- Blade Coating & Scalable Fabrication Deng, Y., et al.[9] "Scalable Blade Coating: A Technique Accelerating the Commercialization of Perovskite-Based Photovoltaics." [10] Small

Methods (2018).

- Dynamic vs. Static Spin Coating Du, J., et al.[11] "Impacts of the Hole Transport Layer Deposition Process on Buried Interfaces in Perovskite Solar Cells." *Frontiers in Chemistry* (2020).
- Cobalt Co-Doping (FK209) Xu, J., et al. "Perovskite-filled membranes for flexible and large-area perovskite solar cells." *Nature Communications* (2018). (Contextualizes Co-dopant usage for stability).

Need Custom Synthesis?

BenchChem offers custom synthesis for rare earth carbides and specific isotopic labeling.

Email: info@benchchem.com or [Request Quote Online](#).

Sources

- 1. html.rhhz.net [html.rhhz.net]
- 2. ossila.com [ossila.com]
- 3. benchchem.com [benchchem.com]
- 4. mdpi.com [mdpi.com]
- 5. pubs.rsc.org [pubs.rsc.org]
- 6. pubs.acs.org [pubs.acs.org]
- 7. A Novel Organic Dopant for Spiro-OMeTAD in High-Efficiency and Stable Perovskite Solar Cells - PMC [pmc.ncbi.nlm.nih.gov]
- 8. Oxidation of Spiro-OMeTAD in High-Efficiency Perovskite Solar Cells - PubMed [pubmed.ncbi.nlm.nih.gov]
- 9. Triple-cation perovskite solar cells fabricated by a hybrid PVD/blade coating process using green solvents - PMC [pmc.ncbi.nlm.nih.gov]
- 10. researchgate.net [researchgate.net]
- 11. researchgate.net [researchgate.net]
- To cite this document: BenchChem. [Application Note: Precision Solution Processing of Small Molecule Hole Transport Layers]. BenchChem, [2026]. [Online PDF]. Available at:

[\[https://www.benchchem.com/product/b3075560/docs#application-note-precision-solution-processing-of-small-molecule-hole-transport-layers\]](https://www.benchchem.com/product/b3075560/docs#application-note-precision-solution-processing-of-small-molecule-hole-transport-layers)

Disclaimer & Data Validity:

The information provided in this document is for Research Use Only (RUO) and is strictly not intended for diagnostic or therapeutic procedures. While BenchChem strives to provide accurate protocols, we make no warranties, express or implied, regarding the fitness of this product for every specific experimental setup.

Technical Support: The protocols provided are for reference purposes. Unsure if this reagent suits your experiment?

Need Industrial/Bulk Grade? [Request Custom Synthesis Quote](#)

BenchChem

Our mission is to be the trusted global source of essential and advanced chemicals, empowering scientists and researchers to drive progress in science and industry.

Contact

Address: 3281 E Guasti Rd
Ontario, CA 91761, United States
Phone: (601) 213-4426
Email: info@benchchem.com

[Contact our Ph.D. Support Team for a compatibility check](#)