

Technical Support Center: Synthesis of Halogenated Corticosteroids

Author: BenchChem Technical Support Team. **Date:** April 2026

Compound of Interest

Compound Name: *17,21-Dihydroxypregna-1,4,9(11)-triene-3,20-dione*

CAS No.: *10184-69-7*

Cat. No.: *B3073894*

[Get Quote](#)

Welcome to the Advanced Synthesis Support Hub. Operator: Dr. A. Vance, Senior Application Scientist
Status: Online Ticket ID: HAL-CORT-2024-X9[1]

Mission Statement

You have entered a high-level troubleshooting environment designed for process chemists and medicinal researchers. The synthesis of halogenated corticosteroids (e.g., Dexamethasone, Betamethasone, Mometasone) is governed by a delicate balance of stereoelectronic effects. Our goal is not just to provide a recipe, but to diagnose the root cause of failure modes—specifically regioselectivity loss, stereochemical drift, and elimination side-reactions.[1]

Module 1: C9-Fluorination (The Epoxide Route)

Context: The introduction of fluorine at the C9 position is pivotal for increasing glucocorticoid potency (approx. 10x). This is almost exclusively achieved via the opening of a 9

,11

-epoxide using an HF source.[1]

Q1: My 9,11-epoxide opening reaction is yielding significant amounts of the

elimination product instead of the desired 9

-F, 11

-OH. What is driving this?

Diagnosis: You are witnessing a competition between nucleophilic attack (SN1-like) and E1 elimination. The opening of the 9

,11

-epoxide proceeds through a transition state with significant carbocation character at C9.

- The Mechanism: The epoxide oxygen is protonated, weakening the C9-O bond. Fluoride must attack C9 from the
-face (trans-diaxial opening).[1]
- The Failure Mode: If the fluoride source is too weak or the medium is too acidic without sufficient nucleophile activity, the C9 carbocation stabilizes itself by eliminating a proton from C8 or C12, reforming the
double bond (often observed as the "triene" impurity in conjugated systems).

Troubleshooting Protocol:

- Check HF Source: Switch from aqueous HF to HF-Urea (Olah's Reagent) or HF-Pyridine.[1]
These provide a higher concentration of active fluoride ion (
) relative to protons compared to aqueous HF, favoring substitution over elimination [1].[1]
- Temperature Control: Maintain the reaction between -10°C and 0°C. Higher temperatures increase the entropy-favored elimination pathway.[1]

- Water Content: Ensure the system is anhydrous. Water competes as a nucleophile, leading to the 9

,11

-diol impurity, which is extremely difficult to separate from the fluorohydrin.

Q2: I am observing a "Wagner-Meerwein" type rearrangement product. How do I prevent this?

Diagnosis: This occurs when the C9 carbocation lifetime is prolonged, allowing migration of the C18-methyl group or skeletal rearrangement (C-nor/D-homo transformation).[1] This is often catalyzed by super-acidic conditions or low nucleophile availability.

Corrective Action:

- Buffer the System: Use a Lewis base buffer (e.g., THF or excess pyridine if using HF-Pyridine) to modulate acidity.
- Kinetic Control: Quench the reaction immediately upon consumption of the epoxide. Do not let the reaction "soak" to improve yield; this invariably increases skeletal rearrangement impurities [2].

Visualization: C9-Fluorination Pathways

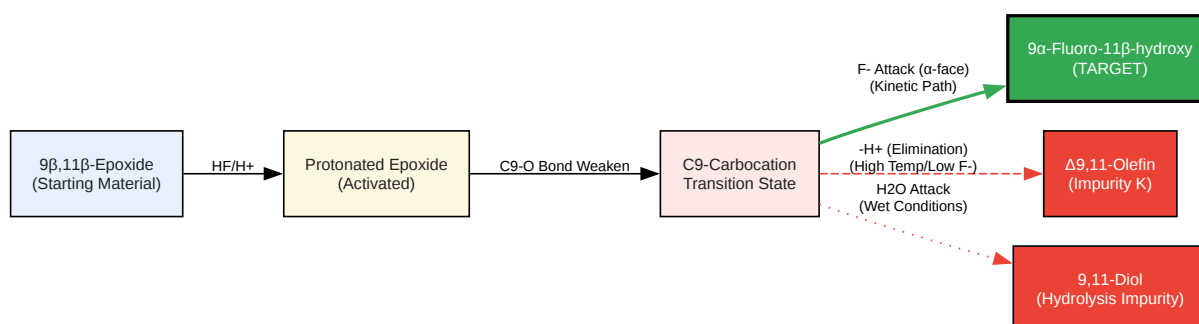

[Click to download full resolution via product page](#)

Figure 1: Mechanistic divergence in the acid-catalyzed opening of steroidal 9,11-epoxides. Success depends on maximizing the green pathway (fluoride attack) while suppressing elimination and hydrolysis.

Module 2: C6-Fluorination (Stereoselectivity)

Context: C6-fluorination (e.g., Flumethasone, Paramethasone) is typically achieved via electrophilic fluorination of a C3-enol ether or enol acetate.^[1]

Q3: I used Selectfluor on the enol ether, but I have a 60:40 mixture of 6

-F (unwanted) to 6

-F (wanted). Is my reagent defective?

Diagnosis: No, the reagent is working correctly. Electrophilic fluorination of steroids is kinetically controlled to favor the 6

-isomer due to the "upper-face" attack preference (steric approach control). The 6

-isomer is the thermodynamic product (equatorial fluorine).

The Fix: Acid-Catalyzed Epimerization You cannot rely on the fluorination step alone for stereocontrol. You must include a post-fluorination equilibration step.^[1]

Protocol:

- Fluorination: React substrate with Selectfluor in Acetonitrile/Water.^[1] Isolate the crude mixture (rich in 6).
- Epimerization: Dissolve the crude residue in glacial acetic acid.
- Catalyst: Add anhydrous HCl (gas or dissolved in dioxane) or HBr.
- Mechanism: The acid protonates the ketone, allowing enolization. The C6-F bond breaks and reforms to the thermodynamically more stable equatorial (6

) position.

- Monitoring: Monitor via HPLC until the

:

ratio shifts from ~60:40 to <5:95 [3].

Module 3: C21-Halogenation (Side Chain Engineering)

Context: For compounds like Mometasone Furoate, a chlorine atom is introduced at C21.[1][2][3][4][5] This is usually a nucleophilic displacement of a leaving group (Mesylate/Tosylate).

Q4: When trying to install the C21-Cl, I am getting chlorination at C11 or decomposition. Why?

Diagnosis: If you are using Methanesulfonyl chloride (MsCl) to activate the C21-OH, the C11-OH (if free) is also nucleophilic, especially if it is an 11

-OH. Furthermore, the 17

-OH can participate in Mattox rearrangement or cyclic orthoester formation.[1]

Strategic Solution:

- Sequence Matters: Do not attempt C21-chlorination on a molecule with a free 11 -OH if possible.
 - Route A: Perform C21-chlorination before opening the 9,11-epoxide.[1] The epoxide protects the C11 position.
 - Route B: Use a highly selective chlorinating agent like Vilsmeier reagent (DMF/POCl₃) which is more selective for primary alcohols (C21) over secondary hindered alcohols (C11) [4].
- Displacement Conditions: Use LiCl in DMF or NMP at 60-80°C for the displacement of the C21-mesylate.[1] Avoid higher temperatures which promote elimination to the

species.

Summary of Critical Parameters

Parameter	C9-Fluorination (Epoxide)	C6-Fluorination (Selectfluor)	C21-Chlorination (Displacement)
Key Reagent	HF-Urea / HF-Pyridine	Selectfluor / NFSI	LiCl / MsCl
Major Impurity	(Elimination)	6 -Fluoro isomer	or C11-Mesylate
Critical Control	Temp < 0°C; Anhydrous	Acid Epimerization Step	Protection of C11-OH
Stereochemistry	Anti-Markovnikov opening	Kinetic () vs Thermo ()	SN2 Inversion (at C21)

Visualization: C6-Fluorination & Epimerization Workflow

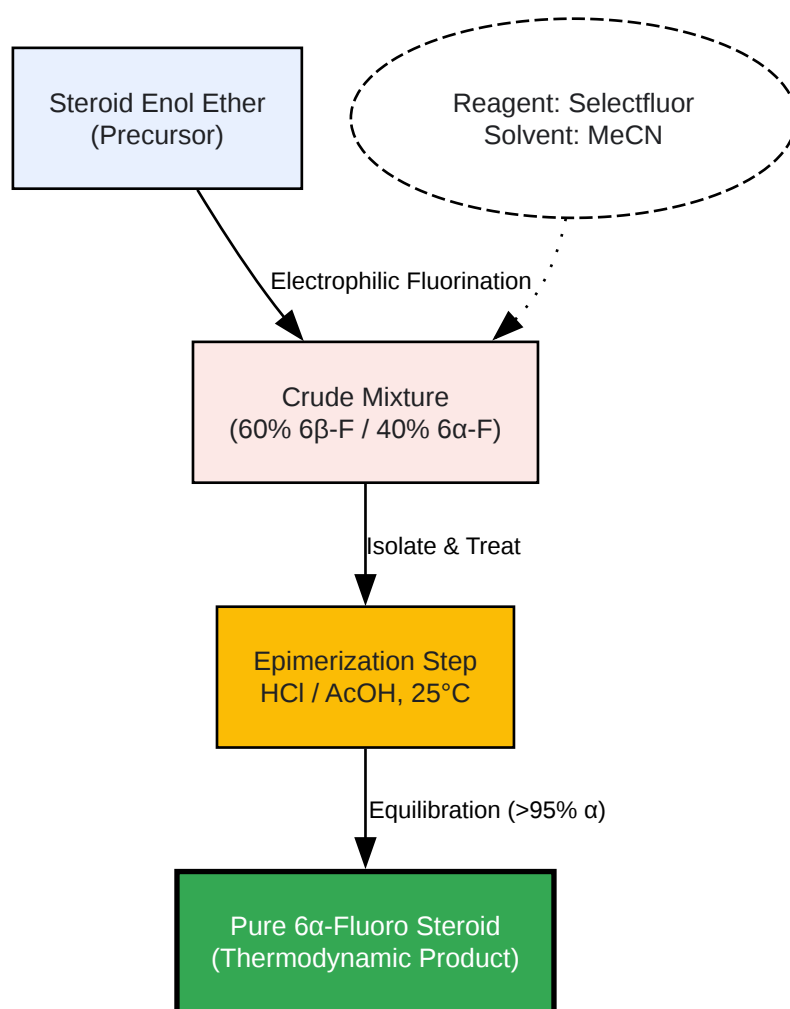

[Click to download full resolution via product page](#)

Figure 2: The standard industrial workflow for C6-fluorination.[1] Note that the initial reaction is not stereoselective; the process relies on a chemical "correction" step (epimerization).

References

- Olah, G. A., et al. (1973). "Synthetic Methods and Reactions. I. Preparation and Cleavage of Epoxides with Pyridinium Poly(hydrogen fluoride)." *Journal of Organic Chemistry*.
- Fried, J., & Sabo, E. F. (1954). "Synthesis of 17
-hydroxycorticosterone and its 9
-halo derivatives from 11-epi-17

-hydroxycorticosterone." Journal of the American Chemical Society.[6]

- Hodgson, D. R. W., et al. (2020). "Kinetics of Electrophilic Fluorination of Steroids and Epimerisation of Fluorosteroids." Chemistry – A European Journal.[1]
- Fu, X., et al. (2001).

corticosteroids." Tetrahedron Letters.

- Gouyette, A. (2023).[7] "Multi-Gram Scale Synthesis and Characterization of Mometasone Furoate EP Impurity C." Molecules.

Need Custom Synthesis?

BenchChem offers custom synthesis for rare earth carbides and specific isotopic labeling.

Email: info@benchchem.com or [Request Quote Online](#).

Sources

- [1. Mometasone furoate synthesis - chemicalbook \[chemicalbook.com\]](#)
- [2. data.epo.org \[data.epo.org\]](#)
- [3. Multi-Gram Scale Synthesis and Characterization of Mometasone Furoate EP Impurity C - PMC \[pmc.ncbi.nlm.nih.gov\]](#)
- [4. data.epo.org \[data.epo.org\]](#)
- [5. WO1995032989A1 - Process for preparing 9,11 and 21-chloro corticosteroids - Google Patents \[patents.google.com\]](#)
- [6. EP0105650B1 - Process for preparing 9,11-epoxy steroids from 9 alpha-substituted-11-hydroxy steroids - Google Patents \[patents.google.com\]](#)
- [7. sielc.com \[sielc.com\]](#)
- To cite this document: BenchChem. [Technical Support Center: Synthesis of Halogenated Corticosteroids]. BenchChem, [2026]. [Online PDF]. Available at: [\[https://www.benchchem.com/product/b3073894/docs#technical-support-center-synthesis-of-halogenated-corticosteroids\]](https://www.benchchem.com/product/b3073894/docs#technical-support-center-synthesis-of-halogenated-corticosteroids)

Disclaimer & Data Validity:

The information provided in this document is for Research Use Only (RUO) and is strictly not intended for diagnostic or therapeutic procedures. While BenchChem strives to provide accurate protocols, we make no warranties, express or implied, regarding the fitness of this product for every specific experimental setup.

Technical Support: The protocols provided are for reference purposes. Unsure if this reagent suits your experiment?

Need Industrial/Bulk Grade? [Request Custom Synthesis Quote](#)

BenchChem

Our mission is to be the trusted global source of essential and advanced chemicals, empowering scientists and researchers to drive progress in science and industry.

Contact

Address: 3281 E Guasti Rd
Ontario, CA 91761, United States
Phone: (601) 213-4426
Email: info@benchchem.com

[Contact our Ph.D. Support Team for a compatibility check](#)