

Technical Support Center: Solubility & Handling of Quinoline-3-carbohydrazide[1]

Author: BenchChem Technical Support Team. **Date:** April 2026

Compound of Interest

Compound Name: 8-Fluoro-4-hydroxyquinoline-3-carbohydrazide

CAS No.: 1018127-67-7

Cat. No.: B3073667

[Get Quote](#)

The "Brick Dust" Challenge: Understanding Your Molecule

Welcome to the technical guide for Quinoline-3-carbohydrazide. If you are struggling to dissolve this compound, you are not alone. This scaffold exhibits classic "brick dust" characteristics: high melting points (often $>220^{\circ}\text{C}$) and poor solubility in common low-boiling solvents.

The Chemical Root Cause:

-

Stacking: The planar quinoline ring facilitates strong aromatic stacking interactions in the crystal lattice.

- Hydrogen Bonding: The carbohydrazide moiety (

) acts as both a hydrogen bond donor and acceptor, creating a rigid intermolecular network that resists solvation.

This guide provides field-proven protocols to overcome these energy barriers without compromising the chemical integrity of your sample.

Solvent Compatibility Matrix

Use this matrix to select the correct solvent system based on your experimental goal. Data is derived from standard synthesis and handling protocols for quinoline-3-carbohydrazide and its derivatives.

Solvent Class	Specific Solvent	Solubility Rating	Application	Notes
Polar Aprotic	DMSO	High	Bio-assays, NMR	Gold Standard. Dissolves readily at RT.
Polar Aprotic	DMF	High	Synthesis, Recrystallization	Good alternative to DMSO; easier to remove by washing.
Polar Protic	Ethanol/Methanol	Low (Cold) / High (Hot)	Recrystallization	The primary solvent for purification. Requires reflux.
Non-Polar	Diethyl Ether	Insoluble	Washing / Precipitation	Used to wash away impurities; product will not dissolve.
Chlorinated	DCM / Chloroform	Moderate to Low	Extraction	Often insufficient for fully dissolving the solid; avoid for stock solutions.
Aqueous	Water / PBS	Insoluble	Biological Media	Warning: Will precipitate immediately upon addition if not handled correctly.

Workflow: Recrystallization & Purification[2]

The most common issue reported is the inability to purify the compound due to its refusal to dissolve in standard recrystallization solvents like cold ethanol.

Protocol A: The "Reflux" Method (Standard)

Best for: Removing unreacted hydrazine or ester starting materials.

- Suspension: Place crude solid in Ethanol (approx. 10-15 mL per gram). It will look like a suspension.
- Heat to Reflux: Heat the mixture to boiling (). The solid should dissolve completely.
 - Troubleshooting: If it does not dissolve after 10 mins of reflux, add DMF dropwise (0.5 mL at a time) through the condenser until clear.
- Cooling: Remove heat and allow to cool slowly to Room Temperature (RT).
- Crystallization: The hydrazide will crystallize out as white/pale-yellow needles.
- Filtration: Filter and wash with cold ethanol.

Protocol B: The Solvent/Anti-Solvent Method (For Stubborn Derivatives)

Best for: Highly substituted derivatives that are insoluble in boiling ethanol.

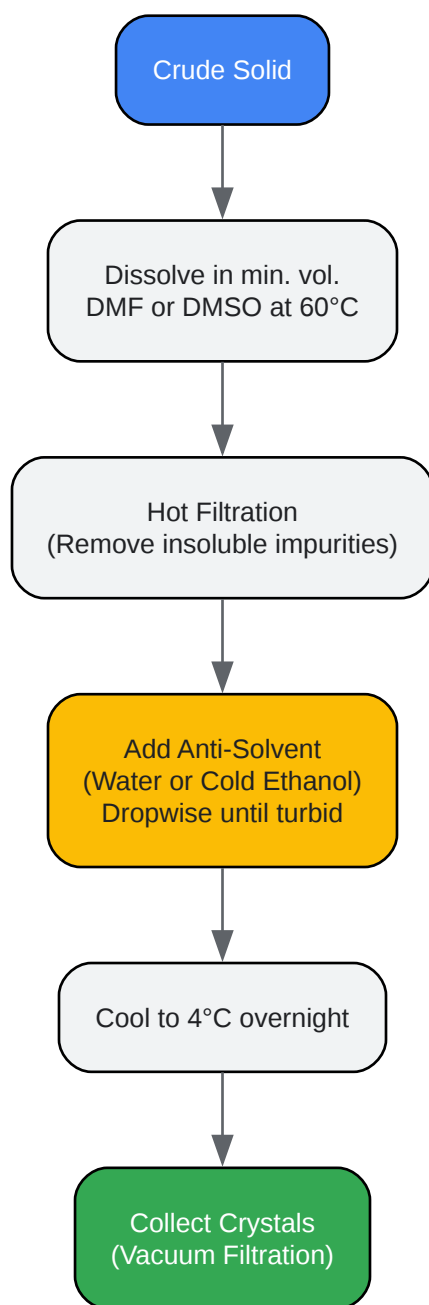

[Click to download full resolution via product page](#)

Figure 1: Solvent/Anti-Solvent purification logic for low-solubility quinoline derivatives.

Biological Assay Preparation (Preventing "DMSO Shock")

The Problem: When you add a DMSO stock solution of quinoline-3-carbohydrazide to aqueous media (PBS, Cell Media), the hydrophobic quinoline ring causes immediate microprecipitation.

This leads to false negatives in drug screening.

The Solution: Kinetic Solubility Management.

Step-by-Step Protocol

- Prepare Master Stock: Dissolve compound in 100% DMSO to 10 mM.
 - Verification: Solution must be perfectly clear. Sonicate if necessary.[\[1\]](#)[\[2\]](#)
- Intermediate Dilution (The Critical Step):
 - Do NOT add the 10 mM stock directly to the media.
 - Perform serial dilutions in DMSO first (e.g., down to 1 mM, 0.1 mM in DMSO).
- Final Addition:
 - Add the diluted DMSO stock to the aqueous buffer under rapid agitation (vortexing).
 - Rule of 1%: Ensure final DMSO concentration is (v/v).
 - Example: Add

of stock to

of media.

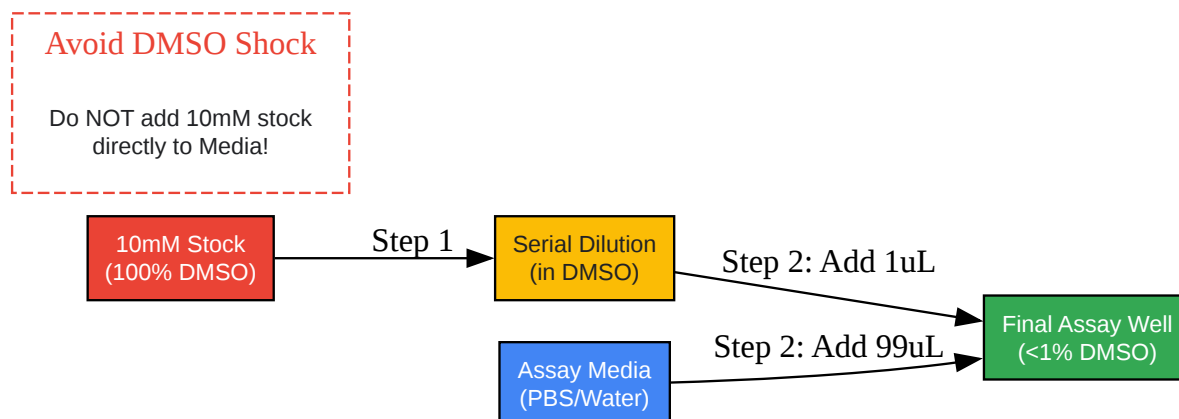

[Click to download full resolution via product page](#)

Figure 2: Serial dilution workflow to prevent precipitation in aqueous buffers.

Frequently Asked Questions (FAQs)

Q1: My compound turned yellow after dissolving in DMSO. Is it degraded?

- A: Likely not. Quinoline derivatives often exhibit solvatochromism. A pale yellow color in DMSO is normal due to the interaction of the solvent with the conjugated -system. However, if it turns dark brown/black, check for oxidation or impurities.

Q2: Can I use Acetone for recrystallization?

- A: Avoid Acetone. Hydrazides () are nucleophilic and can react with ketones (like acetone) to form hydrazones (). This is a common chemical error that destroys your product. Stick to Ethanol or DMF.

Q3: I need to run an NMR, but it crashes out of CDCl₃.

- A: This is expected. Quinoline-3-carbohydrazides are poorly soluble in chloroform.
 - Solution: Use DMSO-d₆. It is the only reliable NMR solvent for this class of compounds.

Q4: How do I remove DMF after purification? It has a high boiling point.

- A: Do not try to rotovap DMF to dryness; you will decompose the product with heat.
 - Method: Pour the DMF solution into excess ice-cold water. The quinoline hydrazide will precipitate.[1][3] Filter it, then wash the solid copiously with water (to remove DMF) and finally with diethyl ether (to dry it).

References

- Synthesis & General Properties
 - El-Sawy, E. R., et al. (2012).
 - Context: Establishes the standard reflux synthesis in ethanol and the precipitation purific
- Solubility in Biological Assays
 - Di, L., & Kerns, E. (2015). Drug-Like Properties: Concepts, Structure Design and Methods.
 - Context: Authoritative text on "DMSO shock" and kinetic solubility protocols for lipophilic drug candid
- Recrystallization of Hydrazides
 - Bhat, M. A., et al. (2023).
 - Context: Confirms solubility in DMSO/DMF and insolubility in diethyl ether; details ethanol recrystalliz
- Chemical Stability (Acetone Warning)
 - Smith, M. B. (2020). March's Advanced Organic Chemistry.
 - Context: Fundamental reactivity of hydrazides with ketones (Schiff base form

Need Custom Synthesis?

BenchChem offers custom synthesis for rare earth carbides and specific isotopic labeling.

Email: info@benchchem.com or [Request Quote Online](#).

Sources

- [1. pdf.benchchem.com \[pdf.benchchem.com\]](https://pdf.benchchem.com)
- [2. pdf.benchchem.com \[pdf.benchchem.com\]](https://pdf.benchchem.com)
- [3. researchgate.net \[researchgate.net\]](https://researchgate.net)
- To cite this document: BenchChem. [Technical Support Center: Solubility & Handling of Quinoline-3-carbohydrazide[1]]. BenchChem, [2026]. [Online PDF]. Available at: [\[https://www.benchchem.com/product/b3073667/docs#technical-support-center-solubility-handling-of-quinoline-3-carbohydrazide-1\]](https://www.benchchem.com/product/b3073667/docs#technical-support-center-solubility-handling-of-quinoline-3-carbohydrazide-1)

Disclaimer & Data Validity:

The information provided in this document is for Research Use Only (RUO) and is strictly not intended for diagnostic or therapeutic procedures. While BenchChem strives to provide accurate protocols, we make no warranties, express or implied, regarding the fitness of this product for every specific experimental setup.

Technical Support: The protocols provided are for reference purposes. Unsure if this reagent suits your experiment?

Need Industrial/Bulk Grade? [Request Custom Synthesis Quote](#)

BenchChem

Our mission is to be the trusted global source of essential and advanced chemicals, empowering scientists and researchers to drive progress in science and industry.

Contact

Address: 3281 E Guasti Rd
Ontario, CA 91761, United States
Phone: (601) 213-4426
Email: info@benchchem.com

Contact our Ph.D. Support Team for a compatibility check