

Mass Spectrometry Fragmentation Patterns of Fluorinated Amines: A Comparative Technical Guide

Author: BenchChem Technical Support Team. **Date:** April 2026

Compound of Interest

Compound Name: 4-(3-fluorophenoxy)butan-1-amine

CAS No.: 1016735-72-0

Cat. No.: B3072408

[Get Quote](#)

Executive Summary

The introduction of fluorine into amine-containing drug candidates profoundly alters mass spectral fragmentation. While non-fluorinated amines follow predictable

-cleavage pathways driven by the nitrogen lone pair, fluorinated analogs exhibit "directed fragmentation" governed by the high electronegativity of fluorine. This guide compares these behaviors across Electron Ionization (EI) and Electrospray Ionization (ESI), providing a robust framework for identifying fluorinated metabolites and impurities.

Mechanistic Comparison: The "Tug-of-War" Effect

The core differentiator in fragmenting fluorinated amines is the electronic competition between the nitrogen lone pair (which drives ionization and radical site initiation) and the fluorine atom (which exerts a strong inductive electron-withdrawing effect,

).

Electron Ionization (EI): Radical-Driven Fragmentation

In EI (70 eV), the molecular ion (

) is a radical cation.

- Non-Fluorinated Amines:

- Dominant Mechanism: [1](#)[2](#) The radical site on nitrogen triggers homolytic cleavage of the C-C bond adjacent to the nitrogen.

-Cleavage. [1](#)[2](#) The radical site on nitrogen triggers homolytic cleavage of the C-C bond adjacent to the nitrogen.

- Result: Formation of a stable iminium ion (

).

- Base Peak: Often

30 (for primary amines) or

58 (for dimethylamines).

- Fluorinated Amines:

- Mechanism Alteration: Fluorine destabilizes the transition state for

-cleavage if the fluorine is attached to the

-carbon or if the resulting carbocation would be electron-deficient.

- The "Steering" Effect: Fragmentation is directed away from the fluorinated group. The molecule prefers to lose the non-fluorinated alkyl chain to maximize cation stability.

- Diagnostic Ions:

- 69 (

): Highly characteristic for trifluoromethyl groups.

- 50 (): Common in perfluorinated chains.

Electrospray Ionization (ESI-MS/MS): Charge-Driven Fragmentation

In ESI, the precursor is typically an even-electron protonated molecule (

).[3]

- Non-Fluorinated Amines:
 - Primary Pathway: Inductive cleavage or loss of ammonia (, -17 Da).
 - Mechanism: Protonation makes N a good leaving group (as neutral amine) or drives charge migration.
- Fluorinated Amines:
 - Dominant Pathway:Hydrogen Fluoride (HF) Elimination.
 - Mechanism: The proton on the nitrogen (or nearby carbon) interacts with the fluorine, leading to the neutral loss of HF (20 Da). This is often the base peak in MS/MS spectra.
 - Significance: A loss of 20 Da is a "smoking gun" for fluorinated amines in metabolite screening.

Comparative Data Analysis

The following table contrasts the expected MS behavior of a standard drug pharmacophore (e.g., an ethylamine side chain) with its fluorinated analogs.

Table 1: Fragmentation Shift Comparison

Feature	Non-Fluorinated Amine (R-CH ₂ -CH ₂ -NH ₂)	-Fluorinated Amine (R-CHF-CH ₂ -NH ₂)	Trifluoromethyl Amine (R-CH(CF ₃)-NH ₂)
Molecular Ion (EI)	Weak	Very Weak / Absent	Absent (Rapid fragmentation)
Base Peak (EI)	30 ()	48 () or 30 (Loss of F-group)	69 () or 30 (if lost)
Major Neutral Loss (ESI)	(17 Da)	HF (20 Da)	(70 Da) or HF (20 Da)
-Cleavage	Dominant	Suppressed / Shifted	Heavily Suppressed (Steric/Electronic)
Diagnostic Marker	Even mass series (30, 44, [1][3][4] 58)	Loss of 20 Da in MS/MS	69 (EI) & Mass Defect

Visualization of Fragmentation Pathways[7][8][9][10]

The following diagram illustrates the divergent pathways for a generic fluorinated amine under ESI-CID conditions, highlighting the characteristic HF elimination.

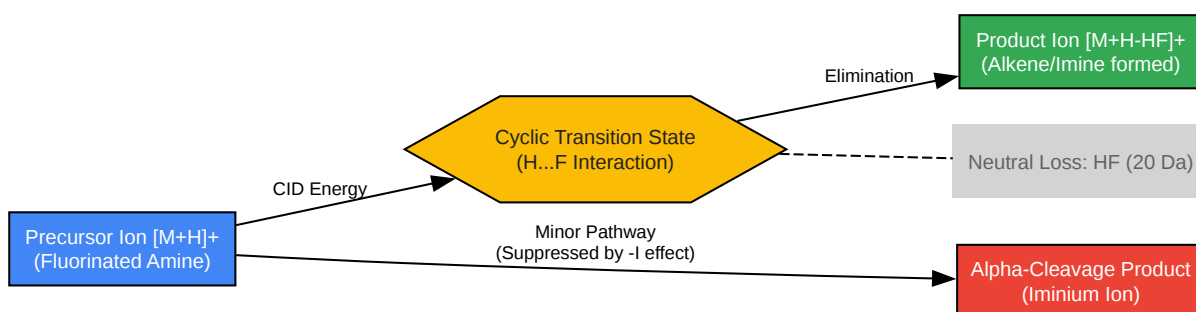

[Click to download full resolution via product page](#)

Figure 1: ESI-MS/MS fragmentation pathway showing the dominance of HF elimination over alpha-cleavage in fluorinated amines.

Experimental Protocol: Validated Identification

Workflow

This protocol is designed for the structural confirmation of a fluorinated amine drug candidate using LC-MS/MS (Q-TOF or Orbitrap).

Objective

To differentiate a fluorinated amine metabolite from non-fluorinated isobaric interferences using characteristic fragmentation.

Materials

- Instrument: High-Resolution Mass Spectrometer (e.g., Q-Exactive or Xevo G2-XS).
- Mobile Phase A: 0.1% Formic Acid in Water.
- Mobile Phase B: 0.1% Formic Acid in Acetonitrile.
- Standard: Fluorinated amine reference standard (1 μ M in 50:50 MeOH:H₂O).

Step-by-Step Workflow

- Source Optimization (Soft vs. Hard):
 - Rationale: Fluorinated amines are labile. High source temperatures can cause in-source HF loss, mimicking a different molecule.
 - Action: Set Source Temp to < 250°C. Set Cone Voltage/S-Lens RF to low values (e.g., 30-40V).
- Full Scan Acquisition (MS1):

- Acquire data in Profile mode.
- Check Mass Defect: Fluorine has a negative mass defect (-0.0016 Da per F atom). A fluorinated compound will have a slightly lower exact mass than a corresponding oxidized metabolite (O replaces H).
- Targeted MS/MS (CID):
 - Apply Stepped Collision Energy (e.g., 20, 35, 50 NCE).
 - Why? HF elimination is a low-energy channel; skeletal rearrangement requires high energy. Stepped CE captures both.
- Data Processing (The "20 Da Rule"):
 - Generate an Extracted Ion Chromatogram (XIC) for the precursor.
 - Examine MS/MS spectra for the neutral loss of 20.0062 Da (HF).
 - Validation: If the loss is 18.0106 Da (

), the compound is likely a hydroxylated metabolite, not a fluorinated analog.
- EI Confirmation (Optional/Orthogonal):
 - If GC-MS is available, derivatize with TFAA (Trifluoroacetic anhydride).
 - Look for the

 69 peak. Note that derivatization adds its own fluorines, so use a non-fluorinated reagent (e.g., MSTFA) if the goal is to detect intrinsic fluorine.

Decision Logic for Identification

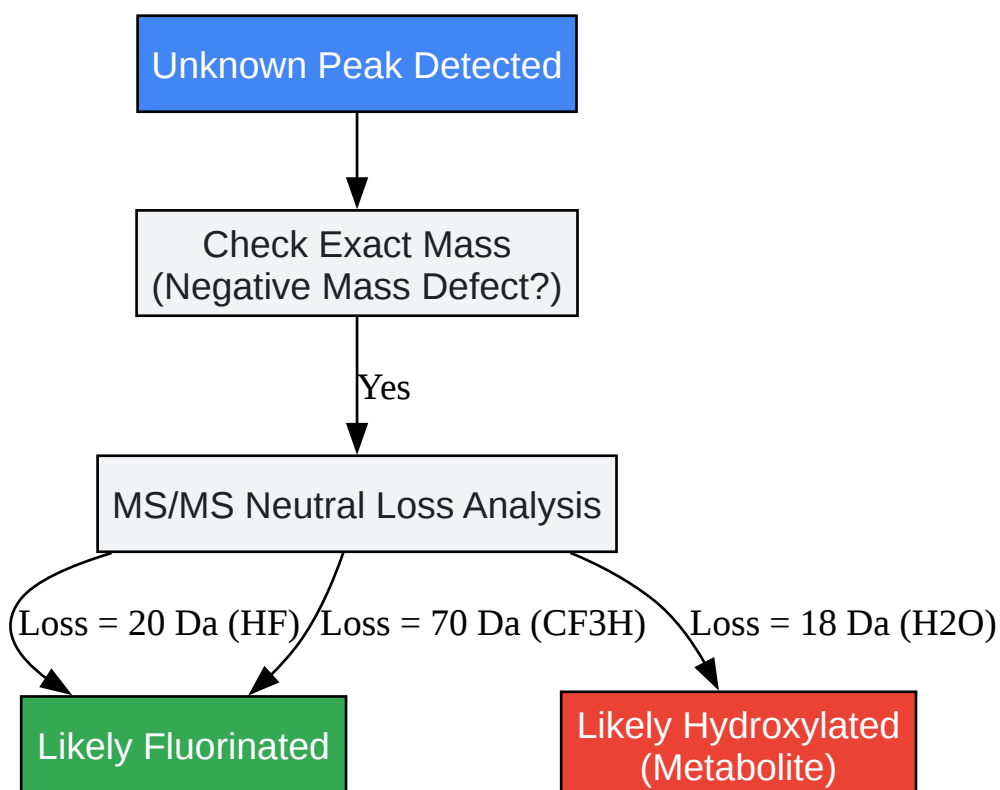

[Click to download full resolution via product page](#)

Figure 2: Logical workflow for distinguishing fluorinated amines from common metabolic interferences.

References

- NIST Mass Spectrometry Data Center. (n.d.). Mass spectra of fluorocarbons. National Institute of Standards and Technology. Retrieved from [\[Link\]](#)
- Chemistry LibreTexts. (2022). Amine Fragmentation. Retrieved from [\[Link\]](#)
- Analytical Chemistry. (2019). High-Sensitivity Elemental Mass Spectrometry of Fluorine by Ionization in Plasma Afterglow. Retrieved from [\[Link\]](#)
- ResearchGate. (2020). Electron ionization induced fragmentation of fluorinated derivatives of bisphenols. Retrieved from [\[Link\]](#)

Need Custom Synthesis?

BenchChem offers custom synthesis for rare earth carbides and specific isotopic labeling.

Email: info@benchchem.com or [Request Quote Online](#).

Sources

- [1. chem.libretexts.org \[chem.libretexts.org\]](https://chem.libretexts.org)
- [2. Alpha cleavage - Wikipedia \[en.wikipedia.org\]](https://en.wikipedia.org)
- [3. peptid.chem.elte.hu \[peptid.chem.elte.hu\]](https://peptid.chem.elte.hu)
- [4. uni-saarland.de \[uni-saarland.de\]](https://uni-saarland.de)
- To cite this document: BenchChem. [Mass Spectrometry Fragmentation Patterns of Fluorinated Amines: A Comparative Technical Guide]. BenchChem, [2026]. [Online PDF]. Available at: [<https://www.benchchem.com/product/b3072408/docs#mass-spectrometry-fragmentation-patterns-of-fluorinated-amines-a-comparative-technical-guide>]

Disclaimer & Data Validity:

The information provided in this document is for Research Use Only (RUO) and is strictly not intended for diagnostic or therapeutic procedures. While BenchChem strives to provide accurate protocols, we make no warranties, express or implied, regarding the fitness of this product for every specific experimental setup.

Technical Support: The protocols provided are for reference purposes. Unsure if this reagent suits your experiment?

Need Industrial/Bulk Grade? [Request Custom Synthesis Quote](#)

BenchChem

Our mission is to be the trusted global source of essential and advanced chemicals, empowering scientists and researchers to drive progress in science and industry.

Contact

Address: 3281 E Guasti Rd

Ontario, CA 91761, United States

Phone: (601) 213-4426

Email: info@benchchem.com

[Contact our Ph.D. Support Team for a compatibility check](#)