

The Synthesis and Pivotal Role of 2-Iodothiophenol in Drug Discovery

Author: BenchChem Technical Support Team. **Date:** December 2025

Compound of Interest

Compound Name: 2-Iodothiophenol

Cat. No.: B3069315

[Get Quote](#)

An In-depth Technical Guide for Researchers, Scientists, and Drug Development Professionals

Abstract

2-Iodothiophenol, a seemingly unassuming organoiodine compound, holds a significant position in the landscape of modern organic synthesis and medicinal chemistry. Its unique bifunctional nature, possessing both a reactive thiol group and an iodine-substituted aromatic ring, renders it a versatile building block for the construction of complex heterocyclic scaffolds. This technical guide provides a comprehensive overview of the synthesis, discovery, and applications of **2-iodothiophenol**, with a particular focus on its crucial role as a precursor to therapeutically active molecules. Detailed experimental protocols for its preparation are presented, alongside a quantitative analysis of reaction parameters. Furthermore, this guide delves into the utility of **2-iodothiophenol** in the synthesis of benzothiazole derivatives, culminating in an examination of their engagement with key signaling pathways relevant to cancer and metabolic diseases.

Introduction: The Emergence of a Versatile Synthetic Intermediate

The strategic importance of halogenated thiophenols in organic synthesis cannot be overstated. The presence of both a nucleophilic thiol group and a carbon-halogen bond susceptible to a myriad of cross-coupling reactions provides a powerful handle for molecular elaboration. Among these, **2-iodothiophenol** (also known as 2-iodobenzenethiol) has emerged

as a particularly valuable synthon. Its journey from a laboratory curiosity to a key component in the drug discovery pipeline is a testament to its synthetic utility. While the exact first synthesis is not prominently documented in readily available literature, its use in the early 20th century can be inferred from the broader development of aromatic iodine chemistry. The true value of **2-iodothiophenol** was unlocked with the advent of modern transition-metal-catalyzed cross-coupling reactions, which provided efficient methods for the formation of carbon-carbon and carbon-heteroatom bonds at the iodo-substituted position.

Synthesis of 2-Iodothiophenol: Core Methodologies

The preparation of **2-iodothiophenol** is primarily achieved through two well-established synthetic routes: the Sandmeyer reaction of 2-aminothiophenol and the direct iodination of thiophenol. The choice of method often depends on the availability of starting materials and the desired scale of the reaction.

Synthesis via Diazotization-Iodination of 2-Aminothiophenol (Sandmeyer Reaction)

This classical approach involves the conversion of the amino group of 2-aminothiophenol into a diazonium salt, which is subsequently displaced by an iodide ion. This method is generally reliable and provides good yields of the desired product.

Materials:

- 2-Aminothiophenol
- Concentrated Hydrochloric Acid (HCl)
- Sodium Nitrite (NaNO_2)
- Potassium Iodide (KI)
- Diethyl Ether
- Saturated Sodium Bicarbonate Solution
- Brine

- Anhydrous Magnesium Sulfate (MgSO_4)

Procedure:

- In a three-necked round-bottom flask equipped with a mechanical stirrer, a dropping funnel, and a thermometer, a solution of 2-aminothiophenol (1.0 eq) in concentrated hydrochloric acid (3.0 eq) and water is prepared and cooled to 0-5 °C in an ice-salt bath.
- A solution of sodium nitrite (1.1 eq) in water is added dropwise to the stirred solution, maintaining the temperature below 5 °C. The reaction mixture is stirred for an additional 30 minutes at this temperature to ensure complete diazotization.
- A solution of potassium iodide (1.5 eq) in water is then added portion-wise to the cold diazonium salt solution. Effervescence (evolution of nitrogen gas) is observed.
- After the addition is complete, the reaction mixture is allowed to warm to room temperature and stirred for 1-2 hours.
- The reaction mixture is then transferred to a separatory funnel and extracted with diethyl ether (3 x 50 mL).
- The combined organic layers are washed with saturated sodium bicarbonate solution, water, and brine.
- The organic layer is dried over anhydrous magnesium sulfate, filtered, and the solvent is removed under reduced pressure to afford the crude **2-iodothiophenol**.
- The crude product can be purified by vacuum distillation or column chromatography on silica gel.

Logical Workflow for the Sandmeyer Synthesis of **2-Iodothiophenol**

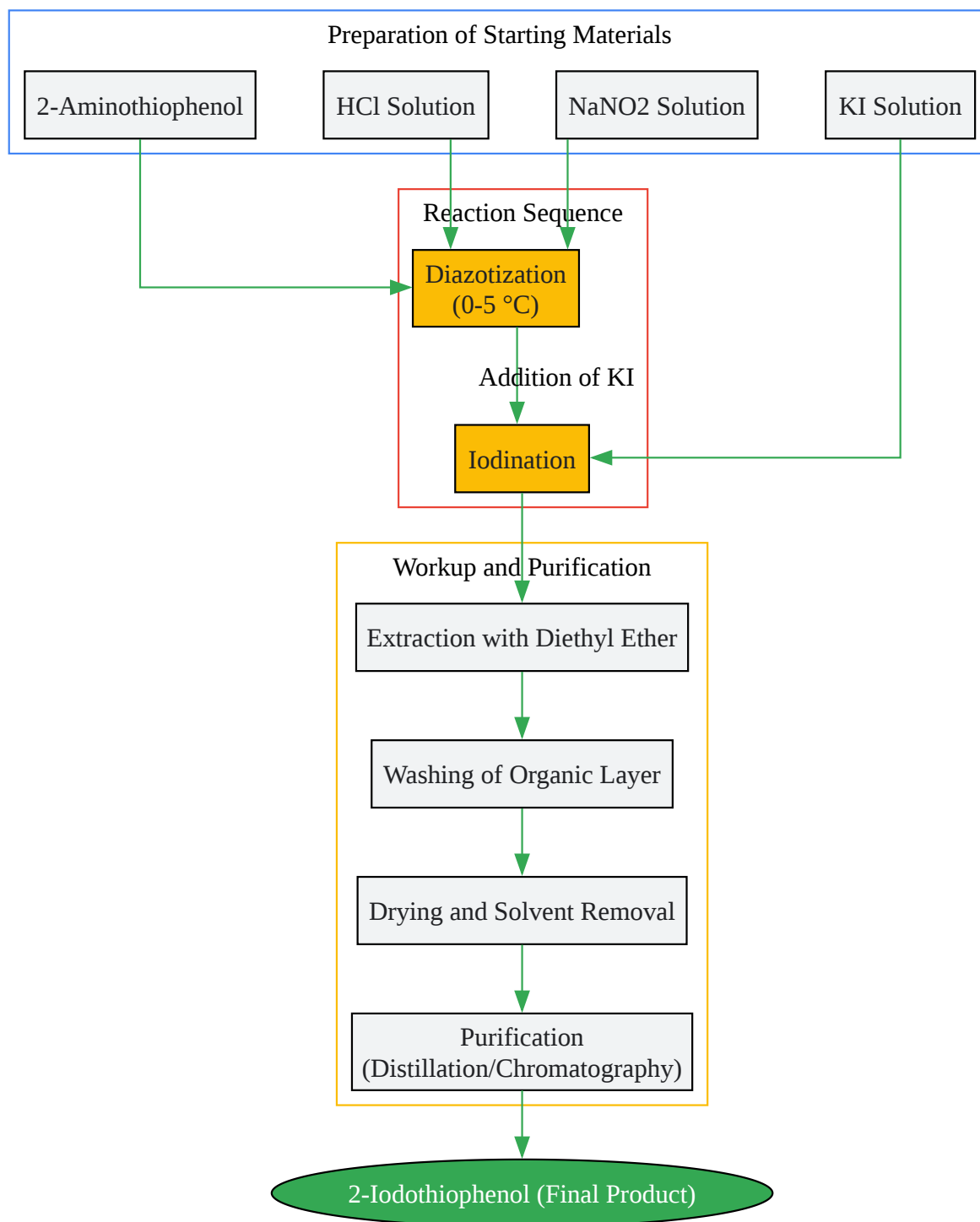

[Click to download full resolution via product page](#)

Caption: Workflow for the synthesis of **2-Iodothiophenol** via the Sandmeyer reaction.

Direct Iodination of Thiophenol

This method involves the electrophilic substitution of a hydrogen atom on the thiophenol ring with an iodine atom. The reaction is typically carried out in the presence of an iodinating agent and a base or an acid catalyst. The ortho-para directing nature of the thiol group can lead to a mixture of isomers, making purification a critical step.

Materials:

- Thiophenol
- Iodine (I₂)
- Potassium Iodide (KI) (optional, to form I₃⁻)
- A suitable solvent (e.g., ethanol, acetic acid)
- A base (e.g., sodium hydroxide) or an acid catalyst
- Sodium Thiosulfate Solution
- Dichloromethane
- Brine
- Anhydrous Sodium Sulfate (Na₂SO₄)

Procedure:

- Thiophenol (1.0 eq) is dissolved in a suitable solvent in a round-bottom flask.
- A solution of iodine (1.0-1.2 eq) and optionally potassium iodide in the same solvent is added dropwise to the thiophenol solution at room temperature.
- A base or an acid catalyst is added to the reaction mixture. The reaction is stirred at room temperature or with gentle heating for several hours until completion (monitored by TLC).
- Upon completion, the reaction is quenched by the addition of a sodium thiosulfate solution to remove any unreacted iodine.

- The mixture is extracted with dichloromethane (3 x 50 mL).
- The combined organic layers are washed with water and brine.
- The organic layer is dried over anhydrous sodium sulfate, filtered, and the solvent is evaporated under reduced pressure.
- The resulting crude product, which may contain a mixture of isomers, is purified by column chromatography on silica gel to isolate the **2-iodothiophenol**.

Quantitative Data and Characterization

The yield and purity of **2-iodothiophenol** are highly dependent on the chosen synthetic route and the optimization of reaction conditions.

Parameter	Sandmeyer Reaction	Direct Iodination
Typical Yield	60-80%	40-60%
Purity (Post-Purification)	>98%	>95%
Key Reaction Conditions	Low Temperature (0-5°C)	Catalyst Dependent
Major Byproducts	Diazonium salt decomposition products	4-Iodothiophenol

Spectroscopic Data for **2-Iodothiophenol**:

- ^1H NMR (CDCl_3 , ppm): δ 7.78 (dd, 1H), 7.25 (td, 1H), 6.95 (dd, 1H), 6.75 (td, 1H), 3.65 (s, 1H, SH).
- ^{13}C NMR (CDCl_3 , ppm): δ 139.5, 133.2, 129.5, 128.8, 125.1, 100.2.
- IR (KBr, cm^{-1}): ν 3050 (Ar-H), 2550 (S-H), 1570, 1450 (C=C).
- Mass Spectrometry (EI): m/z 236 (M^+).

Role in Drug Discovery: A Gateway to Bioactive Benzothiazoles

2-Iodothiophenol is a cornerstone in the synthesis of benzothiazoles, a class of heterocyclic compounds with a remarkable spectrum of biological activities. The fusion of a benzene ring and a thiazole ring creates a scaffold that can interact with a variety of biological targets.

Synthesis of Benzothiazole Derivatives

A common and efficient method for the synthesis of 2-substituted benzothiazoles from **2-iodothiophenol** involves a palladium-catalyzed Sonogashira coupling with a terminal alkyne, followed by an intramolecular cyclization.

Reactant 1	Reactant 2	Catalyst/Reagents	Product Class	Reported Yield
2-Iodothiophenol	Terminal Alkyne	Pd(OAc) ₂ , Ligand (e.g., PPh ₃), CuI, Base (e.g., Et ₃ N)	2-Substituted Benzothiazoles	Up to 87% ^[1]
2-Iodothiophenol	Ammonia	Copper(I) Iodide	2- Aminothiophenol	~65% ^[2]
2-Iodothiophenol	Hydrogen Peroxide	-	Bis(2- iodophenyl) disulfide	Up to 92% ^[2]

Benzothiazoles as Anticancer Agents

Numerous benzothiazole derivatives have demonstrated potent anticancer activity through various mechanisms of action. These include:

- **Inhibition of Cytochrome P450 Enzymes:** Certain fluorinated 2-(4-aminophenyl)benzothiazoles have shown potent and selective cytotoxicity against breast cancer cell lines by inhibiting CYP1A1.

- **Disruption of the Thioredoxin Signaling System:** This system is crucial for maintaining cellular redox balance and is often upregulated in cancer cells. Benzothiazole derivatives can inhibit thioredoxin reductase, leading to increased oxidative stress and apoptosis in cancer cells.
- **Topoisomerase Inhibition:** Topoisomerases are essential enzymes for DNA replication and repair. Some benzothiazole-based compounds can inhibit these enzymes, leading to DNA damage and cell death.
- **Kinase Inhibition:** Benzothiazoles can act as inhibitors of various protein kinases, such as EGFR and VEGFR, which are key components of signaling pathways that drive cancer cell proliferation and survival.^{[3][4]}

Anticancer Mechanisms of Benzothiazole Derivatives

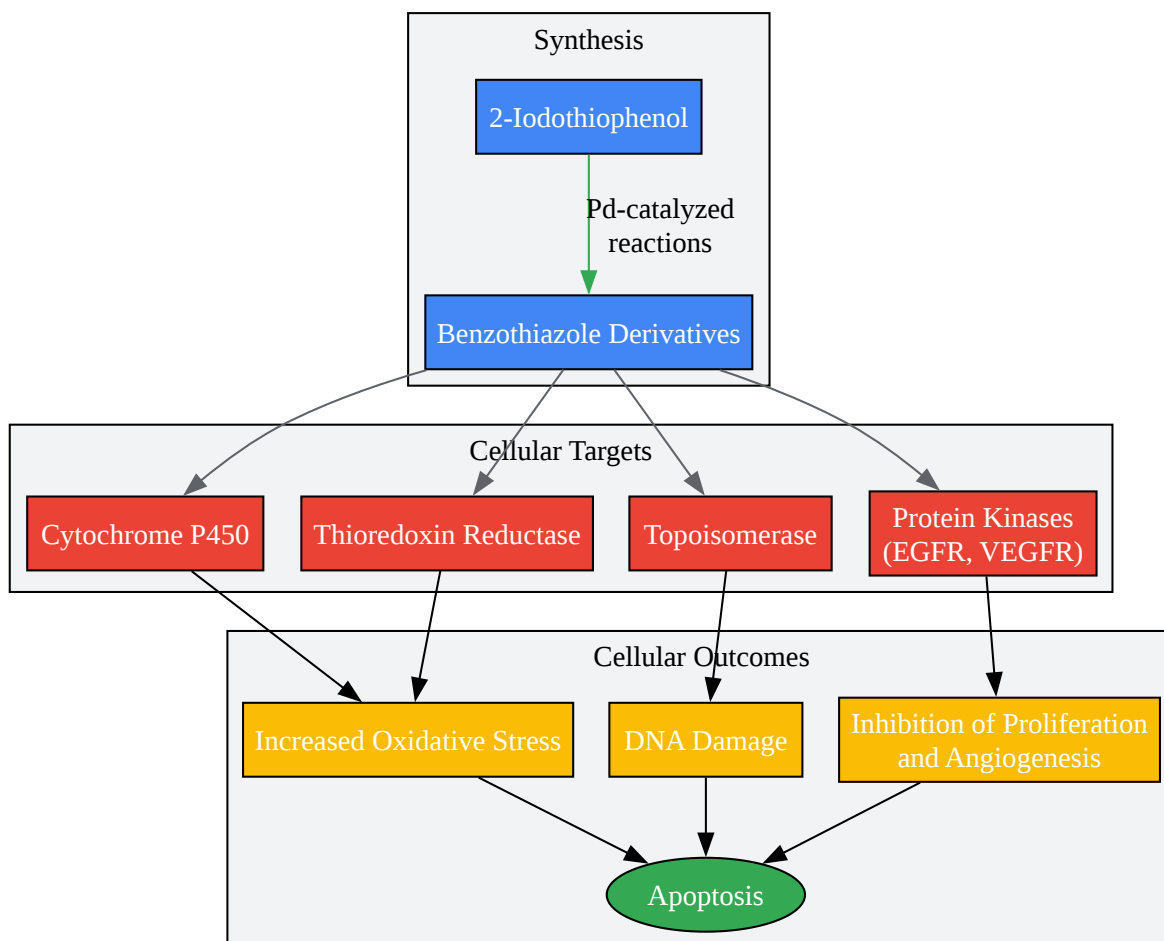

[Click to download full resolution via product page](#)

Caption: Key cellular targets and outcomes of anticancer benzothiazole derivatives.

Benzothiazoles in Metabolic Diseases: Targeting the AMPK Signaling Pathway

Recent research has highlighted the potential of benzothiazole derivatives in the treatment of metabolic diseases, particularly type 2 diabetes. Certain benzothiazoles have been shown to

activate AMP-activated protein kinase (AMPK), a central regulator of cellular energy homeostasis.[3][5]

The AMPK Signaling Pathway:

AMPK is a serine/threonine kinase that acts as a cellular energy sensor. When the cellular AMP:ATP ratio increases, indicating low energy status, AMPK is activated. Activated AMPK then phosphorylates a variety of downstream targets to restore energy balance by:

- Stimulating catabolic pathways that generate ATP, such as glucose uptake and fatty acid oxidation.
- Inhibiting anabolic pathways that consume ATP, such as protein and lipid synthesis.

Benzothiazole derivatives that activate AMPK can therefore mimic the effects of cellular energy stress, leading to beneficial metabolic outcomes such as increased glucose uptake in muscle cells and enhanced insulin sensitivity.[3]

Activation of the AMPK Signaling Pathway by Benzothiazole Derivatives

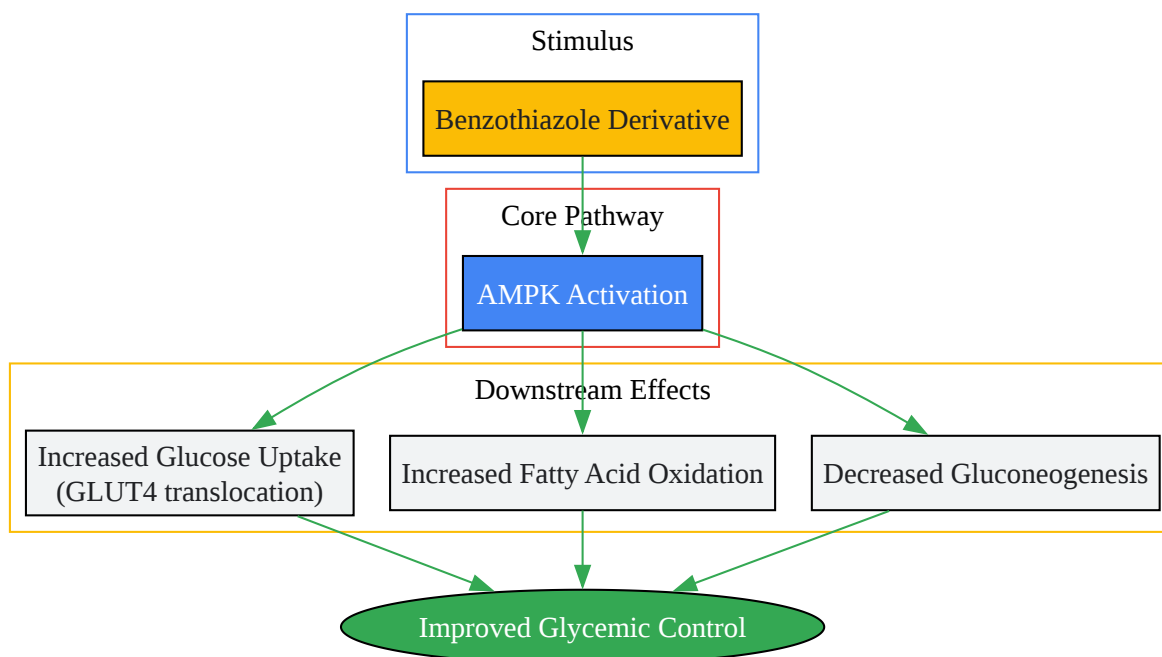

[Click to download full resolution via product page](#)

Caption: Simplified schematic of AMPK pathway activation by benzothiazole derivatives.

Conclusion and Future Perspectives

2-Iodothiophenol has firmly established itself as a versatile and indispensable building block in organic synthesis, particularly for the construction of biologically active heterocyclic compounds. The synthetic routes to **2-iodothiophenol** are robust and well-characterized, providing a reliable supply of this key intermediate. Its application in the synthesis of benzothiazole derivatives has yielded a wealth of compounds with promising therapeutic potential, particularly in the fields of oncology and metabolic diseases.

The future of **2-iodothiophenol** chemistry lies in the development of even more efficient and sustainable synthetic methodologies, including the exploration of novel catalytic systems for its derivatization. Furthermore, the continued exploration of the biological activities of benzothiazoles and other heterocycles derived from **2-iodothiophenol** is expected to uncover new therapeutic targets and lead to the development of next-generation drugs for a range of

human diseases. The ability to rationally design and synthesize novel benzothiazole-based molecules, empowered by a deep understanding of their structure-activity relationships and mechanisms of action, will undoubtedly continue to be a vibrant and fruitful area of research for years to come.

Need Custom Synthesis?

BenchChem offers custom synthesis for rare earth carbides and specific isotopic labeling.

Email: info@benchchem.com or [Request Quote Online](#).

References

- 1. 2-Iodothiophenol | C₆H₅IS | CID 10955536 - PubChem [pubchem.ncbi.nlm.nih.gov]
- 2. Synthesis of 2-Substituted Benzothiazole Derivatives and Their In Vitro Anticancer Effects and Antioxidant Activities Against Pancreatic Cancer Cells | Anticancer Research [ar.iiarjournals.org]
- 3. Benzothiazole derivatives augment glucose uptake in skeletal muscle cells and stimulate insulin secretion from pancreatic β -cells via AMPK activation - PubMed [pubmed.ncbi.nlm.nih.gov]
- 4. Benzothiazole derivatives as anticancer agents - PMC [pmc.ncbi.nlm.nih.gov]
- 5. [researchgate.net](https://www.researchgate.net) [[researchgate.net](https://www.researchgate.net)]
- To cite this document: BenchChem. [The Synthesis and Pivotal Role of 2-Iodothiophenol in Drug Discovery]. BenchChem, [2025]. [Online PDF]. Available at: [<https://www.benchchem.com/product/b3069315#synthesis-and-discovery-of-2-iodothiophenol>]

Disclaimer & Data Validity:

The information provided in this document is for Research Use Only (RUO) and is strictly not intended for diagnostic or therapeutic procedures. While BenchChem strives to provide accurate protocols, we make no warranties, express or implied, regarding the fitness of this product for every specific experimental setup.

Technical Support: The protocols provided are for reference purposes. Unsure if this reagent suits your experiment? [[Contact our Ph.D. Support Team for a compatibility check](#)]

Need Industrial/Bulk Grade? [Request Custom Synthesis Quote](#)

BenchChem

Our mission is to be the trusted global source of essential and advanced chemicals, empowering scientists and researchers to drive progress in science and industry.

Contact

Address: 3281 E Guasti Rd

Ontario, CA 91761, United States

Phone: (601) 213-4426

Email: info@benchchem.com