

# Spectroscopic data for 2-Methyl-5-phenylpentan-2-ol characterization

**Author:** BenchChem Technical Support Team. **Date:** April 2026

## Compound of Interest

Compound Name: 2-Methyl-5-phenylpentan-2-ol

CAS No.: 2979-70-6

Cat. No.: B3060360

[Get Quote](#)

An In-Depth Technical Guide to the Spectroscopic Characterization of **2-Methyl-5-phenylpentan-2-ol**

## Executive Summary

**2-Methyl-5-phenylpentan-2-ol** (CAS: 2979-70-6) is a tertiary alcohol featuring a phenyl-terminated alkyl chain. Often utilized as a lipophilic building block in the synthesis of fragrances (e.g., Rosaphen derivatives) and pharmaceutical intermediates (e.g., retinoid antagonists), its characterization relies on distinguishing the tertiary hydroxyl center from the aromatic tail.

This guide provides a definitive spectroscopic profile, integrating Nuclear Magnetic Resonance (NMR), Infrared Spectroscopy (IR), and Mass Spectrometry (MS) data.<sup>[1]</sup> The protocols described herein are designed to validate structural identity and purity in drug development and fine chemical manufacturing.

## Structural Analysis & Synthetic Origin

Understanding the synthesis is crucial for anticipating impurities. The standard industrial route involves a Grignard reaction, which dictates the likely contaminants (e.g., homocoupling

products or unreacted ketone).

**Synthesis Pathway:** The compound is synthesized via the nucleophilic addition of the Grignard reagent derived from 1-bromo-3-phenylpropane to acetone.

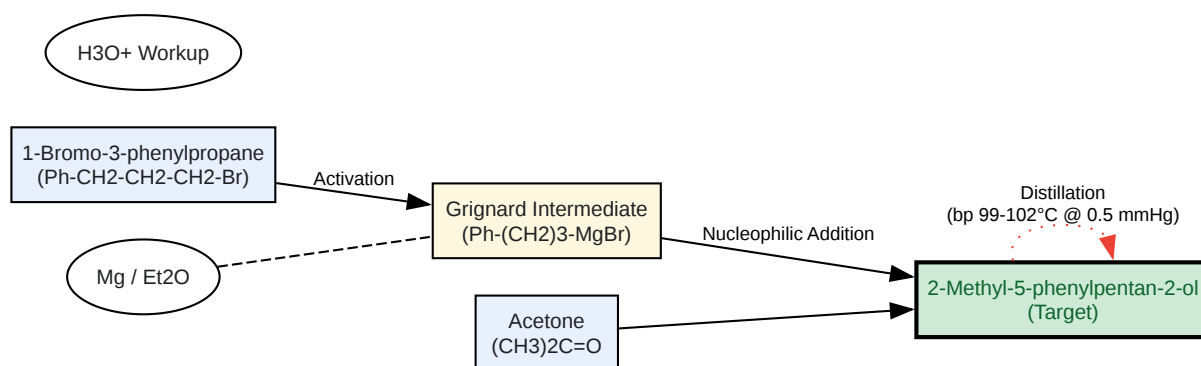

[Click to download full resolution via product page](#)

Figure 1: Synthetic pathway for **2-Methyl-5-phenylpentan-2-ol** via Grignard addition.

## Spectroscopic Characterization

### Nuclear Magnetic Resonance (NMR) Spectroscopy

NMR is the primary tool for structural validation. The molecule possesses a

local symmetry at the isopropyl terminus (free rotation makes the methyls equivalent) and a distinct aromatic region.

Sample Preparation:

- Solvent: Chloroform-d ( , 99.8% D) with 0.03% TMS.
- Concentration: ~15 mg in 0.6 mL solvent.
- Reference: TMS at 0.00 ppm (

) and 77.16 ppm (

).

Table 1:

NMR Data (300 MHz,

)

Chemical Shift ( , ppm)	Multiplicity	Integration	Assignment	Structural Context
7.26 – 7.07	Multiplet (m)	5H	Ar-H	Phenyl ring protons (Ortho/Meta/Para overlap).
2.54	Triplet (t, Hz)	2H	Ph-CH -	Benzylic protons (C5). Deshielded by ring current.
1.70 – 1.54	Multiplet (m)	2H	-CH -	C4 Methylene (Middle of chain).
1.49 – 1.37	Multiplet (m)	2H	-CH -C(OH)	C3 Methylene (to Hydroxyl).
1.12	Singlet (s)	6H	-C(CH) ) OH	Gem-dimethyl protons. Sharp singlet confirms tertiary nature.
1.30 – 1.60	Broad Singlet	1H	-OH	Hydroxyl proton (Concentration dependent).

> Note: Literature values vary slightly based on concentration. The methyl singlet is reported at 1.20 ppm in older patent literature but consistently appears near 1.12–1.20 ppm.

Table 2:

NMR Data (75 MHz,

)

Chemical Shift ( , ppm)	Carbon Type	Assignment	Structural Context
142.3	Quaternary (C)	Ar-C	Phenyl attachment point.
128.5	Methine (CH)	Ar-C	Aromatic ring.
128.4	Methine (CH)	Ar-C	Aromatic ring.
125.8	Methine (CH)	Ar-C	Aromatic ring.
71.1	Quaternary (C)	C-OH	Carbinol carbon. Characteristic of tertiary alcohols.
43.6	Methylene (CH )	-CH -C(OH)	C3 (Beta to alcohol).
36.0	Methylene (CH )	Ph-CH -	C5 (Benzylic).
29.4	Methyl (CH )	-C(CH )	Gem-dimethyl carbons.
26.5	Methylene (CH )	-CH -	C4 (Gamma to alcohol).

## Infrared Spectroscopy (FT-IR)

IR analysis is used primarily to confirm the presence of the hydroxyl group and the absence of carbonyl impurities (from unreacted acetone).

Key Absorption Bands (Neat Film/ATR):

- 3350–3450 cm

(Broad): O-H stretching vibration (Intermolecular H-bonding).

- 3020–3080 cm

(Weak): Aromatic C-H stretching (

).

- 2960, 2925, 2855 cm

(Strong): Aliphatic C-H stretching (

).

- 1600, 1495, 1450 cm

: Aromatic ring skeletal vibrations (C=C).

- 1150 cm

: C-O stretching (Tertiary alcohol).

- 700, 750 cm

: C-H out-of-plane bending (Monosubstituted benzene).

## Mass Spectrometry (MS)

For tertiary alcohols, the molecular ion (

) is often weak or absent due to facile dehydration or

-cleavage.

Ionization Mode: Electron Impact (EI, 70 eV)[1]

- Molecular Ion ( ): m/z 178 (Trace/Weak).
- Base Peak: m/z 91 (Tropylium ion, ) or m/z 59.
- Key Fragments:
  - m/z 163 ( ): Loss of methyl group.
  - m/z 160 ( ): Loss of water (Dehydration).
  - m/z 59 ( ):  
-cleavage generating the 2-hydroxy-2-propyl cation ( ). This is diagnostic for the 2-methyl-2-hydroxy terminus.[2]

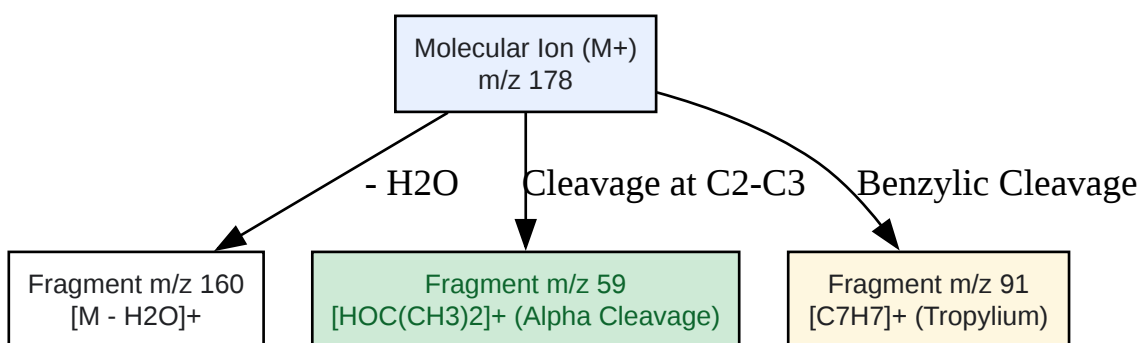

[Click to download full resolution via product page](#)

Figure 2: Primary fragmentation pathways in Electron Impact Mass Spectrometry.

## Experimental Protocol: Purity Assessment

To ensure the material meets pharmaceutical standards (>98% purity), the following HPLC method is recommended.

Method: Reverse-Phase HPLC

- Column: C18 (e.g., Agilent Zorbax Eclipse Plus, 4.6 x 100 mm, 3.5  $\mu$ m).
- Mobile Phase:
  - A: Water + 0.1% Phosphoric Acid.
  - B: Acetonitrile.
- Gradient: 50% B to 90% B over 10 minutes.
- Flow Rate: 1.0 mL/min.
- Detection: UV at 210 nm (Ar ring absorption) and 254 nm.
- Retention Time: The tertiary alcohol will elute before the non-polar starting material (1-bromo-3-phenylpropane) but after simpler benzylic alcohols due to the lipophilic pentyl chain.

## References

- Royal Society of Chemistry (RSC).

NMR data for **2-methyl-5-phenylpentan-2-ol**.

- United States Patent 5,958,954. Synthesis and use of retinoid compounds having negative hormone and/or antagonist activities. (Details the Grignard synthesis and bulk characterization).
- American Chemical Society (ACS). Synthesis of Ethers via Reaction of Carbanions and Monoperoxyacetals. (Contains characterization of related ether derivatives and confirming spectral data).

### Need Custom Synthesis?

BenchChem offers custom synthesis for rare earth carbides and specific isotopic labeling.

Email: [info@benchchem.com](mailto:info@benchchem.com) or [Request Quote Online](#).

## Sources

- 1. [pdf.benchchem.com](https://pdf.benchchem.com) [[pdf.benchchem.com](https://pdf.benchchem.com)]
- 2. 2-Hydroxy-2-methyl-5-phenylpentane | C<sub>12</sub>H<sub>18</sub>O | CID 346429 - PubChem [[pubchem.ncbi.nlm.nih.gov](https://pubchem.ncbi.nlm.nih.gov)]
- To cite this document: BenchChem. [Spectroscopic data for 2-Methyl-5-phenylpentan-2-ol characterization]. BenchChem, [2026]. [Online PDF]. Available at: [<https://www.benchchem.com/product/b3060360/docs#spectroscopic-data-for-2-methyl-5-phenylpentan-2-ol-characterization>]

### Disclaimer & Data Validity:

The information provided in this document is for Research Use Only (RUO) and is strictly not intended for diagnostic or therapeutic procedures. While BenchChem strives to provide accurate protocols, we make no warranties, express or implied, regarding the fitness of this product for every specific experimental setup.

**Technical Support:** The protocols provided are for reference purposes. Unsure if this reagent suits your experiment?

**Need Industrial/Bulk Grade?** [Request Custom Synthesis Quote](#)

## BenchChem

Our mission is to be the trusted global source of essential and advanced chemicals, empowering scientists and researchers to drive progress in science and industry.

### Contact

Address: 3281 E Guasti Rd  
Ontario, CA 91761, United States  
Phone: (601) 213-4426  
Email: [info@benchchem.com](mailto:info@benchchem.com)

Contact our Ph.D. Support Team for a compatibility check