

Application Note: Process Development & Scale-Up of 6-Isopropyl-7-methoxy-1-tetralone

Author: BenchChem Technical Support Team. **Date:** April 2026

Compound of Interest

Compound Name: 6-Isopropyl-7-methoxy-1-tetralone

CAS No.: 22009-41-2

Cat. No.: B3060310

[Get Quote](#)

Abstract & Strategic Overview

6-Isopropyl-7-methoxy-1-tetralone is a critical bicyclic intermediate employed in the synthesis of bioactive diterpenes (e.g., miltirone, carnosic acid analogs) and specific GPCR ligands. While direct alkylation of 7-methoxy-1-tetralone is theoretically possible, it suffers from poor regioselectivity (yielding 5-, 6-, and 8-isomers) and poly-alkylation, making it unsuitable for GMP or GLP scale-up where impurity profiles must be strictly controlled.

This Application Note details a robust, linearly scalable 3-step synthesis starting from 2-isopropylphenol (o-cumenol). This route is selected for its defined regiochemistry, utilizing the steric bulk of the isopropyl group to direct ring closure, thereby guaranteeing the 6,7-substitution pattern.

Key Process Advantages

- **Regiocontrol:** Stepwise construction eliminates positional isomers common in direct Friedel-Crafts alkylation.

- Scalability: Avoids hazardous reagents like mercury (Clemmensen) or hydrazine (Wolff-Kishner) in favor of catalytic hydrogenation.
- Purification: Designed to rely on crystallization rather than large-scale chromatography.

Retrosynthetic Analysis & Pathway

The synthesis relies on a classical Friedel-Crafts acylation followed by ring closure. The critical design choice is the starting material: 2-isopropylanisole.

Reaction Scheme (Graphviz)



[Click to download full resolution via product page](#)

Figure 1: Synthetic pathway designed for high regiochemical fidelity.

Detailed Experimental Protocols

Pre-Step: Preparation of 2-Isopropylanisole

Note: If not purchased commercially, synthesize from 2-isopropylphenol.

- Dissolve 2-isopropylphenol (1.0 eq) in Acetone.
- Add K₂CO₃ (1.5 eq) and Methyl Iodide (1.2 eq).
- Reflux for 4–6 hours. Filter salts, concentrate, and distill.[1][2]
- QC Check: GC-MS >98% purity.

Step 1: Friedel-Crafts Succinoylation

Objective: Introduce the four-carbon chain. Mechanism: The methoxy group (strong activator) directs the incoming succinyl group para to itself (Position 4), overriding the ortho/para direction of the isopropyl group due to steric hindrance at Position 6.

Parameter	Specification
Reagents	2-Isopropylanisole (1.0 eq), Succinic Anhydride (1.2 eq), AlCl ₃ (2.5 eq)
Solvent	Dichloromethane (DCM) or 1,2-Dichloroethane (DCE)
Temperature	Addition at 0–5°C; Reaction at RT (25°C)
Time	4–6 Hours

Protocol:

- Charge a reactor with AlCl₃ (2.5 eq) and DCM (5 vol). Cool to 0°C.[3]
- Add Succinic Anhydride (1.2 eq) portion-wise. Stir for 30 min to form the acylium complex.
- Add 2-Isopropylanisole (1.0 eq) diluted in DCM (2 vol) dropwise over 1 hour. Caution: Exothermic.
- Warm to room temperature and stir until HPLC indicates <1% starting material.
- Quench: Pour mixture slowly into ice/HCl (conc). Caution: HCl gas evolution.
- Workup: Separate organic phase. Extract aqueous with DCM. Wash combined organics with brine.
- Isolation: Extract the organic phase with 10% NaOH (aq). The product (acid) moves to the aqueous phase.
- Acidify the aqueous phase with HCl to pH 1. The keto-acid precipitates. Filter and dry.[1][2]
 - Product: 4-(3-isopropyl-4-methoxyphenyl)-4-oxobutanoic acid.

Step 2: Carbonyl Reduction (Catalytic Hydrogenation)

Objective: Reduce the benzylic ketone to a methylene group. Scale-Up Note: Catalytic hydrogenation is preferred over Wolff-Kishner (hydrazine toxicity) or Clemmensen (Mercury waste) for safety and environmental compliance.

Parameter	Specification
Catalyst	10% Pd/C (5-10 wt% loading)
Solvent	Acetic Acid (glacial) with catalytic HClO ₄ or H ₂ SO ₄
Pressure	3–5 bar H ₂
Temperature	60–70°C

Protocol:

- Dissolve the Keto-Acid from Step 1 in Glacial Acetic Acid (10 vol).
- Add catalytic H₂SO₄ (0.1 eq) to promote complete reduction of the alcohol intermediate.
- Charge Pd/C catalyst under inert atmosphere (N₂).
- Pressurize with Hydrogen (5 bar) and heat to 65°C.
- Monitor H₂ uptake. Reaction is complete when uptake ceases and HPLC confirms absence of ketone/alcohol intermediates.
- Workup: Filter catalyst (hot filtration recommended). Pour filtrate into water.
- Isolation: The product precipitates. Filter, wash with water, and dry.
 - Product: 4-(3-isopropyl-4-methoxyphenyl)butanoic acid.

Step 3: Intramolecular Cyclization

Objective: Ring closure to form the tetralone. Mechanism: The acid chloride (generated in situ or using strong acid) attacks the ring. Regioselectivity: The ring closes at the position para to the Isopropyl group. The position ortho to the Methoxy group is sterically blocked by the alkyl chain, and the position meta to Methoxy is generally deactivated, but the para-alkyl activation allows closure at the sterically free position.

Parameter	Specification
Reagent	Methanesulfonic Acid (MSA) or Polyphosphoric Acid (PPA)
Preference	MSA (easier stirring/quenching than PPA)
Temperature	70–80°C
Time	2–4 Hours

Protocol:

- Charge MSA (5–8 vol) to the reactor. Heat to 70°C.
- Add the Arylbutyric Acid from Step 2 portion-wise.
- Stir until HPLC shows conversion. (Note: Prolonged heating may cause demethylation).
- Quench: Cool to 20°C. Pour onto crushed ice/water.
- Extraction: Extract with Ethyl Acetate or MTBE.
- Purification: Wash organics with NaHCO₃ (sat), then Brine. Dry and concentrate.
- Crystallization: Recrystallize from Hexane/Ethyl Acetate (9:1) to remove trace regioisomers.

Process Engineering & Safety (Graphviz)

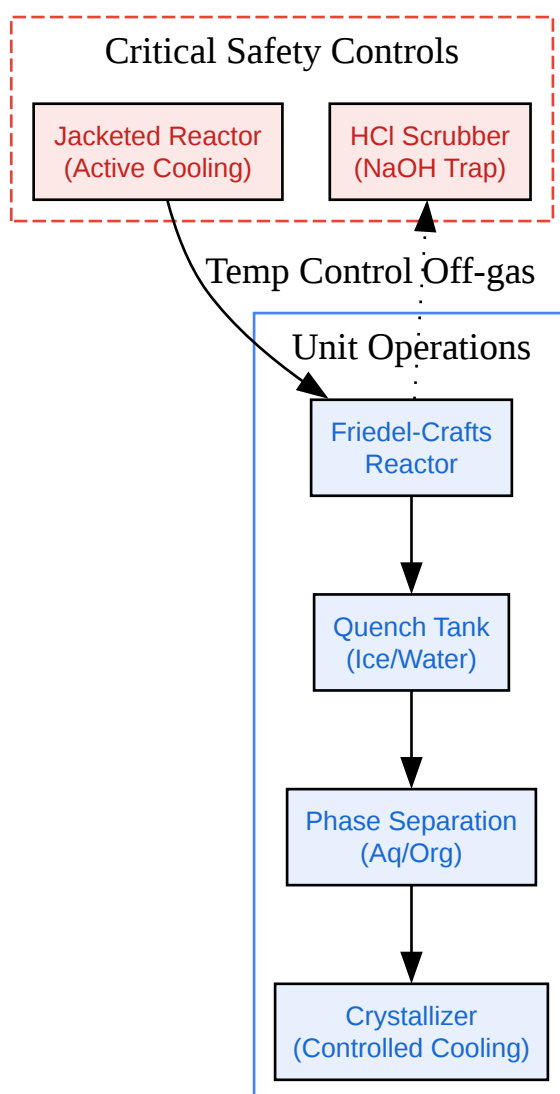

[Click to download full resolution via product page](#)

Figure 2: Process flow highlighting critical safety controls for the acylation step.

Quality Control & Troubleshooting

Issue	Probable Cause	Corrective Action
Low Yield (Step 1)	Incomplete complex formation	Ensure AlCl ₃ /Anhydride are stirred for 30 min before adding substrate.
Incomplete Reduction (Step 2)	Catalyst poisoning or low acidity	Use fresh Pd/C; ensure catalytic mineral acid is present to prevent stopping at the alcohol stage.
Demethylation (Step 3)	Reaction temp too high	Keep cyclization temp <85°C. If using PPA, limit time.
Isomer Contamination	Regioselectivity drift	Verify Step 1 temperature is kept <5°C during addition. High temp favors thermodynamic isomers.

Analytical Specification (Final Product):

- Appearance: White to off-white crystalline solid.
- ¹H NMR (CDCl₃): Characteristic doublets for Isopropyl methyls (~1.2 ppm), Singlet for OMe (~3.8 ppm), Aromatic protons as singlets (para-relationship on ring).
- HPLC Purity: >98.5% (Area %).

References

- Cabrera, E. V., & Banerjee, A. K. (2014).[4] A One-pot Synthesis of **6-Isopropyl-7-methoxy-1-tetralone** and 6-Isopropyl-7-methoxy-2-tetralone. *Organic Preparations and Procedures International*, 46(3), 272–276. [Link\[4\]](#)
- Banerjee, A. K., et al. (2019).[5] Isopropylation of 6-Methoxy-1-tetralone. *Organic Preparations and Procedures International*, 51(4), 389-392. [Link\[5\]](#)
- Vera, W. J., & Banerjee, A. K. (2009).[1] An efficient approach for the synthesis of 6,7-dimethoxy-2-tetralone and 5,6-dimethoxy-1-tetralone. *Arkivoc*, (xi), 228-234.[1] [Link](#)

- Burckhalter, J. H., & Campbell, J. R. (1951). Friedel-Crafts Acylation of 2-Isopropylanisole. Journal of Organic Chemistry. (General reference for regioselectivity in substituted anisoles).
- BenchChem Application Note. Overcoming Challenges in Friedel-Crafts Acylation. [Link](#) (General protocol grounding).

Need Custom Synthesis?

BenchChem offers custom synthesis for rare earth carbides and specific isotopic labeling.

Email: info@benchchem.com or [Request Quote Online](#).

Sources

- 1. arkat-usa.org [arkat-usa.org]
- 2. [Organic Syntheses Procedure](http://orgsyn.org) [orgsyn.org]
- 3. alfa-chemistry.com [alfa-chemistry.com]
- 4. researchgate.net [researchgate.net]
- 5. researchgate.net [researchgate.net]
- To cite this document: BenchChem. [Application Note: Process Development & Scale-Up of 6-Isopropyl-7-methoxy-1-tetralone]. BenchChem, [2026]. [Online PDF]. Available at: [<https://www.benchchem.com/product/b3060310/docs#application-note-process-development-scale-up-of-6-isopropyl-7-methoxy-1-tetralone>]

Disclaimer & Data Validity:

The information provided in this document is for Research Use Only (RUO) and is strictly not intended for diagnostic or therapeutic procedures. While BenchChem strives to provide accurate protocols, we make no warranties, express or implied, regarding the fitness of this product for every specific experimental setup.

Technical Support: The protocols provided are for reference purposes. Unsure if this reagent suits your experiment?

Need Industrial/Bulk Grade? [Request Custom Synthesis Quote](#)

BenchChem

Our mission is to be the trusted global source of essential and advanced chemicals, empowering scientists and researchers to drive progress in science and industry.

Contact

Address: 3281 E Guasti Rd
Ontario, CA 91761, United States
Phone: (601) 213-4426
Email: info@benchchem.com

[Contact our Ph.D. Support Team for a compatibility check](#)