

An In-depth Technical Guide to the Ortho-Substituted Piperidinyl Benzamide Scaffold

Author: BenchChem Technical Support Team. **Date:** April 2026

Compound of Interest

Compound Name: 2-(Piperidin-4-yloxy)benzamide

CAS No.: 907159-01-7

Cat. No.: B3058643

[Get Quote](#)

This guide provides a comprehensive technical overview of the ortho-substituted piperidinyl benzamide scaffold, a privileged structure in modern medicinal chemistry. We will delve into the core chemical principles, structure-activity relationships (SAR), and therapeutic applications that make this scaffold a cornerstone of drug discovery, particularly in the realm of central nervous system (CNS) disorders. This document is intended for researchers, scientists, and drug development professionals seeking to leverage this versatile chemical entity in their own research endeavors.

Introduction: The Significance of a Well-Positioned Scaffold

The benzamide functional group is a common motif in a wide range of pharmaceuticals, known for its ability to form key hydrogen bonding interactions with biological targets.[1][2] When coupled with a piperidine ring, a six-membered nitrogen-containing heterocycle, the resulting piperidinyl benzamide scaffold gains a three-dimensional architecture that is crucial for specific receptor engagement.[3][4]

The "ortho-substitution" on the benzamide's phenyl ring is of particular importance. This seemingly subtle modification can profoundly influence the molecule's conformation, electronic properties, and ultimately, its biological activity. The strategic placement of a substituent at this position can enforce a specific torsional angle between the phenyl ring and the amide bond, a critical factor in optimizing receptor binding and selectivity. This guide will explore the nuances of how this ortho-substitution, in concert with modifications to the piperidine moiety, gives rise to a diverse array of pharmacological activities.

The Core Scaffold: Synthetic Strategies and Chemical Space

The construction of the ortho-substituted piperidinyl benzamide scaffold can be approached through several reliable synthetic routes. The choice of a particular strategy often depends on the desired substitution patterns on both the aromatic ring and the piperidine nucleus.

A common and versatile approach involves the amide coupling of a substituted benzoic acid with a piperidine derivative. This is typically achieved using standard peptide coupling reagents such as 1-Ethyl-3-(3-dimethylaminopropyl)carbodiimide (EDC) or dicyclohexylcarbodiimide (DCC), often in the presence of an activating agent like 1-hydroxybenzotriazole (HOBt).

Alternatively, the synthesis can proceed via the reaction of a substituted benzoyl chloride with the desired piperidine. This method is often high-yielding but may be less tolerant of sensitive functional groups.

Illustrative Synthetic Workflow:

Below is a generalized workflow for the synthesis of an ortho-substituted piperidinyl benzamide.

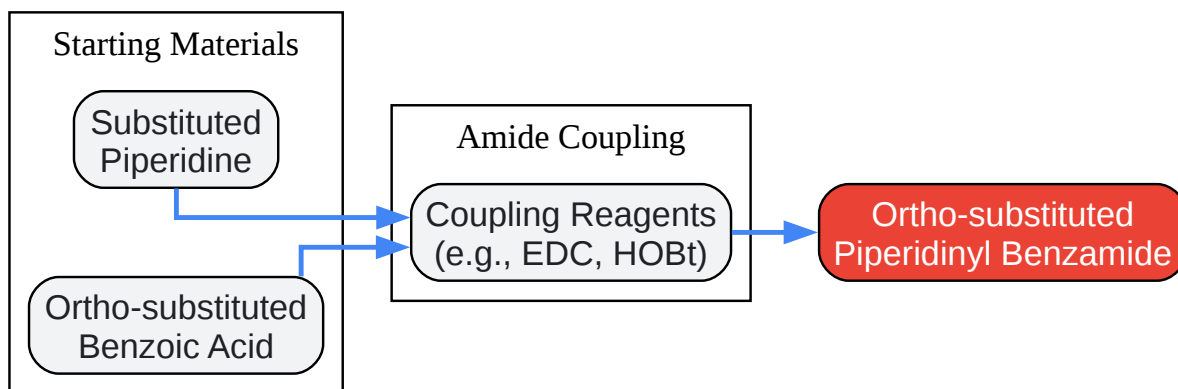

[Click to download full resolution via product page](#)

Caption: Generalized synthetic workflow for ortho-substituted piperidinyll benzamides.

Unlocking Potential: Structure-Activity Relationship (SAR) Insights

The pharmacological profile of the ortho-substituted piperidinyll benzamide scaffold is exquisitely sensitive to structural modifications. A systematic exploration of the SAR is therefore paramount in the design of potent and selective drug candidates.

Key Areas of SAR Exploration:

- **Ortho-Substituent on the Benzamide Ring:** The nature of the ortho-substituent is a critical determinant of activity. Electron-donating groups (e.g., methoxy, amino) and electron-withdrawing groups (e.g., halogens, nitro) can dramatically alter the electronic landscape of the aromatic ring and its interaction with the target protein. Furthermore, the steric bulk of the ortho-substituent can influence the preferred conformation of the molecule, locking it into a bioactive state.
- **Substituents on the Piperidine Ring:** The piperidine ring offers multiple points for diversification. N-alkylation or N-acylation can modulate the basicity of the piperidine nitrogen and introduce additional points of interaction with the target. Substituents on the carbon atoms of the piperidine ring can be used to fine-tune lipophilicity and explore deeper pockets within the binding site.

- The Amide Linker: While less frequently modified, the amide bond itself can be a target for isosteric replacement to improve pharmacokinetic properties such as metabolic stability.

Quantitative SAR Data Summary:

The following table summarizes hypothetical SAR data for a series of ortho-substituted piperidiny benzamides targeting a generic G-protein coupled receptor (GPCR).

Compound	Ortho-Substituent (R1)	Piperidine N-Substituent (R2)	Binding Affinity (K _i , nM)
1a	-OCH ₃	-H	50
1b	-Cl	-H	75
1c	-OCH ₃	-CH ₃	25
1d	-OCH ₃	-CH ₂ CH ₃	60
1e	-Cl	-CH ₃	40

This is a representative table and does not reflect actual experimental data.

Mechanisms of Action: Modulating Key Biological Pathways

Compounds based on the ortho-substituted piperidiny benzamide scaffold have been shown to interact with a variety of biological targets, with a notable prevalence for receptors in the central nervous system.

Dopamine Receptor Antagonism:

A significant number of these compounds act as antagonists at dopamine D2-like receptors (D₂, D₃, and D₄).^[5] This is the primary mechanism of action for their use as antipsychotic and antiemetic agents.^[5] By blocking the binding of dopamine, these compounds modulate downstream signaling pathways, primarily leading to an inhibition of adenylyl cyclase and a subsequent decrease in intracellular cyclic AMP (cAMP) levels.^[5] The atypical antipsychotic drug, amisulpride, is a classic example of a substituted benzamide that exhibits selective

antagonism of dopamine D2 and D3 receptors.[6][7][8] At low doses, it preferentially blocks presynaptic autoreceptors, leading to an increase in dopamine release, which is thought to contribute to its antidepressant effects.[8] At higher doses, it blocks postsynaptic D2/D3 receptors, producing its antipsychotic effects.[6][8]

Signaling Pathway of Dopamine D2 Receptor Antagonism:

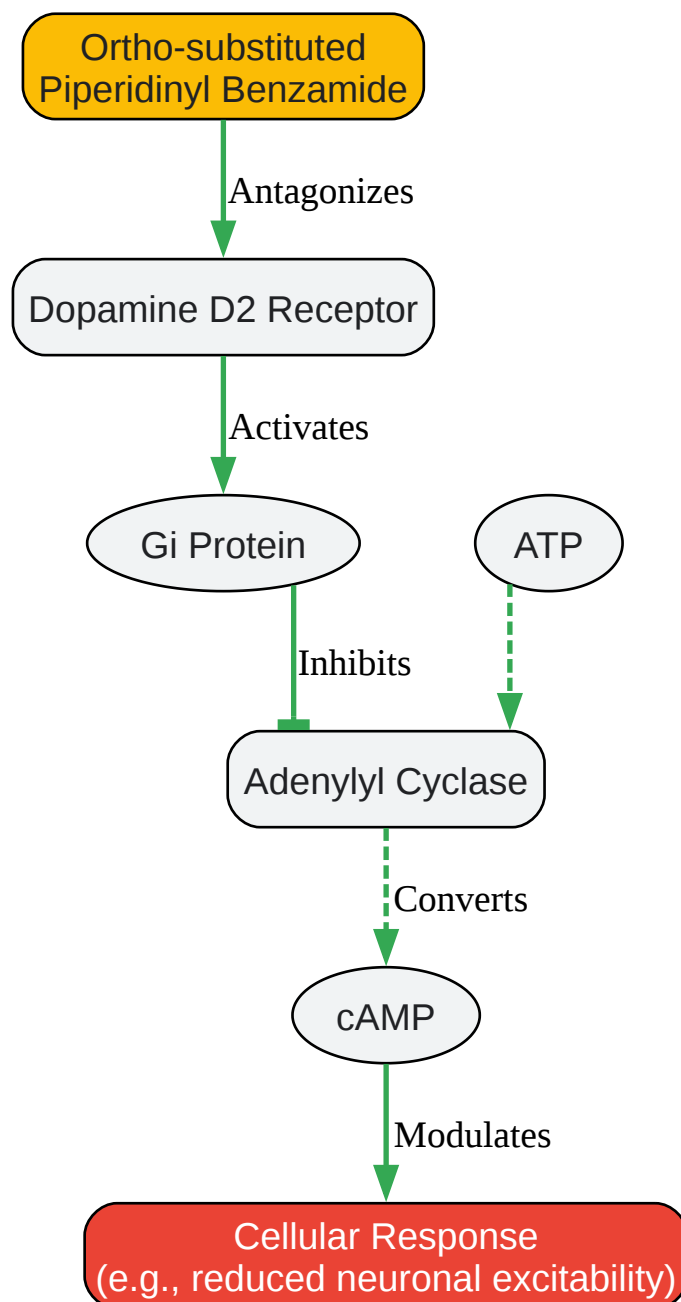

[Click to download full resolution via product page](#)

Caption: Simplified signaling pathway of dopamine D2 receptor antagonism.

Other Potential Targets:

Beyond dopamine receptors, this versatile scaffold has been explored for its activity against a range of other targets, including:

- **Sigma Receptors:** Implicated in a variety of CNS functions and disorders.
- **Serotonin Receptors:** Certain derivatives have shown affinity for various serotonin receptor subtypes, suggesting potential applications in treating mood and anxiety disorders.[6]
- **Enzyme Inhibition:** Some benzamide derivatives have been shown to inhibit enzymes such as histone deacetylases (HDACs), making them of interest in oncology research.[5]

In Practice: A Representative Experimental Protocol

To provide a practical context, the following is a detailed, step-by-step methodology for a key experiment in the characterization of a novel ortho-substituted piperidinyl benzamide.

Protocol: Dopamine D2 Receptor Binding Assay

Objective: To determine the binding affinity (K_i) of a test compound for the human dopamine D2 receptor.

Materials:

- HEK293 cells stably expressing the human dopamine D2 receptor.
- [^3H]-Spiperone (a radiolabeled D2 receptor antagonist).
- Test compound (dissolved in DMSO).
- Haloperidol (a known D2 receptor antagonist, for determining non-specific binding).
- Binding buffer (e.g., 50 mM Tris-HCl, 120 mM NaCl, 5 mM KCl, 2 mM CaCl_2 , 1 mM MgCl_2 , pH 7.4).

- Scintillation vials and scintillation fluid.
- Liquid scintillation counter.

Procedure:

- Membrane Preparation:
 - Harvest the HEK293-D2R cells and homogenize them in ice-cold binding buffer.
 - Centrifuge the homogenate at low speed to remove nuclei and cellular debris.
 - Centrifuge the resulting supernatant at high speed to pellet the cell membranes.
 - Resuspend the membrane pellet in fresh binding buffer and determine the protein concentration using a standard assay (e.g., Bradford assay).
- Binding Assay:
 - In a 96-well plate, add the following to each well:
 - 50 μ L of binding buffer (for total binding).
 - 50 μ L of a high concentration of haloperidol (for non-specific binding).
 - 50 μ L of varying concentrations of the test compound.
 - Add 50 μ L of [3H]-Spiperone to each well.
 - Add 100 μ L of the prepared cell membranes to each well to initiate the binding reaction.
 - Incubate the plate at room temperature for a specified time (e.g., 60 minutes) to allow the binding to reach equilibrium.
- Filtration and Counting:
 - Rapidly filter the contents of each well through a glass fiber filter plate to separate the bound from the free radioligand.

- Wash the filters several times with ice-cold binding buffer to remove any non-specifically bound radioligand.
- Allow the filters to dry, then place them in scintillation vials with scintillation fluid.
- Measure the radioactivity in each vial using a liquid scintillation counter.
- Data Analysis:
 - Calculate the specific binding by subtracting the non-specific binding from the total binding.
 - Plot the specific binding as a function of the test compound concentration.
 - Determine the IC₅₀ value (the concentration of the test compound that inhibits 50% of the specific binding of the radioligand).
 - Calculate the K_i value using the Cheng-Prusoff equation: $K_i = IC_{50} / (1 + [L]/K_d)$, where [L] is the concentration of the radioligand and K_d is its dissociation constant.

Future Perspectives and Emerging Opportunities

The ortho-substituted piperidinyl benzamide scaffold continues to be a fertile ground for drug discovery. Future research is likely to focus on:

- Expanding the Target Space: Exploring the activity of this scaffold against novel and challenging targets, including those outside of the CNS.
- Improving Selectivity: Fine-tuning the substitution patterns to achieve greater selectivity for specific receptor subtypes, thereby reducing off-target effects and improving the therapeutic index.
- Novel Drug Delivery Systems: Developing innovative formulations and delivery strategies to enhance the pharmacokinetic and pharmacodynamic properties of these compounds.

By leveraging the rich chemical space and well-established SAR of the ortho-substituted piperidinyl benzamide scaffold, researchers are well-positioned to develop the next generation of innovative therapeutics for a wide range of debilitating diseases.

References

- Benzamides: Sulpiride - Pharmaguideline. (n.d.).
- Mechanism of Action of Hydroxy-Substituted Benzamides: A Technical Guide - Benchchem. (n.d.).
- Studies on the Mechanism of Action of Substituted Benzamide Drugs - PubMed. (n.d.).
- Studies on the mechanism of action of benzamide riboside: a novel inhibitor of IMP dehydrogenase - PubMed. (2002, April 15).
- Synthesis and structure-activity relationships of a series 4-methoxy-3-(piperidin-4-yl)oxy benzamides as novel inhibitors of the presynaptic choline transporter - PMC. (2015, January 5).
- Synthesis and structure-activity relationships of a series of 4-methoxy-3-(piperidin-4-yl)oxy benzamides as novel inhibitors of the presynaptic choline transporter - PubMed. (2015, April 15).
- Synthesis and structure-activity relationship of N-(piperidin-4-yl)benzamide derivatives as activators of hypoxia-inducible factor 1 pathways - PubMed. (2018, December 15).
- Synthesis and structure-activity relationships of N-{1-[(6-fluoro-2-naphthyl)methyl]piperidin-4-yl}benzamide derivatives as novel CCR3 antagonists - PubMed. (2008, January 1).
- Antipsychotic Benzamides Amisulpride and LB-102 Display Polypharmacy as Racemates, S Enantiomers Engage Receptors D2 and D3, while R Enantiomers Engage 5-HT7 | ACS Omega - ACS Publications. (2019, August 15).
- Structure–activity relationship of piperidine derivatives with... - ResearchGate. (n.d.). Retrieved from [[Link](#)]
- Pharmacological Potential of Benzamide Analogues and their Uses in Medicinal Chemistry - Walsh Medical Media. (2016, November 28).
- Synthesis of N-Substituted Benzamide Derivatives and their Evaluation as Antitumor Agents. (2026, February 9).
- synthesis of novel n-benzyl substituted piperidine amides of 1h-indole-5-carboxylic acid as potential inhibitors of cholinesterases. (n.d.).
- The substituted benzamides and their clinical potential on dysthymia and on the negative symptoms of schizophrenia - PubMed. (n.d.).
- Piperidine Derivatives: Recent Advances in Synthesis and Pharmacological Applications. (2023, February 2).
- Synthesis and Biological Activity of Benzamides Substituted with Pyridine-Linked 1,2,4-Oxadiazole - PubMed. (2020, July 31).
- Consensus on the use of substituted benzamides in psychiatric patients - PubMed. (n.d.).

- Does Ortho-Substitution Enhance Cytotoxic Potencies in a Series of 3,5-Bis(benzylidene)-4-piperidones? - PubMed. (2024, October 30).
- Synthesis of novel N-benzyl substituted piperidine amides of 1H-indole-5-carboxylic acid as potential inhibitors of cholinesterases - PubMed. (2012, May 15).
- Synthesis, dynamic NMR characterization and XRD studies of novel N,N'-substituted piperazines for bioorthogonal labeling - PMC. (2016, November 21).
- Piperazine Derivatives: A Privileged Scaffold in Modern Synthesis and Medicinal Chemistry. (2026, January 19).
- A Comparative Analysis of N-Substituted Benzamides on Bioactivity: A Guide for Drug Development Professionals - Benchchem. (n.d.).
- Piperazine Derivatives: A Privileged Scaffold in Modern Synthesis and Medicinal Chemistry. (2025, November 19).

Need Custom Synthesis?

BenchChem offers custom synthesis for rare earth carbides and specific isotopic labeling.

Email: info@benchchem.com or [Request Quote Online](#).

Sources

- [1. Benzamides: Sulpiride | Pharmaguideline \[pharmaguideline.com\]](#)
- [2. walshmedicalmedia.com \[walshmedicalmedia.com\]](#)
- [3. researchgate.net \[researchgate.net\]](#)
- [4. mdpi.com \[mdpi.com\]](#)
- [5. pdf.benchchem.com \[pdf.benchchem.com\]](#)
- [6. pubs.acs.org \[pubs.acs.org\]](#)
- [7. The substituted benzamides and their clinical potential on dysthymia and on the negative symptoms of schizophrenia - PubMed \[pubmed.ncbi.nlm.nih.gov\]](#)
- [8. Consensus on the use of substituted benzamides in psychiatric patients - PubMed \[pubmed.ncbi.nlm.nih.gov\]](#)
- To cite this document: BenchChem. [An In-depth Technical Guide to the Ortho-Substituted Piperidinyl Benzamide Scaffold]. BenchChem, [2026]. [Online PDF]. Available at: [\[https://www.benchchem.com/product/b3058643/docs#an-in-depth-technical-guide-to-the-ortho-substituted-piperidinyl-benzamide-scaffold\]](https://www.benchchem.com/product/b3058643/docs#an-in-depth-technical-guide-to-the-ortho-substituted-piperidinyl-benzamide-scaffold)

Disclaimer & Data Validity:

The information provided in this document is for Research Use Only (RUO) and is strictly not intended for diagnostic or therapeutic procedures. While BenchChem strives to provide accurate protocols, we make no warranties, express or implied, regarding the fitness of this product for every specific experimental setup.

Technical Support: The protocols provided are for reference purposes. Unsure if this reagent suits your experiment?

Need Industrial/Bulk Grade? [Request Custom Synthesis Quote](#)

BenchChem

Our mission is to be the trusted global source of essential and advanced chemicals, empowering scientists and researchers to drive progress in science and industry.

Contact

Address: 3281 E Guasti Rd
Ontario, CA 91761, United States
Phone: (601) 213-4426
Email: info@benchchem.com

[Contact our Ph.D. Support Team for a compatibility check](#)