

Technical Support Center: Enhancing F420 Production in Microbial Systems

Author: BenchChem Technical Support Team. **Date:** May 2026

Compound of Interest

Compound Name: *coenzyme F420*

CAS No.: 64885-97-8

Cat. No.: B3055463

[Get Quote](#)

Welcome to the technical support center for addressing the low production of cofactor F420 in natural microbial producers. This resource is designed for researchers, scientists, and drug development professionals to troubleshoot common issues and provide standardized protocols for enhancing F420 yields.

Frequently Asked Questions (FAQs)

Q1: What is cofactor F420 and why is its low production a concern?

A1: Cofactor F420 is a deazaflavin derivative with a redox potential similar to NAD(P)⁺, making it a crucial hydride carrier in various microbial metabolic pathways.^[1] It plays a significant role in methanogenesis, the biosynthesis of antibiotics, and the activation of prodrugs for treating diseases like tuberculosis.^{[2][3][4]} The low natural production of F420 in many microorganisms presents a significant bottleneck for both fundamental research into F420-dependent enzymes and the development of novel biocatalytic processes.^[5]

Q2: Which microorganisms are natural producers of F420?

A2: F420 was initially discovered in methanogenic archaea.[5] However, it is also found in a variety of bacteria, particularly within the phylum Actinobacteria, including genera like Mycobacterium, Streptomyces, and Rhodococcus.[6] Its distribution is wider than initially thought, with biosynthetic gene clusters identified in various other bacterial phyla.[6]

Q3: What are the key genes involved in the F420 biosynthesis pathway?

A3: The core F420 biosynthesis pathway involves several key enzymes. In bacteria, these are typically encoded by the *fbiA*, *fbiB*, and *fbiC* (or *cofC*) and *fbiD* genes.[3][7][8]

- *FbiC/CofG/H*: Catalyzes the formation of the deazaflavin core structure (FO).
- *FbiD/CofC*: Involved in the synthesis of the phospholactyl moiety. Recent research has shown that phosphoenolpyruvate (PEP) is a key precursor.[3][7]
- *FbiA/CofD*: Adds the phospholactyl group to FO to form F420-0.
- *FbiB/CofE*: A glutamyl ligase that adds glutamate residues to F420-0, forming the final F420 cofactor with a polyglutamate tail.[8]

Q4: Can F420 be produced in common laboratory strains like *E. coli*?

A4: Yes, the F420 biosynthesis pathway has been successfully expressed heterologously in *Escherichia coli*. [3][7][9] However, optimizing production in *E. coli* often requires metabolic engineering to enhance the supply of precursors like phosphoenolpyruvate (PEP). [10]

Troubleshooting Guide

This guide addresses common problems encountered during experiments aimed at increasing F420 production.

Symptom	Possible Cause	Suggested Solution
1. Low or no detectable F420 in culture extracts.	Inefficient cell lysis and F420 extraction.	Ensure complete cell disruption. Use a proven method like sonication or bead beating in an appropriate lysis buffer. Protect the extract from light and heat to prevent F420 degradation. [2] [7]
Suboptimal growth conditions.	Optimize culture parameters such as temperature, pH, and aeration. These factors significantly influence secondary metabolite production. [1] [11]	
Incorrect media composition.	The availability of precursors is critical. Ensure the medium contains sufficient carbon and nitrogen sources, as well as essential minerals. For example, tyrosine is a precursor for the deazaflavin ring. [12]	
F420 degradation.	F420 is light-sensitive. Perform all extraction and analysis steps in the dark or under amber light to minimize photodegradation. Store extracts at -20°C or below.	
2. High cell density but low F420 yield.	Nutrient limitation triggering growth but not secondary metabolism.	Secondary metabolite production is often induced under specific nutrient-limiting conditions (e.g., phosphate or nitrogen limitation) after the primary growth phase. [8] Design a two-stage cultivation

strategy or use a medium that becomes limiting for a specific nutrient after sufficient biomass has accumulated.

Feedback inhibition of biosynthesis pathway.	Overexpression of efflux pumps or in situ product removal strategies may alleviate feedback inhibition.	
Suboptimal expression of F420 biosynthesis genes.	If using a heterologous or overexpressing host, verify the expression of the biosynthetic genes (fbiA, fbiB, fbiC/cofC, fbiD) using RT-qPCR or proteomics. Codon-optimize the genes for the expression host.	
3. Inconsistent F420 production between batches.	Variability in inoculum preparation.	Standardize the age, size, and physiological state of the inoculum. Use a consistent protocol for preparing starter cultures.
Inconsistent media preparation or sterilization.	Ensure precise measurement of all media components and a consistent sterilization process. Over-sterilization can degrade essential media components.	
Fluctuations in fermentation conditions.	Tightly control and monitor pH, temperature, and dissolved oxygen levels throughout the fermentation process. ^[1]	
4. Accumulation of F420 precursors (e.g., FO).	Bottleneck in the F420 biosynthesis pathway.	Overexpression of the downstream enzymes (e.g., FbiA and FbiB) may help to convert the accumulated

precursor.^[13] Ensure the necessary co-substrates for these enzymes are available.

Low activity of a specific biosynthetic enzyme.	Investigate the specific activity of the enzymes in the pathway. If a particular enzyme shows low activity, consider protein engineering to improve its performance.
---	---

Experimental Protocols

Protocol 1: Extraction and Quantification of F420 by HPLC

This protocol describes the extraction of F420 from bacterial cells and its quantification using High-Performance Liquid Chromatography (HPLC) with fluorescence detection.^{[2][3][7]}

Materials:

- Lysis Buffer: 50 mM Tris-HCl pH 7.5, 100 mM NaCl, 1 mM DTT
- Acetonitrile (ACN), HPLC grade
- Methanol (MeOH), HPLC grade
- Ammonium acetate
- C18 HPLC column
- Fluorescence detector (Excitation: 420 nm, Emission: 470 nm)

Procedure:

- Cell Harvesting: Centrifuge the microbial culture at 5,000 x g for 10 minutes at 4°C. Discard the supernatant and wash the cell pellet with sterile water.

- Cell Lysis: Resuspend the cell pellet in ice-cold Lysis Buffer. Lyse the cells using a suitable method (e.g., sonication on ice or bead beating).
- Clarification: Centrifuge the lysate at 15,000 x g for 20 minutes at 4°C to pellet cell debris.
- Protein Precipitation: To the supernatant, add an equal volume of ice-cold 100% methanol. Incubate at -20°C for 30 minutes to precipitate proteins.
- Final Clarification: Centrifuge at 15,000 x g for 20 minutes at 4°C. Collect the supernatant containing F420.
- HPLC Analysis:
 - Filter the supernatant through a 0.22 µm syringe filter.
 - Inject the sample onto the C18 column.
 - Use a gradient of mobile phase A (10 mM ammonium acetate, pH 6.5) and mobile phase B (100% acetonitrile). A typical gradient is 5-95% B over 20 minutes.
 - Monitor the fluorescence at an excitation wavelength of 420 nm and an emission wavelength of 470 nm.
 - Quantify the F420 peak area against a standard curve prepared with purified F420.

Protocol 2: Construction of an F420 Overproducing Strain

This protocol outlines the general steps for creating a microbial strain that overproduces F420 through the overexpression of its biosynthetic genes.

Materials:

- High-fidelity DNA polymerase
- Restriction enzymes and T4 DNA ligase (or a seamless cloning kit)
- Expression vector suitable for the host organism

- Competent cells of the desired host strain (e.g., *E. coli* or *M. smegmatis*)

Procedure:

- **Gene Amplification:** Amplify the F420 biosynthetic genes (*fbiA*, *fbiB*, *fbiC/cofC*, *fbiD*) from the genomic DNA of a natural producer using PCR with primers containing appropriate restriction sites or overlaps for seamless cloning.
- **Vector Preparation:** Digest the expression vector with the corresponding restriction enzymes.
- **Ligation/Cloning:** Ligate the amplified genes into the prepared vector to create an expression plasmid. It is often beneficial to clone the genes as a synthetic operon with ribosome binding sites for each gene to ensure coordinated expression.
- **Transformation:** Transform the ligation product into competent cells of the expression host.
- **Verification:** Select for transformants on appropriate antibiotic-containing media. Verify the correct insertion of the genes by colony PCR and DNA sequencing.
- **Expression and Analysis:** Culture the engineered strain and induce gene expression. Analyze F420 production as described in Protocol 1.

Data Presentation

Table 1: Comparison of F420 Production in Different Microbial Hosts

Microorganism	Production Method	F420 Yield (mg/L)	Reference
Methanobacterium thermoautotrophicum	Wild-type	~0.5 - 1.0	[14]
Mycobacterium smegmatis	Wild-type	~0.1 - 0.3	[13]
Mycobacterium smegmatis	Overexpression of fbiABC	~1.0 - 3.0	[15]
Escherichia coli	Heterologous expression of F420 pathway	~0.5 - 1.5	[9]
Escherichia coli	Metabolically engineered	> 5.0	[10]

Visualizations

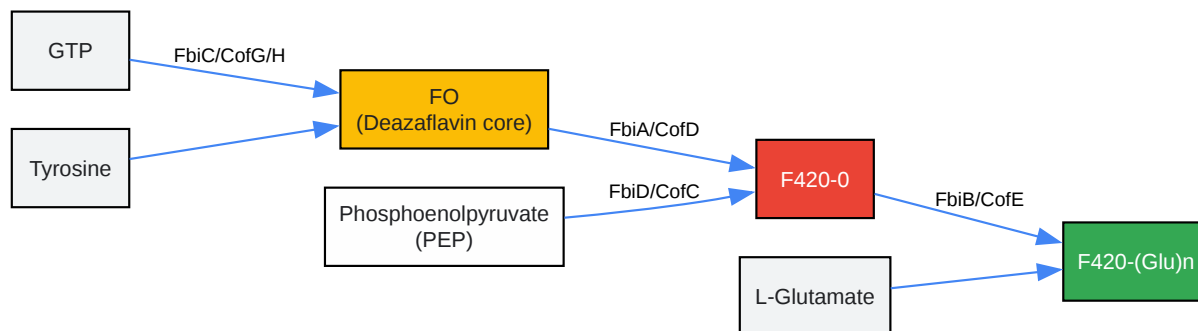

[Click to download full resolution via product page](#)

Caption: Bacterial F420 Biosynthesis Pathway.

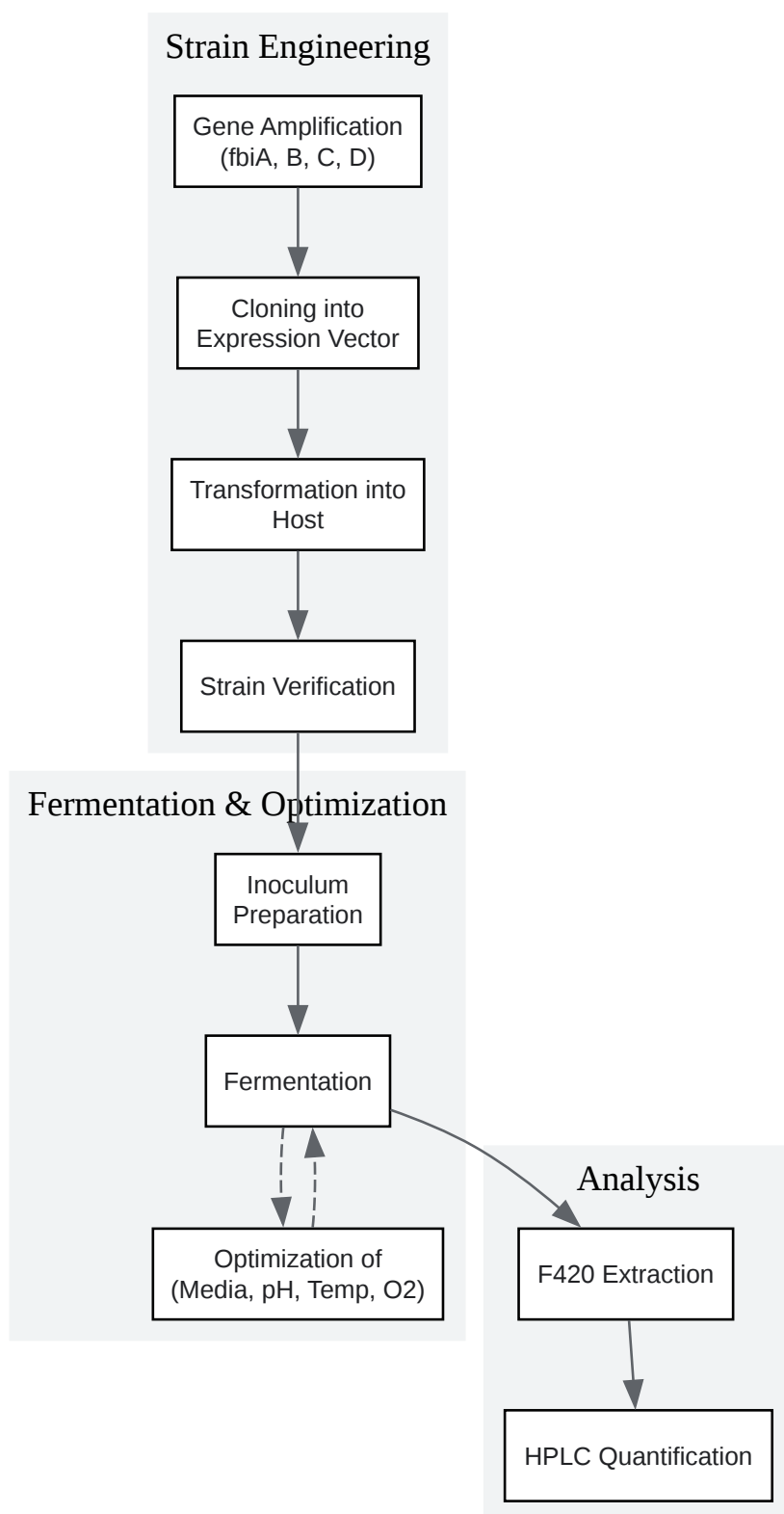

[Click to download full resolution via product page](#)

Caption: Workflow for Enhancing F420 Production.

Need Custom Synthesis?

BenchChem offers custom synthesis for rare earth carbides and specific isotopic labeling.

Email: info@benchchem.com or [Request Quote Online](#).

References

- [1. Step-by-Step Guide to Fermentation Optimization in Small Labs \[synapse.patsnap.com\]](#)
- [2. Extraction of Cofactor F420 for Analysis of Polyglutamate Tail Length from Methanogenic Pure Cultures and Environmental Samples \[jove.com\]](#)
- [3. Extraction of Cofactor F420 for Analysis of Polyglutamate Tail Length from Methanogenic Pure Cultures and Environmental Samples - PubMed \[pubmed.ncbi.nlm.nih.gov\]](#)
- [4. Strategies for Fermentation Medium Optimization: An In-Depth Review - PMC \[pmc.ncbi.nlm.nih.gov\]](#)
- [5. academic.oup.com \[academic.oup.com\]](#)
- [6. Pilot Scale Production of a F420 Precursor Under Microaerobic Conditions - PMC \[pmc.ncbi.nlm.nih.gov\]](#)
- [7. researchgate.net \[researchgate.net\]](#)
- [8. benchchem.com \[benchchem.com\]](#)
- [9. researchgate.net \[researchgate.net\]](#)
- [10. researchgate.net \[researchgate.net\]](#)
- [11. Exploring Structural Diversity of Microbe Secondary Metabolites Using OSMAC Strategy: A Literature Review - PMC \[pmc.ncbi.nlm.nih.gov\]](#)
- [12. researchgate.net \[researchgate.net\]](#)
- [13. Metabolic Engineering of Cofactor F420 Production in Mycobacterium smegmatis - PMC \[pmc.ncbi.nlm.nih.gov\]](#)
- [14. Large-Scale Production of Coenzyme F420-5,6 by Using Mycobacterium smegmatis - PMC \[pmc.ncbi.nlm.nih.gov\]](#)
- [15. Metabolic engineering of cofactor F420 production in Mycobacterium smegmatis - PubMed \[pubmed.ncbi.nlm.nih.gov\]](#)
- To cite this document: BenchChem. [Technical Support Center: Enhancing F420 Production in Microbial Systems]. BenchChem, [2026]. [Online PDF]. Available at:

[<https://www.benchchem.com/product/b3055463/docs#technical-support-center-enhancing-f420-production-in-microbial-systems>]

Disclaimer & Data Validity:

The information provided in this document is for Research Use Only (RUO) and is strictly not intended for diagnostic or therapeutic procedures. While BenchChem strives to provide accurate protocols, we make no warranties, express or implied, regarding the fitness of this product for every specific experimental setup.

Technical Support: The protocols provided are for reference purposes. Unsure if this reagent suits your experiment?

Need Industrial/Bulk Grade? [Request Custom Synthesis Quote](#)

BenchChem

Our mission is to be the trusted global source of essential and advanced chemicals, empowering scientists and researchers to drive progress in science and industry.

Contact

Address: 3281 E Guasti Rd
Ontario, CA 91761, United States
Phone: (601) 213-4426
Email: info@benchchem.com

[Contact our Ph.D. Support Team for a compatibility check](#)