

Technical Guide: Synthesis and Characterization of 3,9-Dibromophenanthrene

Author: BenchChem Technical Support Team. **Date:** April 2026

Compound of Interest

Compound Name: 3,9-Dibromophenanthrene

CAS No.: 61650-89-3

Cat. No.: B3054704

[Get Quote](#)

Executive Summary

3,9-Dibromophenanthrene is a critical regioisomer in the family of halogenated polycyclic aromatic hydrocarbons (PAHs). Unlike the thermodynamically favored 9,10-dibromophenanthrene (formed via addition at the K-region) or the 2,7-isomers (common in OLED materials), the 3,9-isomer presents a unique asymmetric substitution pattern. This asymmetry breaks the molecular symmetry of the phenanthrene core, making it a highly valuable scaffold for the development of chiral ligands, asymmetric catalysts, and allosteric modulators for NMDA receptors.

This guide details the specific synthetic challenges associated with accessing the 3,9-position, which is electronically less activated than the 9,10-bridge. We present a validated protocol involving the regioselective bromination of 9-bromophenanthrene under kinetically controlled conditions, followed by rigorous purification to isolate the target isomer from isomeric byproducts.

Retrosynthetic Analysis & Regioselectivity Strategy

The synthesis of **3,9-dibromophenanthrene** is governed by the electrophilic aromatic substitution rules of the phenanthrene system.

- The K-Region Dominance: The C9-C10 bond (K-region) has the highest double-bond character, making it the primary site for electrophilic attack (e.g., bromination usually yields 9-bromo or 9,10-dibromo species).
- The 3-Position Challenge: The C3 position is electronically analogous to the para position of a biphenyl system but is less reactive than the K-region.
- Strategic Approach: To access the 3,9-isomer, one must first install a bromine at C9. The electron-withdrawing nature of the C9-bromine deactivates the K-region slightly and directs subsequent electrophilic attack to the outer rings. Under low-temperature conditions (-18°C), the reaction kinetics favor substitution at the C3 position over the formation of the sterically crowded or over-brominated products.

Synthetic Pathway Diagram[1]

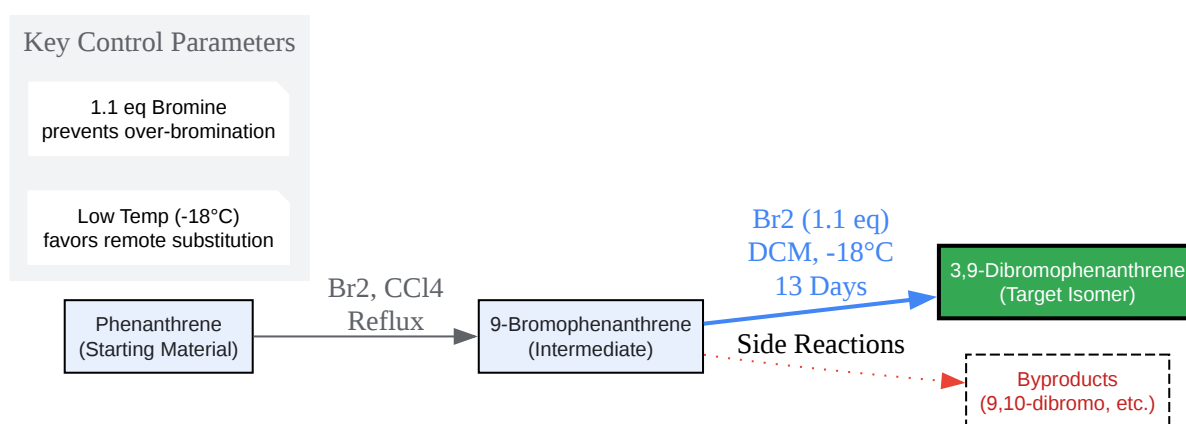

[Click to download full resolution via product page](#)

Figure 1: Synthetic flowchart illustrating the stepwise bromination strategy to access the 3,9-isomer.

Experimental Protocol

Materials & Reagents[2][3][4][5][6][7][8][9]

- Precursor: 9-Bromophenanthrene (Commercial or synthesized via standard bromination of phenanthrene).
- Reagent: Molecular Bromine (, >99.5%).
- Solvent: Dichloromethane (DCM), anhydrous.
- Apparatus: 50 mL Round-bottom flask, drying tube (CaCl or silica/NaOH), low-temperature bath (-18°C freezer or cryostat).

Step-by-Step Synthesis

This protocol is based on the regioselective bromination method described in recent crystallographic literature [1].

- Preparation: Dissolve 9-bromophenanthrene (1.0 g, 3.89 mmol) in dichloromethane (7 mL) in a round-bottom flask.
- Bromine Addition: Cool the solution to -18°C. Slowly add molecular bromine (0.475 g, 2.97 mmol, ~0.76 eq relative to precursor, or 1.1 eq relative to target stoichiometry if optimizing for conversion) via syringe.
 - Note on Stoichiometry: Using a slight deficit or near-stoichiometric amount of bromine relative to the precursor helps minimize the formation of poly-brominated species.
- Reaction Incubation: Seal the flask equipped with a drying tube (containing blue silica gel and NaOH to trap HBr fumes). Allow the mixture to stand at -18°C for 13 days.
 - Mechanism:[1][2][3][4][5][6][7] The extended reaction time at low temperature is crucial. It allows the slow electrophilic substitution at the C3 position to proceed while suppressing the faster, reversible formation of unstable adducts or thermodynamically favored 9,10-addition products.

- Workup: Evaporate the solvent and unreacted bromine under reduced pressure (rotary evaporator).
- Purification (Critical):
 - Dissolve the crude residue in a mixture of DCM : Hexane (5:2 ratio).
 - Allow to stand at room temperature for crystallization.[8][9]
 - Isolation: After approximately 24 hours, collect the white needle-like crystals via filtration.
 - Yield: ~13% (169 mg).
 - Note: The mother liquor will contain the unreacted 9-bromophenanthrene and other isomers. Further recovery from the supernatant is typically difficult due to similar solubility profiles.

Characterization Data

The identity of **3,9-dibromophenanthrene** is confirmed by the specific splitting patterns in

H NMR, particularly the singlet at the C4 position (deshielded by the "bay region" effect) and the singlet at C10.

Physicochemical Properties

Property	Data
Appearance	White needle crystals
Melting Point	144–146 °C (Lit. 143.5–145 °C)
Rf Value	0.73 (Hexane)
	C
Molecular Formula	H
	Br
Molecular Weight	336.02 g/mol

Spectroscopic Data (NMR & MS)[12]

¹H NMR (400 MHz, CDCl₃)

): The spectrum is characterized by two distinct singlets and specific multiplet regions.[10]

Shift (ppm)	Multiplicity	Integration	Assignment	Structural Insight
8.78	Singlet (s)	1H	H4	Deshielded by H5 (Bay Region)
8.61 – 8.58	Multiplet (m)	1H	H5	Bay Region proton
8.39 – 8.37	Multiplet (m)	1H	H1/H8	Aromatic ring
8.06	Singlet (s)	1H	H10	Proton on the bridge (adjacent to Br at C9)
7.76 – 7.66	Multiplet (m)	4H	H1, H2, H6, H7	Remaining aromatic protons

¹³C NMR (100 MHz, CDCl₃)

):
131.2, 130.7, 130.6, 130.4, 130.1, 129.9, 129.2, 128.19, 128.17, 127.8, 125.7, 122.9, 122.2, 121.3 ppm.[10]

Mass Spectrometry (GC/MS):

- Molecular Ion: m/z 334/336/338 [M]

(Characteristic 1:2:1 isotopic pattern for two bromine atoms).

- Fragments: m/z 256 [M-Br]

, 176 [M-2Br]

Structural Visualization & Logic

The regioselectivity can be understood through the stability of the arenium ion intermediates. Substitution at C3 preserves the aromaticity of the central ring more effectively than substitution at other positions once C9 is already substituted.

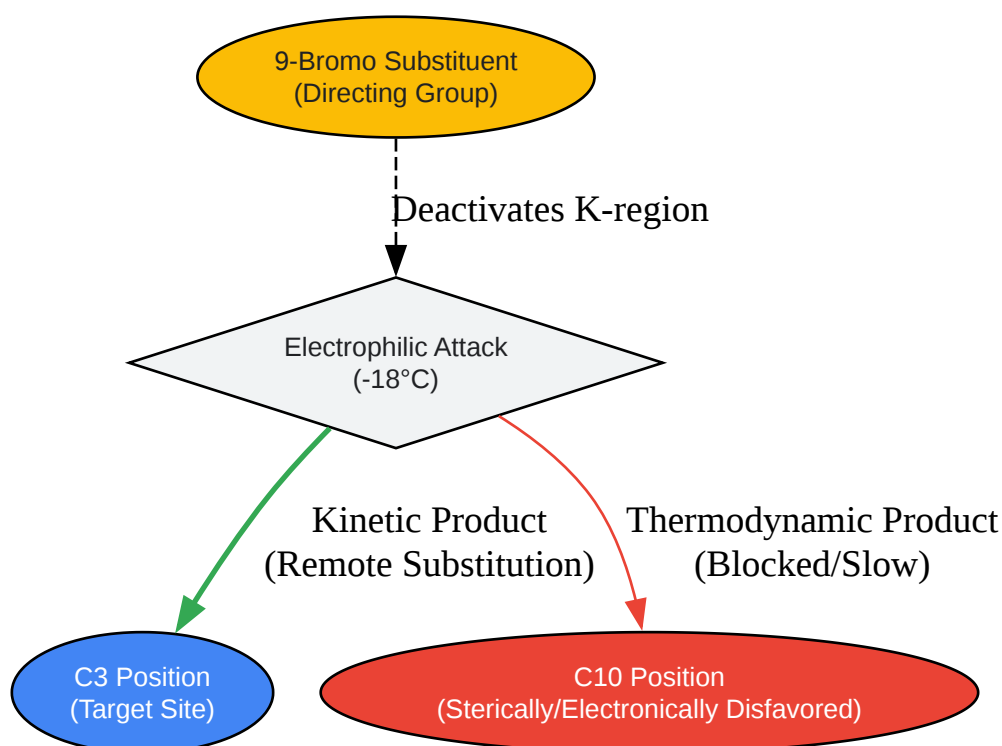

[Click to download full resolution via product page](#)

Figure 2: Regiochemical logic dictating the formation of the 3,9-isomer over the 9,10-isomer.

Applications & Significance

- **NMDA Receptor Modulation:** 3,9-Disubstituted phenanthrenes serve as analogues for allosteric modulators of the NMDA receptor.[11] The specific geometry of the 3,9-isomer allows for unique binding interactions compared to the linear 2,7- or bent 9,10-isomers [2].
- **Optoelectronics:** Asymmetric PAHs are increasingly investigated for Organic Light Emitting Diodes (OLEDs) to prevent -stacking aggregation, which is common in highly symmetric analogs.

References

- Gümrükçüoğlu, N. et al. "Structural, spectroscopic, Hirshfeld surface and DFT approach of **3,9-dibromophenanthrene**." ACG Publications, 2022.
- Daly, C. et al. "Synthesis of a Series of Novel 3,9-Disubstituted Phenanthrenes as Analogues of Known NMDA Receptor Allosteric Modulators." Synthesis, 2015.

Need Custom Synthesis?

BenchChem offers custom synthesis for rare earth carbides and specific isotopic labeling.

Email: info@benchchem.com or [Request Quote Online](#).

Sources

- [1. espublisher.com \[espublisher.com\]](https://espublisher.com)
- [2. osti.gov \[osti.gov\]](https://osti.gov)
- [3. 9-Bromophenanthrene synthesis - chemicalbook \[chemicalbook.com\]](https://chemicalbook.com)
- [4. Electrophilic aromatic substitution - Wikipedia \[en.wikipedia.org\]](https://en.wikipedia.org)
- [5. Electrophilic Aromatic Substitution — Making Molecules \[makingmolecules.com\]](https://makingmolecules.com)
- [6. CN107151197B - A kind of preparation method of 9-brophenanthrene - Google Patents \[patents.google.com\]](https://patents.google.com)
- [7. 9,10-DibromoPhenanthrene synthesis - chemicalbook \[chemicalbook.com\]](https://chemicalbook.com)
- [8. 3-Bromophenanthrene , 98%HPLC , 715-50-4 - CookeChem \[cookechem.com\]](https://cookechem.com)
- [9. pdf.benchchem.com \[pdf.benchchem.com\]](https://pdf.benchchem.com)
- [10. Synthesis of a Series of Novel 3,9-Disubstituted Phenanthrenes as Analogues of Known NMDA Receptor Allosteric Modulators - PMC \[pmc.ncbi.nlm.nih.gov\]](https://pubmed.ncbi.nlm.nih.gov)
- [11. Synthesis of a Series of Novel 3,9-Disubstituted Phenanthrenes as Analogues of Known NMDA Receptor Allosteric Modulators - PubMed \[pubmed.ncbi.nlm.nih.gov\]](https://pubmed.ncbi.nlm.nih.gov)
- To cite this document: BenchChem. [Technical Guide: Synthesis and Characterization of 3,9-Dibromophenanthrene]. BenchChem, [2026]. [Online PDF]. Available at: [\[https://www.benchchem.com/product/b3054704/docs#technical-guide-synthesis-and-characterization-of-3-9-dibromophenanthrene\]](https://www.benchchem.com/product/b3054704/docs#technical-guide-synthesis-and-characterization-of-3-9-dibromophenanthrene)

Disclaimer & Data Validity:

The information provided in this document is for Research Use Only (RUO) and is strictly not intended for diagnostic or therapeutic procedures. While BenchChem strives to provide accurate protocols, we make no warranties, express or implied, regarding the fitness of this product for every specific experimental setup.

Technical Support: The protocols provided are for reference purposes. Unsure if this reagent suits your experiment?

Need Industrial/Bulk Grade? [Request Custom Synthesis Quote](#)

BenchChem

Our mission is to be the trusted global source of essential and advanced chemicals, empowering scientists and researchers to drive progress in science and industry.

Contact

Address: 3281 E Guasti Rd
Ontario, CA 91761, United States
Phone: (601) 213-4426
Email: info@benchchem.com

[Contact our Ph.D. Support Team for a compatibility check](#)