

A Comparative Guide to the Mass Spectrometry Fragmentation Patterns of Nitrophenyl Triazoles

Author: BenchChem Technical Support Team. **Date:** April 2026

Compound of Interest

Compound Name:	3-(4-nitrophenyl)-1H-1,2,4-triazole
CAS No.:	6219-52-9
Cat. No.:	B3054860

[Get Quote](#)

This guide provides an in-depth comparison of the mass spectrometry fragmentation patterns of nitrophenyl triazole isomers. Designed for researchers, scientists, and professionals in drug development, this document elucidates the distinct fragmentation pathways of ortho-, meta-, and para-substituted nitrophenyl triazoles under both Electron Ionization (EI) and Electrospray Ionization (ESI) conditions. Understanding these patterns is crucial for the unambiguous identification and characterization of these important chemical entities in complex matrices.

Introduction: The Significance of Fragmentation Analysis

Nitrophenyl triazoles are a class of heterocyclic compounds with a broad spectrum of applications, including in medicinal chemistry and materials science. The specific substitution pattern of the nitro group on the phenyl ring significantly influences the molecule's chemical and biological properties. Mass spectrometry is an indispensable tool for the structural elucidation of these isomers. However, their identical molecular weight necessitates a detailed analysis of their fragmentation patterns to differentiate them. This guide provides a comparative analysis of these patterns, offering insights into the underlying fragmentation mechanisms.

Ionization Techniques: A Head-to-Head Comparison for Nitrophenyl Triazole Analysis

The choice of ionization technique is paramount in determining the nature and extent of fragmentation. Here, we compare the two most common techniques, Electron Ionization (EI) and Electrospray Ionization (ESI), for the analysis of nitrophenyl triazoles.

Electron Ionization (EI): As a "hard" ionization technique, EI imparts significant energy to the analyte molecule, leading to extensive and often complex fragmentation. This results in a rich fragmentation pattern that can be considered a "fingerprint" for a specific isomer. EI is particularly useful for distinguishing between the ortho, meta, and para isomers of nitrophenyl triazoles due to the influence of the nitro group's position on the fragmentation cascade.

Electrospray Ionization (ESI): In contrast, ESI is a "soft" ionization technique that typically results in the formation of a protonated molecule, $[M+H]^+$, with minimal fragmentation. While this is advantageous for determining the molecular weight of the compound, it provides limited structural information for distinguishing between isomers in a single-stage mass spectrometry experiment. However, when coupled with tandem mass spectrometry (MS/MS), ESI can be used to induce fragmentation through collision-induced dissociation (CID), providing valuable structural insights.

Electron Ionization (EI) Fragmentation Patterns: A Tale of Three Isomers

Under electron ionization, the fragmentation of nitrophenyl triazoles is heavily influenced by the position of the nitro group on the phenyl ring. The following sections detail the proposed fragmentation pathways for the ortho, meta, and para isomers.

The "Ortho Effect" in 1-(2-Nitrophenyl)-1,2,3-triazole

The proximity of the nitro group to the triazole ring in the ortho isomer leads to a unique fragmentation pathway known as the "ortho effect." This involves an intramolecular interaction between the two groups, resulting in characteristic fragment ions not observed for the meta and para isomers.

A key fragmentation pathway for the ortho isomer is the loss of a hydroxyl radical ($\bullet\text{OH}$) from the molecular ion, followed by the elimination of N_2 and CO . This is a hallmark of the ortho effect in many nitroaromatic compounds.

Proposed EI Fragmentation Pathway of 1-(2-Nitrophenyl)-1,2,3-triazole

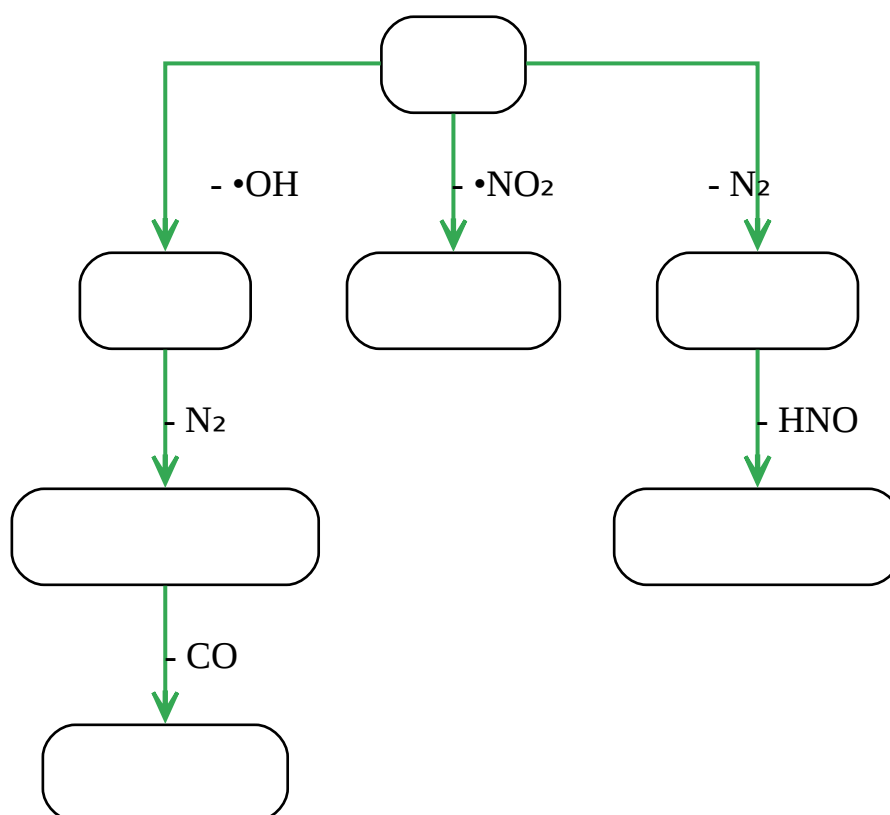

[Click to download full resolution via product page](#)

Caption: Proposed EI fragmentation of 1-(2-nitrophenyl)-1,2,3-triazole.

Fragmentation of 1-(3-Nitrophenyl)-1,2,3-triazole

The meta isomer is expected to exhibit a fragmentation pattern that is more straightforward than the ortho isomer, as the nitro group is not in close proximity to the triazole ring to induce an ortho effect. The fragmentation will likely be dominated by the characteristic losses associated with both the nitrophenyl and triazole moieties.

Key fragmentation pathways are expected to include the loss of the nitro group (NO_2) and the sequential loss of nitrogen (N_2) from the triazole ring.

Proposed EI Fragmentation Pathway of 1-(3-Nitrophenyl)-1,2,3-triazole

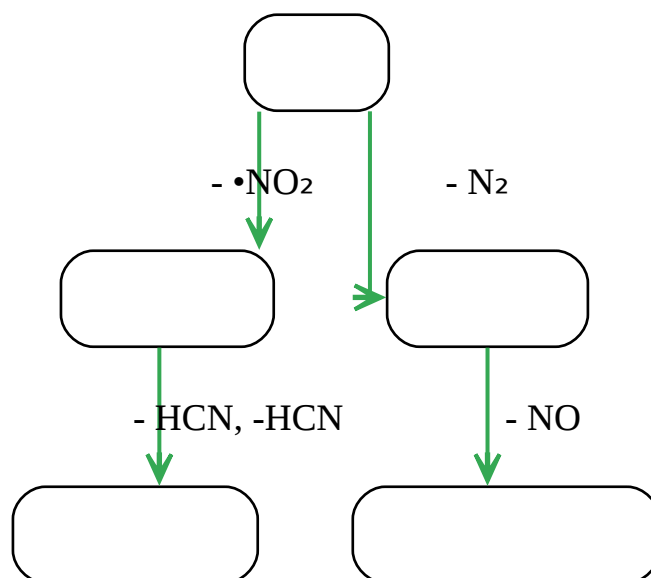

[Click to download full resolution via product page](#)

Caption: Proposed EI fragmentation of 1-(3-nitrophenyl)-1,2,3-triazole.

Fragmentation of 1-(4-Nitrophenyl)-1,2,3-triazole

Similar to the meta isomer, the para isomer's fragmentation is expected to be characterized by losses from both the nitrophenyl and triazole rings without the influence of an ortho effect. The relative abundances of the fragment ions may differ slightly from the meta isomer, which can be a key differentiating feature.

The fragmentation of a related compound, 1-benzyl-4-(4-nitrophenyl)-1H-1,2,3-triazole, shows losses of H, N₂, and NO₂, supporting the proposed fragmentation of the simpler 1-(4-nitrophenyl)-1,2,3-triazole.^[1]

Proposed EI Fragmentation Pathway of 1-(4-Nitrophenyl)-1,2,3-triazole

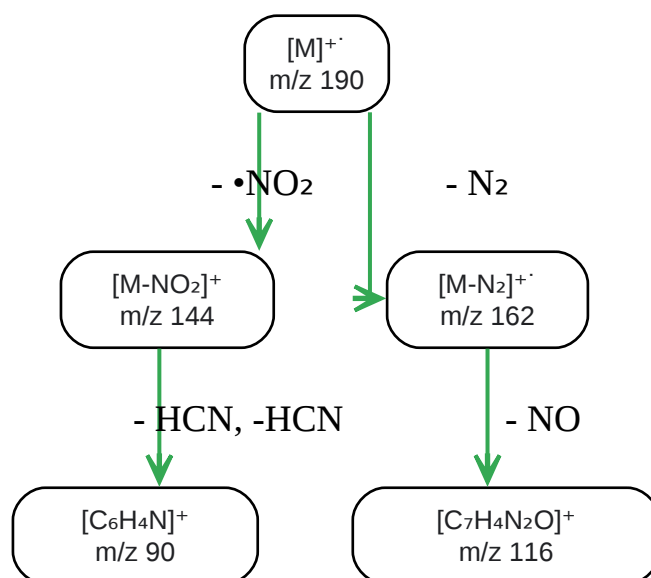

[Click to download full resolution via product page](#)

Caption: Proposed EI fragmentation of 1-(4-nitrophenyl)-1,2,3-triazole.

Comparison of Key Fragment Ions Under EI-MS

The table below summarizes the expected key fragment ions for the three isomers under electron ionization. The presence and relative intensity of these ions can be used for their differentiation.

m/z	Proposed Ion	1-(2-nitrophenyl)-1,2,3-triazole	1-(3-nitrophenyl)-1,2,3-triazole	1-(4-nitrophenyl)-1,2,3-triazole
190	[M] ^{+•}	Present	Present	Present
173	[M-OH] ⁺	Characteristic	Absent	Absent
162	[M-N ₂] ^{+•}	Present	Present	Present
144	[M-NO ₂] ⁺	Present	Present	Present
116	[C ₇ H ₄ N ₂ O] ⁺	Present	Present	Present
90	[C ₆ H ₄ N] ⁺	Present	Present	Present

Note: The relative intensities of the common fragments are expected to vary between the meta and para isomers.

Electrospray Ionization (ESI) and Tandem MS (MS/MS)

Under typical ESI conditions, all three isomers are expected to primarily form the protonated molecule $[M+H]^+$ at m/z 191. In the absence of in-source fragmentation, the ESI mass spectra of the isomers will be indistinguishable.

To differentiate the isomers using ESI, tandem mass spectrometry (MS/MS) is required. By isolating the $[M+H]^+$ ion and subjecting it to collision-induced dissociation (CID), characteristic fragment ions can be generated.

The fragmentation of the protonated molecule is expected to be less extensive than under EI. Key fragmentations would likely involve the loss of N_2 from the protonated triazole ring and potentially losses related to the nitro group, though these may require higher collision energies. The ortho isomer might again exhibit unique fragmentation due to proton-catalyzed interactions between the nitro and triazole groups.

Experimental Protocols

Gas Chromatography-Mass Spectrometry (GC-MS) for EI Analysis

- Sample Preparation: Dissolve the nitrophenyl triazole isomer in a suitable solvent (e.g., methanol, acetonitrile) to a concentration of 1 mg/mL. Dilute to a final concentration of 1-10 $\mu\text{g/mL}$ for injection.
- GC Conditions:
 - Inlet Temperature: 250 °C
 - Injection Volume: 1 μL (split or splitless, depending on concentration)
 - Carrier Gas: Helium at a constant flow rate of 1 mL/min

- Oven Program: Start at 100 °C, hold for 1 min, ramp to 280 °C at 15 °C/min, and hold for 5 min.
- MS Conditions (EI):
 - Ion Source Temperature: 230 °C
 - Electron Energy: 70 eV
 - Mass Range: m/z 40-300

Liquid Chromatography-Mass Spectrometry (LC-MS) for ESI Analysis

- Sample Preparation: Dissolve the nitrophenyl triazole isomer in the mobile phase or a compatible solvent to a concentration of 1 mg/mL. Dilute to a final concentration of 1-10 µg/mL for injection.
- LC Conditions:
 - Column: C18 reversed-phase column (e.g., 2.1 x 50 mm, 1.8 µm)
 - Mobile Phase A: Water with 0.1% formic acid
 - Mobile Phase B: Acetonitrile with 0.1% formic acid
 - Gradient: Start with 10% B, ramp to 95% B over 5 minutes, hold for 2 minutes, and then return to initial conditions.
 - Flow Rate: 0.3 mL/min
 - Column Temperature: 40 °C
- MS Conditions (ESI):
 - Ionization Mode: Positive
 - Capillary Voltage: 3.5 kV

- Source Temperature: 120 °C
- Desolvation Temperature: 350 °C
- Desolvation Gas Flow: 600 L/hr
- Cone Voltage: 30 V
- Mass Range: m/z 50-300
- For MS/MS: Isolate the precursor ion at m/z 191 and apply a collision energy of 10-30 eV.

Conclusion

The differentiation of nitrophenyl triazole isomers by mass spectrometry is highly dependent on the chosen ionization technique. Electron ionization provides rich fragmentation patterns that allow for clear distinction, with the ortho isomer exhibiting a characteristic "ortho effect."

Electrospray ionization, when coupled with tandem mass spectrometry, can also be a powerful tool for isomer differentiation. The insights and protocols provided in this guide offer a robust framework for the accurate identification and characterization of these important compounds in various research and development settings.

References

- Mass spectra of 1-benzyl-4-(substituted phenyl)-1H-1,2,3-triazoles. RSC Advances, 2015, 5, 103513-103524. [[Link](#)]

Need Custom Synthesis?

BenchChem offers custom synthesis for rare earth carbides and specific isotopic labeling.

Email: info@benchchem.com or [Request Quote Online](#).

Sources

- [1. rsc.org \[rsc.org\]](https://www.rsc.org)
- [To cite this document: BenchChem. \[A Comparative Guide to the Mass Spectrometry Fragmentation Patterns of Nitrophenyl Triazoles\]. BenchChem, \[2026\]. \[Online PDF\].](#)

Available at: [<https://www.benchchem.com/product/b3054860/docs#a-comparative-guide-to-the-mass-spectrometry-fragmentation-patterns-of-nitrophenyl-triazoles>]

Disclaimer & Data Validity:

The information provided in this document is for Research Use Only (RUO) and is strictly not intended for diagnostic or therapeutic procedures. While BenchChem strives to provide accurate protocols, we make no warranties, express or implied, regarding the fitness of this product for every specific experimental setup.

Technical Support: The protocols provided are for reference purposes. Unsure if this reagent suits your experiment?

Need Industrial/Bulk Grade? [Request Custom Synthesis Quote](#)

BenchChem

Our mission is to be the trusted global source of essential and advanced chemicals, empowering scientists and researchers to drive progress in science and industry.

Contact

Address: 3281 E Guasti Rd
Ontario, CA 91761, United States
Phone: (601) 213-4426
Email: info@benchchem.com

[Contact our Ph.D. Support Team for a compatibility check](#)