

Technical Guide: Solubility & Stability Profile of 2-Methoxy-5-Nitrophenyl Acetate

Author: BenchChem Technical Support Team. **Date:** April 2026

Compound of Interest

Compound Name:	2-methoxy-5-nitrophenyl acetate
CAS No.:	53606-41-0
Cat. No.:	B3053417

[Get Quote](#)

Executive Summary

2-Methoxy-5-nitrophenyl acetate (CAS: 53606-41-0), also known as 5-nitroguaiacol acetate, is a specialized chromogenic ester used primarily as a substrate for characterizing esterase and lipase activity. Its utility hinges on a precise solubility profile: it must be dissolved in organic solvents to form stable stock solutions, yet remain soluble enough in aqueous buffers (upon dilution) to interact with enzymes without precipitating.

This guide provides a definitive analysis of its solubility in key organic solvents, the mechanistic basis for these interactions, and validated protocols for stock preparation and solubility determination.

Physicochemical Identity

Understanding the molecule's structure is prerequisite to predicting its solvent behavior. The compound features a hydrophobic phenyl ring substituted with a nitro group (electron-withdrawing), a methoxy group (electron-donating), and an acetate ester (hydrolytically labile).

Property	Detail
IUPAC Name	(2-Methoxy-5-nitrophenyl) acetate
CAS Number	53606-41-0
Molecular Formula	C ₉ H ₉ NO ₅
Molecular Weight	211.17 g/mol
Physical State	Yellow crystalline solid
Melting Point	~99–101 °C
LogP (Predicted)	~1.3 – 1.6 (Moderate Lipophilicity)
Key Functional Groups	Nitro (-NO ₂), Methoxy (-OCH ₃), Ester (-OCOCH ₃)

Solubility Profile in Organic Solvents[5]

The solubility of **2-methoxy-5-nitrophenyl acetate** is governed by dipole-dipole interactions and the ability of solvents to accept hydrogen bonds (though the molecule itself is a poor H-bond donor).

Solvent Compatibility Table

Data synthesized from structural analogs (e.g., p-nitrophenyl acetate) and experimental application protocols.

Solvent Class	Specific Solvent	Solubility Rating	Estimated Limit (25°C)	Application Context
Aprotic Polar	DMSO (Dimethyl sulfoxide)	Excellent	> 50 mM (~10 mg/mL)	Preferred for stock solutions. High boiling point, miscible with water.
Aprotic Polar	DMF (Dimethylformamide)	Excellent	> 50 mM	Alternative to DMSO; potential enzyme inhibition risks.
Protic Polar	Ethanol (Absolute)	Good	~100 mg/mL (with heat)*	Common for synthesis; risk of transesterification if not dry.
Protic Polar	Methanol	Good	~50–80 mg/mL	Good for chromatography; high evaporation rate.
Non-Polar	Dichloromethane (DCM)	High	> 100 mg/mL	Extraction and synthesis; not suitable for biological assays.
Aqueous	Water / PBS	Poor	< 1 mM	Unstable. Rapid hydrolysis. Requires organic co-solvent (e.g., 5% DMSO).

*Note: Heating may be required to achieve saturation, but prolonged heat promotes degradation.

Mechanistic Insight

- DMSO/DMF: The nitro group creates a strong dipole moment, making the molecule highly soluble in polar aprotic solvents like DMSO. This is the industry standard for biological assays because DMSO prevents the "crashing out" of the compound upon dilution into aqueous buffers.
- Alcohols (EtOH/MeOH): While soluble, these solvents pose a stability risk. Traces of water or base in alcohols can catalyze transesterification or hydrolysis, degrading the acetate ester into 2-methoxy-5-nitrophenol (the yellow hydrolysis product) before the assay begins.

Stability & Hydrolysis Risks

The acetate ester bond is the "Achilles' heel" of this molecule. It is designed to be cleaved by enzymes, but it is also susceptible to spontaneous chemical hydrolysis.

- The "Yellowing" Indicator: The hydrolysis product, 2-methoxy-5-nitrophenol (5-nitroguaiacol), is yellow in alkaline solution (absorbance max ~405 nm). If your stock solution turns yellow, significant degradation has occurred.
- Water Sensitivity: Even atmospheric moisture absorbed by hygroscopic solvents (like DMSO) can trigger hydrolysis over weeks.

Visualization: Degradation Pathway

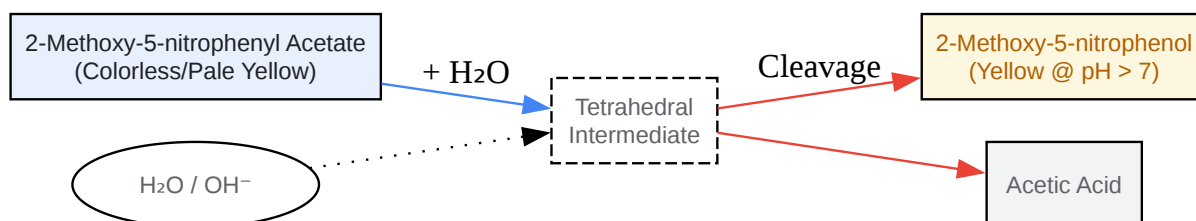

Fig 1. Spontaneous Hydrolysis Pathway yielding the chromogenic product.

[Click to download full resolution via product page](#)

Experimental Protocols

Protocol A: Preparation of Stable Stock Solutions

Objective: Create a 50 mM stock solution for long-term storage.

- Solvent Selection: Use Anhydrous DMSO (Grade $\geq 99.9\%$, water < 50 ppm). Avoid ethanol for long-term storage to prevent transesterification.
- Weighing: Accurately weigh 10.6 mg of **2-methoxy-5-nitrophenyl acetate** into a sterile, amber microcentrifuge tube (protect from light).
- Dissolution: Add 1.0 mL of Anhydrous DMSO. Vortex vigorously for 30–60 seconds until no crystals remain.
 - Troubleshooting: If crystals persist, sonicate for 2 minutes at room temperature. Do not heat above 37°C .
- Storage: Aliquot into small volumes (e.g., 50 μL) to avoid freeze-thaw cycles. Store at -20°C with desiccant.
- Validation: Before use, dilute 1:100 into pH 7.4 buffer. The solution should be clear. If it turns bright yellow immediately, the stock has degraded.

Protocol B: Determination of Saturation Solubility (Self-Validating)

Objective: Determine the exact solubility limit in a specific solvent (e.g., Toluene) for synthesis optimization.

- Excess Addition: Add solid compound to 2 mL of the target solvent until a visible solid precipitate remains (supersaturation).
- Equilibration: Shake at a constant temperature (e.g., 25°C) for 24 hours.
- Filtration: Filter the supernatant through a 0.45 μm PTFE syringe filter (nylon filters may bind the compound).
- Quantification (UV-Vis):
 - Dilute the filtrate 1:1000 in Methanol.

- Measure Absorbance at ~300–320 nm (Ester peak) and ~405 nm (Phenol peak).
- Self-Check: If the 405 nm peak is significant, hydrolysis occurred during the experiment (invalidating the result for "intact" ester solubility).

Visualization: Solubility Workflow

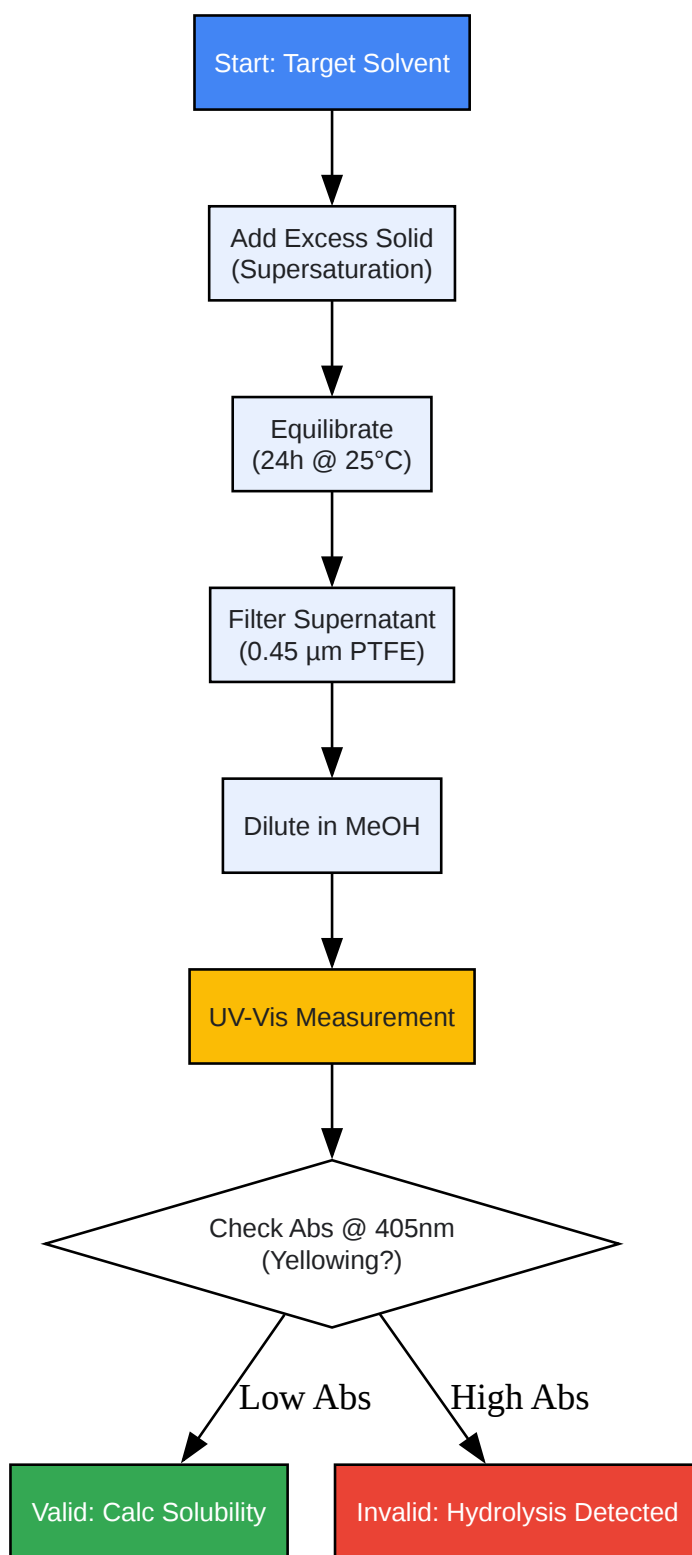

Fig 2. Self-Validating Solubility Determination Workflow

[Click to download full resolution via product page](#)

Applications in Drug Development

The primary value of **2-methoxy-5-nitrophenyl acetate** lies in its role as a surrogate substrate.

- **Esterase Assays:** Used to screen for carboxylesterase activity in liver microsomes. The release of 2-methoxy-5-nitrophenol is monitored at 405 nm (alkaline pH) or 347 nm (isosbestic point, pH independent).
- **Prodrug Modeling:** The compound mimics the physicochemical properties of phenyl ester prodrugs. Its solubility data in Octanol/Water (LogP) helps predict passive diffusion rates across membranes.
- **Solvent Effects on Kinetics:** When performing assays, keep the final organic solvent concentration (DMSO) below 2% (v/v). Higher concentrations can inhibit enzyme activity or cause the substrate to precipitate, leading to false negatives.

References

- National Center for Biotechnology Information (NCBI). (2025). PubChem Compound Summary for CID 69471, 2-Methoxy-5-nitrophenol. Retrieved from [[Link](#)]
- NIST Mass Spectrometry Data Center. (2025).[1] 2-Methoxy-5-nitrophenol, acetate Mass Spectrum. NIST Chemistry WebBook. Retrieved from [[Link](#)]
- ResearchGate. (2016). Accurately determining esterase activity via the isosbestic point of p-nitrophenol. Retrieved from [[Link](#)]

Need Custom Synthesis?

BenchChem offers custom synthesis for rare earth carbides and specific isotopic labeling.

Email: info@benchchem.com or [Request Quote Online](#).

Sources

- [1. 2-Methoxy-5-nitrophenol | C7H7NO4 | CID 69471 - PubChem \[pubchem.ncbi.nlm.nih.gov\]](#)

- To cite this document: BenchChem. [Technical Guide: Solubility & Stability Profile of 2-Methoxy-5-Nitrophenyl Acetate]. BenchChem, [2026]. [Online PDF]. Available at: [<https://www.benchchem.com/product/b3053417/docs#technical-guide-solubility-stability-profile-of-2-methoxy-5-nitrophenyl-acetate>]

Disclaimer & Data Validity:

The information provided in this document is for Research Use Only (RUO) and is strictly not intended for diagnostic or therapeutic procedures. While BenchChem strives to provide accurate protocols, we make no warranties, express or implied, regarding the fitness of this product for every specific experimental setup.

Technical Support: The protocols provided are for reference purposes. Unsure if this reagent suits your experiment?

Need Industrial/Bulk Grade? [Request Custom Synthesis Quote](#)

BenchChem

Our mission is to be the trusted global source of essential and advanced chemicals, empowering scientists and researchers to drive progress in science and industry.

Contact

Address: 3281 E Guasti Rd
Ontario, CA 91761, United States
Phone: (601) 213-4426
Email: info@benchchem.com

[Contact our Ph.D. Support Team for a compatibility check](#)