

Technical Support Center: Improving the Bioavailability of CD80-IN-3

Author: BenchChem Technical Support Team. **Date:** April 2026

Compound of Interest

Compound Name:	CD80-IN-3
CAS No.:	486449-65-4
Cat. No.:	B3052932

[Get Quote](#)

This technical support center provides troubleshooting guides and frequently asked questions (FAQs) to assist researchers, scientists, and drug development professionals in overcoming potential challenges related to the bioavailability of **CD80-IN-3**, a potent inhibitor of the CD80/CD28 interaction.

Frequently Asked Questions (FAQs)

Q1: What is **CD80-IN-3** and what is its mechanism of action?

CD80-IN-3 is a small molecule inhibitor that potently targets the CD80 protein, disrupting its interaction with the CD28 receptor.[1] The CD80-CD28 interaction is a critical co-stimulatory signal required for the full activation of T-cells.[2][3][4][5] By blocking this pathway, **CD80-IN-3** can modulate T-cell responses, making it a valuable tool for research in immunology and for the development of therapies for autoimmune diseases and cancer.[3][6]

Q2: What are the potential reasons for poor oral bioavailability of a small molecule inhibitor like **CD80-IN-3**?

Poor oral bioavailability of small molecule inhibitors is often attributed to several factors:

- **Low Aqueous Solubility:** The compound may not dissolve readily in the gastrointestinal fluids, which is a prerequisite for absorption.[7][8][9][10]
- **Poor Intestinal Permeability:** The molecule may have difficulty crossing the intestinal epithelial barrier to enter the bloodstream.[9]
- **First-Pass Metabolism:** The compound may be extensively metabolized in the liver before it reaches systemic circulation.[11]
- **Efflux by Transporters:** The molecule might be actively pumped back into the intestinal lumen by efflux transporters like P-glycoprotein (P-gp).[11]

While specific data for **CD80-IN-3** is not publicly available, researchers should consider these common challenges. The in vivo formulation suggestion for **CD80-IN-3**, which includes DMSO, PEG300, and Tween 80, suggests that it may have poor aqueous solubility.[1]

Q3: What are the initial steps to assess the potential bioavailability of **CD80-IN-3** in the laboratory?

Before proceeding to in vivo studies, several in vitro assays can provide valuable insights into the potential bioavailability of **CD80-IN-3**:

- **Solubility Assessment:** Determine the solubility of **CD80-IN-3** in physiologically relevant buffers (e.g., pH 1.2, 4.5, and 6.8) to simulate the conditions of the gastrointestinal tract.[12]
- **Permeability Assays:** Use in vitro models like the Parallel Artificial Membrane Permeability Assay (PAMPA) or Caco-2 cell monolayers to predict the passive diffusion and active transport of the compound across the intestinal barrier.[12][13]
- **In Vitro Dissolution Testing:** Evaluate the dissolution rate of different formulations of **CD80-IN-3** to understand how quickly the drug becomes available for absorption.[14][15]

Troubleshooting Guides

Problem 1: Low and variable oral exposure of **CD80-IN-3** in preclinical animal studies.

Possible Causes & Troubleshooting Steps:

Possible Cause	Troubleshooting & Optimization
Poor Aqueous Solubility	Formulate CD80-IN-3 using techniques known to enhance the solubility of poorly soluble drugs. [7] [10] [11] [16] [17] [18] [19] [20] See Protocol 1: Formulation Development for Poorly Soluble Compounds.
Low Intestinal Permeability	Conduct a Caco-2 bidirectional transport study to determine the efflux ratio and investigate if CD80-IN-3 is a substrate for efflux transporters like P-gp. If it is, consider co-administration with a known P-gp inhibitor in preclinical models to confirm this mechanism.
High First-Pass Metabolism	Perform in vitro metabolism studies using liver microsomes or hepatocytes to assess the metabolic stability of CD80-IN-3. If metabolism is high, medicinal chemistry efforts may be needed to design more stable analogs.
Positive Food Effect	A significant "positive food effect" can occur where the presence of dietary fats increases the solubilization and absorption of a lipophilic drug. To ensure consistent results, it may be necessary to standardize administration with or without food. Conduct a formal food-effect study in a relevant animal model, comparing pharmacokinetics in fasted and fed states. [21]

Problem 2: Difficulty in preparing a stable and consistent formulation for in vivo studies.

Possible Causes & Troubleshooting Steps:

Possible Cause	Troubleshooting & Optimization
Drug Precipitation upon Dilution	The use of co-solvents can lead to drug precipitation when the formulation is diluted in aqueous environments.[8] Evaluate alternative formulation strategies such as solid dispersions, nanosuspensions, or lipid-based formulations which can improve stability upon dilution.[7][17][18]
Inconsistent Particle Size	For suspension formulations, inconsistent particle size can lead to variable dissolution and absorption.[16][18] Employ robust particle size reduction techniques like micronization or nanomilling and consistently monitor particle size distribution.
Chemical Instability	Assess the stability of CD80-IN-3 in the chosen formulation vehicle under storage and experimental conditions.

Experimental Protocols

Protocol 1: Formulation Development for Poorly Soluble Compounds

This protocol outlines common strategies to improve the solubility and dissolution rate of compounds like **CD80-IN-3**.

- Particle Size Reduction:
 - Micronization: Use techniques like air-jet milling to reduce the particle size of the drug substance to the micron range (2–5 μm), thereby increasing the surface area for dissolution.[17]
 - Nanonization: For a more significant increase in surface area, employ methods like wet milling or high-pressure homogenization to create a nanosuspension with particle sizes typically below 200 nm.[8][18]

- Solid Dispersions:
 - Prepare a solid dispersion by dissolving **CD80-IN-3** and a hydrophilic polymer carrier (e.g., PVP, HPMC) in a common solvent, followed by solvent evaporation or spray drying.[7][17] This results in the drug being dispersed in an amorphous state within the polymer matrix, enhancing solubility.[10]
- Lipid-Based Formulations (e.g., Self-Emulsifying Drug Delivery Systems - SEDDS):
 - Screen for the solubility of **CD80-IN-3** in various oils, surfactants, and co-solvents.
 - Develop a SEDDS formulation by mixing the drug with an optimal ratio of oil, surfactant, and co-solvent. This formulation will spontaneously form a microemulsion upon contact with gastrointestinal fluids, enhancing drug solubilization.[7][16][17][20]

Protocol 2: In Vivo Bioavailability Assessment in Animal Models

This protocol describes a typical crossover study design to determine the oral bioavailability of a **CD80-IN-3** formulation.

- Animal Model Selection: Choose a suitable animal model (e.g., rats, mice) based on the research question and metabolic profile.[22]
- Study Design: Employ a crossover design where the same group of animals receives both an intravenous (IV) and an oral (PO) dose of **CD80-IN-3**, separated by a washout period. The IV dose serves as the 100% bioavailability reference.[22]
- Dose Administration:
 - IV Administration: Administer a known dose of a solubilized formulation of **CD80-IN-3** intravenously.
 - Oral Administration: Administer a known dose of the test formulation of **CD80-IN-3** orally via gavage.
- Blood Sampling: Collect blood samples at predetermined time points after each administration.[22]

- Sample Analysis: Analyze the plasma concentrations of **CD80-IN-3** using a validated analytical method, such as LC-MS/MS.[23]
- Pharmacokinetic Analysis:
 - Calculate the Area Under the Curve (AUC) for both the oral and IV routes.
 - Calculate the absolute oral bioavailability (F%) using the following formula: $F (\%) = (AUC_{oral} / AUC_{IV}) * (Dose_{IV} / Dose_{oral}) * 100$ [22]

Data Presentation

Table 1: Hypothetical Solubility Data for **CD80-IN-3** in Different Media

Medium	pH	Solubility (µg/mL)
Simulated Gastric Fluid (SGF)	1.2	< 1
Simulated Intestinal Fluid (SIF)	6.8	< 5
Water	7.0	< 0.5
20% PEG400 in Water	7.0	50
10% Tween 80 in Water	7.0	25

Table 2: Hypothetical Pharmacokinetic Parameters of Different **CD80-IN-3** Formulations in Rats

Formulation	Dose (mg/kg)	Route	Cmax (ng/mL)	Tmax (h)	AUC (ng*h/mL)	Bioavailability (%)
Aqueous Suspension	10	PO	50	2	200	5
Nanosuspension	10	PO	250	1	1200	30
Solid Dispersion	10	PO	400	1	2000	50
IV Solution	2	IV	1000	0.1	4000	100

Visualizations

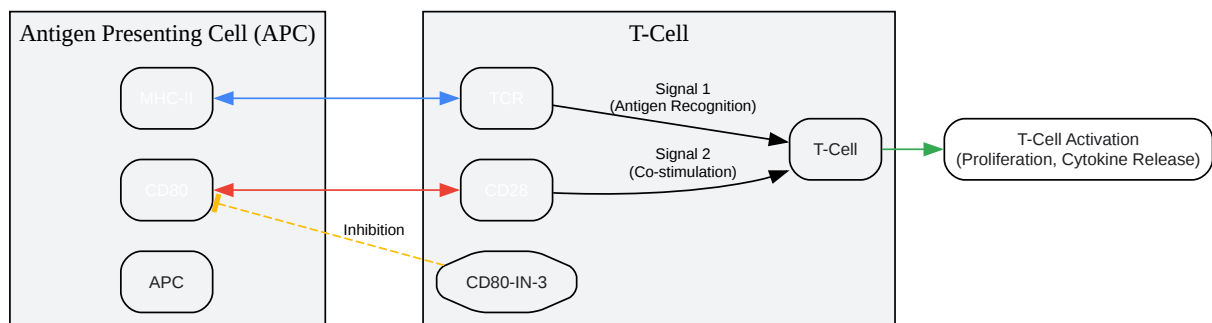

[Click to download full resolution via product page](#)

Caption: CD80-CD28 signaling pathway and the inhibitory action of **CD80-IN-3**.

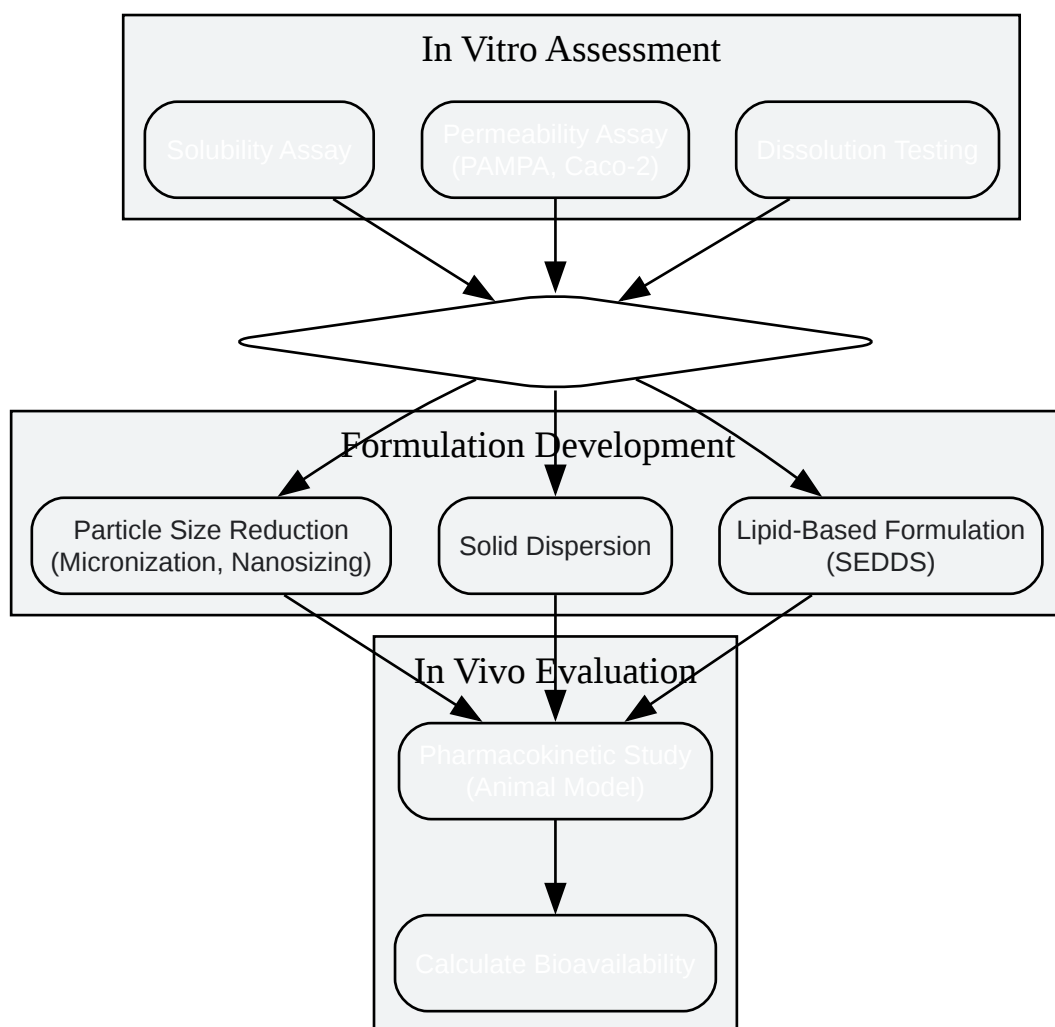

[Click to download full resolution via product page](#)

Caption: Experimental workflow for improving and assessing the bioavailability of **CD80-IN-3**.

Need Custom Synthesis?

BenchChem offers custom synthesis for rare earth carbides and specific isotopic labeling.

Email: info@benchchem.com or [Request Quote Online](#).

References

- 1. [CD80-IN-3 | Bombesin Receptor | TargetMol \[targetmol.com\]](#)
- 2. [CD80 - Wikipedia \[en.wikipedia.org\]](#)

- [3. CD28 and CD80/CD86 Pathway - Creative Biolabs \[immune-checkpoint.creative-biolabs.com\]](#)
- [4. CD80 on Human T Cells Is Associated With FoxP3 Expression and Supports Treg Homeostasis - PMC \[pmc.ncbi.nlm.nih.gov\]](#)
- [5. CD80-Fc fusion protein as a potential cancer immunotherapy strategy - PMC \[pmc.ncbi.nlm.nih.gov\]](#)
- [6. Research progress of CD80 in the development of immunotherapy drugs - PMC \[pmc.ncbi.nlm.nih.gov\]](#)
- [7. hilarispublisher.com \[hilarispublisher.com\]](#)
- [8. sphinxsai.com \[sphinxsai.com\]](#)
- [9. Bioavailability Enhancement Techniques for Poorly Aqueous Soluble Drugs and Therapeutics - PMC \[pmc.ncbi.nlm.nih.gov\]](#)
- [10. mdpi.com \[mdpi.com\]](#)
- [11. researchgate.net \[researchgate.net\]](#)
- [12. Recent Options and Techniques to Assess Improved Bioavailability: In Vitro and Ex Vivo Methods - PMC \[pmc.ncbi.nlm.nih.gov\]](#)
- [13. Combined Methodologies for Determining In Vitro Bioavailability of Drugs and Prediction of In Vivo Bioequivalence From Pharmaceutical Oral Formulations - PMC \[pmc.ncbi.nlm.nih.gov\]](#)
- [14. americanpharmaceuticalreview.com \[americanpharmaceuticalreview.com\]](#)
- [15. merieuxnutrisciences.com \[merieuxnutrisciences.com\]](#)
- [16. Enhancing the Bioavailability of Poorly Soluble Compounds: Strategies for Formulation Optimization in Preclinical Studies - WuXi AppTec DMPK \[dmpk.service.wuxiapptec.com\]](#)
- [17. Formulation Strategies to Improve the Bioavailability of Poorly Absorbed Drugs with Special Emphasis on Self-Emulsifying Systems - PMC \[pmc.ncbi.nlm.nih.gov\]](#)
- [18. mdpi.com \[mdpi.com\]](#)
- [19. drughunter.com \[drughunter.com\]](#)
- [20. Overcoming Challenges in Small-Molecule Drug Bioavailability: A Review of Key Factors and Approaches - PMC \[pmc.ncbi.nlm.nih.gov\]](#)
- [21. benchchem.com \[benchchem.com\]](#)
- [22. researchgate.net \[researchgate.net\]](#)

- [23. Preclinical Bioavailability Assessment of a Poorly Water-Soluble Drug, HGR4113, Using a Stable Isotope Tracer - PMC \[pmc.ncbi.nlm.nih.gov\]](#)
- To cite this document: BenchChem. [Technical Support Center: Improving the Bioavailability of CD80-IN-3]. BenchChem, [2026]. [Online PDF]. Available at: [\[https://www.benchchem.com/product/b3052932/docs#technical-support-center-improving-the-bioavailability-of-cd80-in-3\]](https://www.benchchem.com/product/b3052932/docs#technical-support-center-improving-the-bioavailability-of-cd80-in-3)

Disclaimer & Data Validity:

The information provided in this document is for Research Use Only (RUO) and is strictly not intended for diagnostic or therapeutic procedures. While BenchChem strives to provide accurate protocols, we make no warranties, express or implied, regarding the fitness of this product for every specific experimental setup.

Technical Support: The protocols provided are for reference purposes. Unsure if this reagent suits your experiment?

Need Industrial/Bulk Grade? [Request Custom Synthesis Quote](#)

BenchChem

Our mission is to be the trusted global source of essential and advanced chemicals, empowering scientists and researchers to drive progress in science and industry.

Contact

Address: 3281 E Guasti Rd
Ontario, CA 91761, United States
Phone: (601) 213-4426
Email: info@benchchem.com

[Contact our Ph.D. Support Team for a compatibility check](#)