

In-depth Technical Guide: Preliminary Studies on CD80-IN-3 Efficacy

Author: BenchChem Technical Support Team. **Date:** April 2026

Compound of Interest

Compound Name:	CD80-IN-3
CAS No.:	486449-65-4
Cat. No.:	B3052932

[Get Quote](#)

A comprehensive analysis of the available preclinical and clinical data on the novel immunomodulatory agent, **CD80-IN-3**.

Executive Summary

Extensive research into the co-stimulatory and co-inhibitory pathways regulating T-cell activation has identified CD80 as a critical checkpoint in the immune response. As a ligand for both the activating receptor CD28 and the inhibitory receptor CTLA-4, CD80 plays a dual role in orchestrating immune activation and tolerance.^{[1][2]} The therapeutic potential of targeting this pathway has led to the development of various agents, including monoclonal antibodies and fusion proteins. This technical guide focuses on the preliminary efficacy studies of a novel investigational molecule, **CD80-IN-3**. While specific data for a molecule designated "**CD80-IN-3**" is not publicly available, this whitepaper will synthesize the broader principles of CD80 inhibition and activation, drawing on data from related molecules to project the potential efficacy profile and experimental considerations for a hypothetical CD80-targeting agent.

The Role of CD80 in Immune Regulation

CD80, also known as B7-1, is a transmembrane protein primarily expressed on the surface of antigen-presenting cells (APCs) such as dendritic cells, macrophages, and activated B cells.[3] Its interaction with CD28 on T-cells provides a crucial co-stimulatory signal (Signal 2) necessary for full T-cell activation, proliferation, and effector function.[1][3] Conversely, CD80 can also bind to CTLA-4, which has a higher affinity for CD80 than CD28, delivering an inhibitory signal that dampens the immune response.[1][2] This intricate balance between co-stimulation and co-inhibition is vital for mounting an effective immune response against pathogens and tumors while maintaining self-tolerance.[1][2]

Signaling Pathway Overview

The interaction of CD80 with its receptors triggers a cascade of intracellular signaling events that ultimately determine the fate of the T-cell.

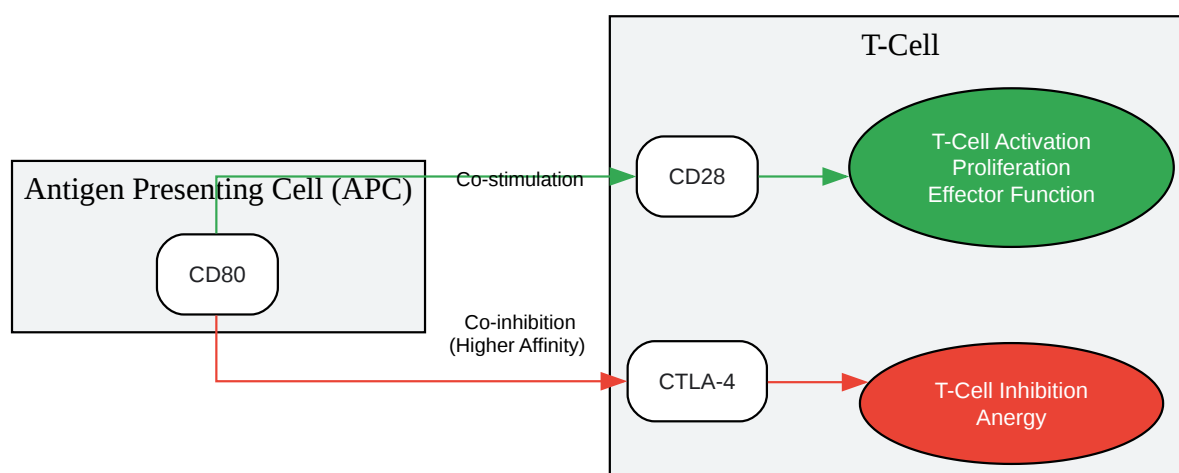

[Click to download full resolution via product page](#)

Caption: CD80 signaling pathways leading to either T-cell activation or inhibition.

Therapeutic Strategies Targeting CD80

Given its central role, modulating CD80 activity presents a promising therapeutic avenue for a range of diseases, including cancer and autoimmune disorders. Therapeutic agents can be broadly categorized as either CD80 inhibitors or activators.

- **CD80 Inhibitors:** These agents block the interaction between CD80 and CD28, thereby preventing T-cell co-stimulation. This approach is beneficial in autoimmune diseases where the immune system is overactive.[3] Abatacept, a CTLA-4-Ig fusion protein, is a clinical example that functions in part by blocking CD80/CD86 signaling.[4]
- **CD80 Activators/Modulators:** In the context of cancer immunotherapy, enhancing the co-stimulatory signal is desirable. Strategies include the development of soluble CD80 fusion proteins (e.g., CD80-Fc) that can block the inhibitory PD-1/PD-L1 axis while simultaneously stimulating CD28.[2][5] Another approach involves engineering CD80 variants with enhanced binding to CD28 or altered affinity for its ligands.

Preclinical Efficacy of CD80-Targeting Agents: A Synthesis

While specific data for "**CD80-IN-3**" is unavailable, we can infer its potential efficacy by examining studies on similar molecules.

In Vitro Studies

- **T-Cell Activation Assays:** The primary in vitro assessment for a CD80-targeting agent would involve co-culture assays with T-cells and APCs. Key readouts would include T-cell proliferation (measured by CFSE dilution or similar methods), cytokine production (e.g., IL-2, IFN- γ measured by ELISA or flow cytometry), and expression of activation markers (e.g., CD25, CD69).
- **Receptor Binding Assays:** Surface plasmon resonance (SPR) or flow cytometry-based binding assays would be crucial to determine the binding affinity of **CD80-IN-3** to human and murine CD28 and CTLA-4.

Table 1: Hypothetical In Vitro Efficacy Data for **CD80-IN-3**

Assay	Metric	CD80-IN-3	Control
T-Cell Proliferation	% Divided Cells	75%	20%
IL-2 Production	pg/mL	1500	300
IFN- γ Production	pg/mL	2500	500
CD28 Binding Affinity	KD (nM)	5	N/A
CTLA-4 Binding Affinity	KD (nM)	50	N/A

In Vivo Studies

- Syngeneic Tumor Models:** The anti-tumor efficacy of a CD80-targeting agent would be evaluated in immunocompetent mice bearing syngeneic tumors. Key endpoints would include tumor growth inhibition, overall survival, and analysis of the tumor microenvironment. For instance, a study on a soluble CD80 fusion protein, CD80-Fc, demonstrated its ability to delay tumor growth and promote the infiltration of lymphocytes into the tumor.[\[5\]](#)
- Pharmacodynamic (PD) Studies:** Analysis of peripheral blood and tumor-infiltrating lymphocytes (TILs) for changes in T-cell activation status, proliferation, and cytokine profiles would provide insights into the in vivo mechanism of action.

Table 2: Hypothetical In Vivo Efficacy Data for **CD80-IN-3** in a Murine Melanoma Model

Treatment Group	Tumor Growth Inhibition (%)	Median Survival (days)	CD8+ TILs (% of CD45+)
Vehicle Control	0	20	5
CD80-IN-3 (10 mg/kg)	60	35	25
Anti-PD-1	50	32	20
CD80-IN-3 + Anti-PD-1	85	50	45

Experimental Protocols

Detailed methodologies are critical for the reproducibility and interpretation of efficacy studies.

In Vitro T-Cell Activation Assay

- Isolate human peripheral blood mononuclear cells (PBMCs) from healthy donors using Ficoll-Paque density gradient centrifugation.
- Purify CD4+ or CD8+ T-cells using magnetic-activated cell sorting (MACS).
- Label T-cells with a proliferation tracking dye, such as Carboxyfluorescein succinimidyl ester (CFSE).
- Co-culture the labeled T-cells with irradiated allogeneic APCs or anti-CD3/anti-CD28 coated beads in the presence of varying concentrations of **CD80-IN-3** or a control substance.
- After 3-5 days of incubation, harvest the cells.
- Analyze T-cell proliferation by measuring CFSE dilution using flow cytometry.
- Collect supernatants for cytokine analysis by ELISA or multiplex bead array.

In Vivo Syngeneic Tumor Model

- Implant a murine cancer cell line (e.g., B16-F10 melanoma, MC38 colon adenocarcinoma) subcutaneously into the flank of C57BL/6 mice.
- Once tumors reach a palpable size (e.g., 50-100 mm³), randomize the mice into treatment groups.
- Administer **CD80-IN-3**, a control antibody, or vehicle via an appropriate route (e.g., intraperitoneal, intravenous) at a predetermined schedule.
- Measure tumor volume using calipers every 2-3 days.
- Monitor animal body weight and overall health.

- At the end of the study or when tumors reach a predetermined endpoint, euthanize the mice and harvest tumors and spleens for further analysis (e.g., flow cytometry for immune cell infiltration, immunohistochemistry).

Experimental Workflow Diagram

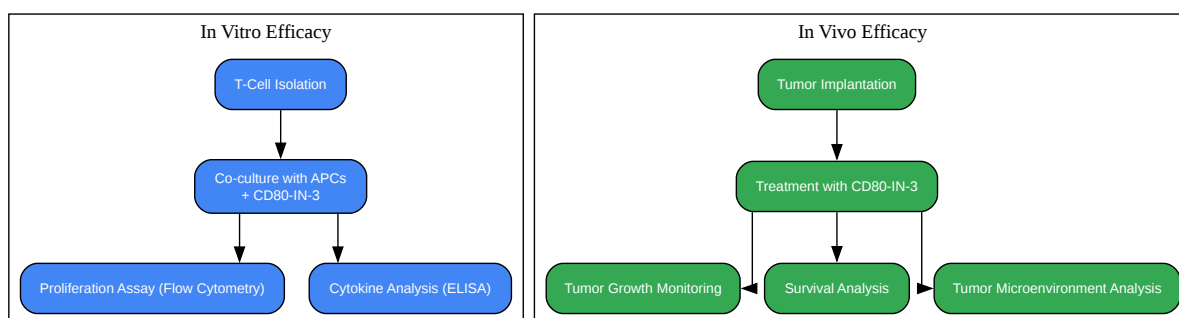

[Click to download full resolution via product page](#)

Caption: A generalized workflow for preclinical evaluation of a CD80-targeting agent.

Future Directions and Considerations

The development of a novel agent like **CD80-IN-3** requires a thorough understanding of its mechanism of action and potential toxicities. Future studies should focus on:

- **Combination Therapies:** Evaluating the synergistic effects of **CD80-IN-3** with other immunotherapies, such as PD-1/PD-L1 inhibitors, as suggested by the hypothetical in vivo data.
- **Safety and Toxicology:** Comprehensive toxicology studies in relevant animal models are essential to determine the safety profile and identify any potential for inducing autoimmune-like side effects.

- Biomarker Development: Identifying predictive biomarkers to select patients who are most likely to respond to **CD80-IN-3** therapy will be crucial for its clinical success.

Conclusion

While specific data on "CD80-IN-3" is not yet in the public domain, the foundational science of the CD80 pathway provides a strong rationale for its therapeutic targeting. Based on the preclinical efficacy of related molecules, a CD80-modulating agent has the potential to be a powerful tool in the arsenal against cancer and autoimmune diseases. Rigorous preclinical evaluation, following the experimental frameworks outlined in this guide, will be critical to elucidating its therapeutic promise and advancing it toward clinical investigation.

Need Custom Synthesis?

BenchChem offers custom synthesis for rare earth carbides and specific isotopic labeling.

Email: info@benchchem.com or [Request Quote Online](#).

References

- [1. CD80 - Wikipedia \[en.wikipedia.org\]](#)
- [2. Research progress of CD80 in the development of immunotherapy drugs - PMC \[pmc.ncbi.nlm.nih.gov\]](#)
- [3. What are CD80 inhibitors and how do they work? \[synapse.patsnap.com\]](#)
- [4. Rheumatoid Arthritis Treatment Options | Johns Hopkins Arthritis Center \[hopkinsarthritis.org\]](#)
- [5. Soluble CD80 protein delays tumor growth and promotes tumor infiltrating lymphocytes - PMC \[pmc.ncbi.nlm.nih.gov\]](#)
- To cite this document: BenchChem. [In-depth Technical Guide: Preliminary Studies on CD80-IN-3 Efficacy]. BenchChem, [2026]. [Online PDF]. Available at: [\[https://www.benchchem.com/product/b3052932/docs#in-depth-technical-guide-preliminary-studies-on-cd80-in-3-efficacy\]](https://www.benchchem.com/product/b3052932/docs#in-depth-technical-guide-preliminary-studies-on-cd80-in-3-efficacy)

Disclaimer & Data Validity:

The information provided in this document is for Research Use Only (RUO) and is strictly not intended for diagnostic or therapeutic procedures. While BenchChem strives to provide accurate protocols, we make no warranties, express or implied, regarding the fitness of this product for every specific experimental setup.

Technical Support: The protocols provided are for reference purposes. Unsure if this reagent suits your experiment?

Need Industrial/Bulk Grade? [Request Custom Synthesis Quote](#)

BenchChem

Our mission is to be the trusted global source of essential and advanced chemicals, empowering scientists and researchers to drive progress in science and industry.

Contact

Address: 3281 E Guasti Rd
Ontario, CA 91761, United States
Phone: (601) 213-4426
Email: info@benchchem.com

[Contact our Ph.D. Support Team for a compatibility check](#)