

An In-depth Technical Guide to Vinyl Cyclohexanecarboxylate (CAS 4840-76-0)

Author: BenchChem Technical Support Team. **Date:** April 2026

Compound of Interest

Compound Name: Vinyl cyclohexanecarboxylate

CAS No.: 4840-76-0

Cat. No.: B3052926

[Get Quote](#)

Foreword: Unveiling the Potential of a Versatile Monomer

In the dynamic landscape of polymer science and materials engineering, the demand for monomers that impart unique and desirable properties to resulting polymers is ever-present. **Vinyl cyclohexanecarboxylate** (VCHC), with its characteristic cycloaliphatic ester structure, represents a significant building block in the synthesis of advanced polymeric materials. This technical guide serves as a comprehensive resource for researchers, scientists, and drug development professionals, offering in-depth insights into the chemical properties, synthesis, reactivity, and applications of this versatile compound. Our exploration is grounded in established scientific principles and practical, field-proven knowledge, aiming to empower innovation in your research and development endeavors.

Core Chemical and Physical Identity

Vinyl cyclohexanecarboxylate, identified by the CAS number 4840-76-0, is a vinyl ester characterized by a cyclohexyl ring attached to a vinyl group through an ester linkage.^{[1][2]} This unique combination of a bulky, hydrophobic cycloaliphatic group and a reactive vinyl moiety

bestows upon it a distinct set of properties that are highly sought after in polymer manufacturing.

Physicochemical Properties at a Glance

A summary of the key physicochemical properties of **Vinyl Cyclohexanecarboxylate** is presented in Table 1 for easy reference. These parameters are critical for understanding its behavior in various chemical processes, from synthesis and purification to polymerization and formulation.

Property	Value	Reference
CAS Number	4840-76-0	[1]
Molecular Formula	C ₉ H ₁₄ O ₂	[1][2]
Molecular Weight	154.21 g/mol	[1]
IUPAC Name	Ethenyl cyclohexanecarboxylate	[1]
Synonyms	Cyclohexanecarboxylic acid, vinyl ester; VCHC	[1][2]
Appearance	Colorless liquid (presumed)	
Density	0.99 g/cm ³	[2]
Boiling Point	226 °C at 760 mmHg	[2]
Flash Point	85.1 °C	[2]
Vapor Pressure	0.0836 mmHg at 25 °C	[2]
Refractive Index	1.464	[2]

Synthesis and Manufacturing Pathways

The synthesis of **vinyl cyclohexanecarboxylate** primarily revolves around two established methodologies: the direct vinylation of cyclohexanecarboxylic acid with acetylene and the transvinylation reaction with a vinyl donor like vinyl acetate. The choice of synthetic route is often dictated by factors such as catalyst availability, reaction conditions, and desired purity.

Direct Vinylation with Acetylene

The industrial-scale production of many vinyl esters has historically relied on the reaction of carboxylic acids with acetylene.[3] This method, while efficient, requires careful handling of acetylene due to its explosive nature under pressure.[3] The reaction is typically catalyzed by metal salts, with zinc, mercury, and palladium compounds being historically employed.[3]

The underlying mechanism involves the activation of the carboxylic acid and acetylene by the catalyst, facilitating the addition of the carboxylate group across the triple bond.

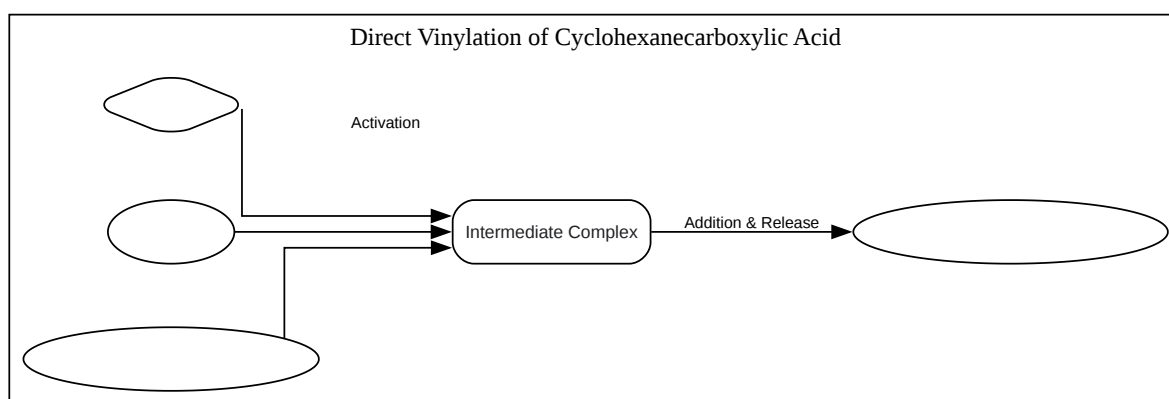

[Click to download full resolution via product page](#)

Caption: Generalized workflow for the direct vinylation synthesis of **Vinyl Cyclohexanecarboxylate**.

A typical laboratory-scale synthesis would involve bubbling acetylene through a solution of cyclohexanecarboxylic acid in an inert solvent containing the catalyst at elevated temperatures.

Transvinylation with Vinyl Acetate

A more contemporary and arguably safer approach is transvinylation, where the vinyl group is exchanged from a readily available vinyl ester, most commonly vinyl acetate, to cyclohexanecarboxylic acid.[3] This method obviates the need for handling acetylene gas. The

reaction is catalyzed by transition metal complexes, with palladium and ruthenium catalysts showing high efficacy.[3]

The equilibrium nature of this reaction often necessitates the removal of the by-product, acetic acid, to drive the reaction towards the formation of the desired **vinyl cyclohexanecarboxylate**.

Experimental Protocol: Transvinylation Synthesis of **Vinyl Cyclohexanecarboxylate**

- **Reactor Setup:** A three-necked round-bottom flask equipped with a magnetic stirrer, a reflux condenser, and a nitrogen inlet is charged with cyclohexanecarboxylic acid (1 equivalent), vinyl acetate (excess, e.g., 5-10 equivalents, also serving as the solvent), and a suitable catalyst (e.g., palladium(II) acetate with a phosphine ligand, 0.1-1 mol%).
- **Inert Atmosphere:** The system is purged with nitrogen to exclude oxygen and moisture.
- **Reaction:** The reaction mixture is heated to reflux (the boiling point of vinyl acetate is approximately 72 °C) and stirred for a specified period (e.g., 12-24 hours), monitoring the progress by techniques like TLC or GC.
- **Work-up:** After cooling to room temperature, the excess vinyl acetate is removed under reduced pressure. The residue is then dissolved in an organic solvent like diethyl ether and washed with a saturated sodium bicarbonate solution to remove unreacted carboxylic acid and the acetic acid by-product. The organic layer is subsequently washed with brine, dried over anhydrous magnesium sulfate, and filtered.
- **Purification:** The crude product is purified by vacuum distillation to yield pure **vinyl cyclohexanecarboxylate**.

Reactivity and Polymerization Behavior

The chemical reactivity of **vinyl cyclohexanecarboxylate** is dominated by the vinyl group, which readily undergoes radical polymerization. The ester functionality, while generally stable, can be susceptible to hydrolysis under acidic or basic conditions, a factor to consider in the applications of its polymers.

Free-Radical Polymerization

Vinyl cyclohexanecarboxylate is an excellent monomer for free-radical polymerization, a process initiated by the decomposition of a radical initiator to produce free radicals.[4] These radicals then attack the carbon-carbon double bond of the monomer, initiating a chain reaction that leads to the formation of a high molecular weight polymer, poly(**vinyl cyclohexanecarboxylate**).[4][5]

Commonly used initiators include benzoyl peroxide and 2,2'-azobis(isobutyronitrile) (AIBN).[4] The polymerization can be carried out in bulk, solution, suspension, or emulsion, with the choice of method influencing the polymer's properties and applications.

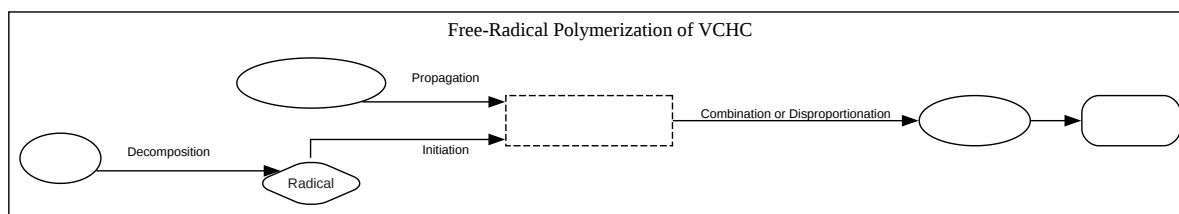

[Click to download full resolution via product page](#)

Caption: Schematic of the free-radical polymerization process for **Vinyl Cyclohexanecarboxylate**.

The presence of the bulky cyclohexyl group can influence the polymerization kinetics and the stereoregularity of the resulting polymer chain.

Properties of Poly(vinyl cyclohexanecarboxylate)

Polymers derived from **vinyl cyclohexanecarboxylate** exhibit a unique combination of properties stemming from the cycloaliphatic side chain:

- **High Chemical Resistance:** The hydrophobic and sterically hindered cyclohexyl group provides excellent resistance to hydrolysis and chemical attack.[6]

- **Good Adhesion:** The ester functionality can contribute to good adhesion to various substrates.
- **Low-Temperature Flexibility:** The non-polar, bulky side group can disrupt chain packing, leading to enhanced flexibility at lower temperatures.[2]
- **Thermal Stability:** The presence of the cyclohexane ring can enhance the thermal stability of the polymer.[6]

These properties make poly(**vinyl cyclohexanecarboxylate**) and its copolymers valuable in applications such as specialty coatings, adhesives, and composite materials.[2]

Spectroscopic Characterization

The structural elucidation and purity assessment of **vinyl cyclohexanecarboxylate** are routinely performed using a combination of spectroscopic techniques.

Nuclear Magnetic Resonance (NMR) Spectroscopy

- **¹H NMR:** The proton NMR spectrum provides a detailed map of the hydrogen atoms in the molecule. Key expected signals include those for the vinyl protons (typically in the range of 4.5-7.5 ppm) and the protons of the cyclohexyl ring (typically in the more upfield region of 1.0-2.5 ppm). The splitting patterns of the vinyl protons can provide information about their coupling to each other.
- **¹³C NMR:** The carbon-13 NMR spectrum reveals the different carbon environments. Distinct signals are expected for the vinyl carbons (sp² hybridized, typically downfield), the carbonyl carbon of the ester group (also downfield), and the sp³ hybridized carbons of the cyclohexyl ring (upfield).

Infrared (IR) Spectroscopy

The IR spectrum is invaluable for identifying the key functional groups. Characteristic absorption bands for **vinyl cyclohexanecarboxylate** include:

- **C=O Stretch (Ester):** A strong absorption band is expected around 1720-1740 cm⁻¹, characteristic of the carbonyl group in an ester.[7]

- C=C Stretch (Alkene): A medium intensity band around 1640-1680 cm^{-1} is indicative of the carbon-carbon double bond of the vinyl group.[8]
- =C-H Stretch (Alkene): A band above 3000 cm^{-1} (typically 3010-3100 cm^{-1}) corresponds to the stretching of the C-H bonds on the vinyl group.[8]
- C-H Stretch (Alkane): Strong absorptions below 3000 cm^{-1} (typically 2850-2960 cm^{-1}) are due to the C-H bonds of the cyclohexyl ring.[8]
- C-O Stretch (Ester): Bands in the region of 1000-1300 cm^{-1} are associated with the C-O single bond stretches of the ester group.

Mass Spectrometry (MS)

Mass spectrometry provides information about the molecular weight and fragmentation pattern of the molecule. For **vinyl cyclohexanecarboxylate** (MW = 154.21), the molecular ion peak (M^+) would be observed at m/z 154. Common fragmentation patterns would likely involve the loss of the vinyl group or cleavage of the ester bond, leading to characteristic fragment ions. PubChem lists a top peak at m/z 83 and a second highest at m/z 55 in the GC-MS data.[1]

Safety and Handling

As with any chemical substance, proper handling and safety precautions are paramount when working with **vinyl cyclohexanecarboxylate**. The information provided here is a summary and should be supplemented with a thorough review of the full Safety Data Sheet (SDS).

- General Handling: Use in a well-ventilated area.[9] Avoid contact with skin, eyes, and clothing.[10] Wear appropriate personal protective equipment (PPE), including safety glasses, gloves, and a lab coat.[9]
- Fire Hazards: The flash point is 85.1 °C, indicating it is a combustible liquid. Keep away from heat, sparks, and open flames.[11]
- Health Hazards: Specific toxicity data is limited in the provided search results. Inhalation of high vapor concentrations may cause symptoms like headache and dizziness.[10]
- Storage: Store in a cool, dry, well-ventilated place in a tightly sealed container.[11]

Concluding Remarks: A Monomer of Significant Promise

Vinyl cyclohexanecarboxylate stands out as a monomer with a compelling set of properties that translate into high-performance polymers. Its robust cycloaliphatic structure imparts excellent chemical and thermal stability, while the reactive vinyl group allows for facile polymerization and copolymerization. This guide has provided a comprehensive overview of its chemical identity, synthesis, reactivity, and characterization. As the demand for advanced materials continues to grow, the unique attributes of **vinyl cyclohexanecarboxylate** will undoubtedly secure its place as a valuable tool in the arsenal of polymer chemists and material scientists, driving innovation in coatings, adhesives, composites, and beyond.

References

- PubChem. **Vinyl cyclohexanecarboxylate**. National Center for Biotechnology Information. [\[Link\]](#)
- LookChem. Cas 4840-76-0, **vinyl cyclohexanecarboxylate**. [\[Link\]](#)
- International Journal of Advanced Research. DECOMPOSITION OF VINYL ESTERS OF CYCLOALIPHATIC EPOXY RESINS: A KINETIC STUDY. [\[Link\]](#)
- Safety Data Sheet. 4-Vinylcyclohexene. [\[Link\]](#)
- Royal Society of Chemistry. Electronic Supplementary Information for: Cationic Ring-Opening Polymerization of Vinyl-Cyclohexene Oxide. [\[Link\]](#)
- PubMed. Controlling Polymer Composition in Organocatalyzed Photoredox Radical Ring-Opening Polymerization of Vinylcyclopropanes. [\[Link\]](#)
- SKKU Scholar. Synthesis of 1,4-Cyclohexanedimethanol Bis(aliphatic carboxylate) Plasticizers and Its Application to Poly(vinyl chloride) Fabrication. [\[Link\]](#)
- Royal Society of Chemistry. Copies of 1H, 13C, 19F NMR spectra. [\[Link\]](#)
- Google Patents.

- Chemical Review and Letters. Vinyl esters of carboxylic acids: Synthesis, properties, applications, and technological processes. [\[Link\]](#)
- YouTube. differences & similarities of ^1H & ^{13}C NMR spectroscopy. [\[Link\]](#)
- MDPI. Virtual Free-Radical Polymerization of Vinyl Monomers in View of Digital Twins. [\[Link\]](#)
- Polymer Science Learning Center. Free Radical Vinyl Polymerization. [\[Link\]](#)
- Beilstein Journal of Organic Chemistry. Ambient gold-catalyzed O-vinylation of cyclic 1,3-diketone: A vinyl ether synthesis. [\[Link\]](#)
- ChemRxiv. Synthesis of Vinyl Sulfones from Substituted Alkenes via Molybdooxaziridine Catalysis. [\[Link\]](#)
- Polymer Innovation Blog. Thermoset Polymers: Vinyl Esters. [\[Link\]](#)
- ResearchGate. Optimization of reaction conditions in the synthesis of vinyl thioesters a. [\[Link\]](#)
- PubChem. Vinylcyclohexane. [\[Link\]](#)
- Google Patents. CN102408646A - Plasticised polyvinyl chloride.
- SpringerLink. Characterization of the chemical structure of vinyl ester resin in a climate chamber under different conditions of degradation. [\[Link\]](#)
- Royal Society of Chemistry. (Controlled) Free Radical (Co)polymerization of Multivinyl Monomers: Strategies, Topological Structures and Biomedical Applications. [\[Link\]](#)
- Polymer Source. Poly(vinyl cyclohexane), functionalized. [\[Link\]](#)
- ResearchGate. Controlled free-radical polymerization of vinyl chloride. [\[Link\]](#)
- Chemistry LibreTexts. 11.5: Infrared Spectra of Some Common Functional Groups. [\[Link\]](#)
- NC State University Libraries. 12.6 Infrared Spectra of Some Common Functional Groups – Organic Chemistry. [\[Link\]](#)

- PCC Group. Polyvinyl chloride: uses and properties. [[Link](#)]

Need Custom Synthesis?

BenchChem offers custom synthesis for rare earth carbides and specific isotopic labeling.

Email: info@benchchem.com or [Request Quote Online](#).

Sources

- 1. Vinyl cyclohexanecarboxylate | C₉H₁₄O₂ | CID 20985 - PubChem [pubchem.ncbi.nlm.nih.gov]
- 2. Cas 4840-76-0, vinyl cyclohexanecarboxylate | [lookchem](https://lookchem.com) [lookchem.com]
- 3. chemrevlett.com [chemrevlett.com]
- 4. pslc.ws [pslc.ws]
- 5. rua.ua.es [rua.ua.es]
- 6. journalijar.com [journalijar.com]
- 7. chem.libretexts.org [chem.libretexts.org]
- 8. 12.6 Infrared Spectra of Some Common Functional Groups – Organic Chemistry: A Tenth Edition – OpenStax adaptation 1 [ncstate.pressbooks.pub]
- 9. store.apolloscientific.co.uk [store.apolloscientific.co.uk]
- 10. fishersci.com [fishersci.com]
- 11. sigmaaldrich.cn [sigmaaldrich.cn]
- To cite this document: BenchChem. [An In-depth Technical Guide to Vinyl Cyclohexanecarboxylate (CAS 4840-76-0)]. BenchChem, [2026]. [Online PDF]. Available at: [<https://www.benchchem.com/product/b3052926/docs#an-in-depth-technical-guide-to-vinyl-cyclohexanecarboxylate-cas-4840-76-0>]

Disclaimer & Data Validity:

The information provided in this document is for Research Use Only (RUO) and is strictly not intended for diagnostic or therapeutic procedures. While BenchChem strives to provide

accurate protocols, we make no warranties, express or implied, regarding the fitness of this product for every specific experimental setup.

Technical Support: The protocols provided are for reference purposes. Unsure if this reagent suits your experiment?

Need Industrial/Bulk Grade? [Request Custom Synthesis Quote](#)

BenchChem

Our mission is to be the trusted global source of essential and advanced chemicals, empowering scientists and researchers to drive progress in science and industry.

Contact

Address: 3281 E Guasti Rd
Ontario, CA 91761, United States
Phone: (601) 213-4426
Email: info@benchchem.com

[Contact our Ph.D. Support Team for a compatibility check](#)