

# Precision Analytics in Small Molecule Characterization: The C<sub>14</sub>H<sub>9</sub>NO<sub>4</sub> Case Study

**Author:** BenchChem Technical Support Team. **Date:** April 2026

## Compound of Interest

Compound Name:	9h-Carbazole-3,6-dicarboxylic acid
CAS No.:	3215-41-6
Cat. No.:	B3051222

[Get Quote](#)

## Executive Summary

In the high-stakes environment of drug discovery and metabolomics, the chemical formula C<sub>14</sub>H<sub>9</sub>NO<sub>4</sub> represents a critical class of highly conjugated, oxidized nitrogenous compounds—often manifesting as synthetic intermediates (e.g., nitro-diketones) or secondary metabolites (e.g., functionalized fluorenones).[1]

This technical guide moves beyond basic stoichiometry to address the analytical challenges associated with this formula. We will establish the definitive monoisotopic mass standards, analyze the degree of unsaturation to predict structural motifs, and define a self-validating High-Resolution Mass Spectrometry (HRMS) workflow to distinguish C<sub>14</sub>H<sub>9</sub>NO<sub>4</sub> from isobaric interferences.[1]

## Part 1: Theoretical Foundations & Constants[1]

### The Exact Mass vs. Molecular Weight Distinction

For a researcher operating a Triple Quadrupole or Orbitrap MS, "Molecular Weight" is an inadequate metric.[1] You must operate with the Monoisotopic Mass to correctly set quadrupole

isolation windows and identify parent ions.

- Monoisotopic Mass (Exact Mass): Calculated using the mass of the primary isotope of each element (
   
 ).<sup>[1]</sup><sup>[2]</sup> This is the value observed in the first spectral peak (M).
- Average Molecular Weight: The weighted average of all natural isotopes. This value is relevant only for bulk stoichiometric calculations (e.g., weighing powder for a stock solution), not for spectral identification.

## Definitive Calculation Table (2024 IUPAC Standards)

The following table uses the most current IUPAC atomic weights and isotopic masses.

Element	Isotope	Exact Mass (Da)	Count	Total Mass Contribution (Da)
Carbon		12.00000	14	168.00000
Hydrogen		1.00783	9	9.07047
Nitrogen		14.00307	1	14.00307
Oxygen		15.99491	4	63.97964
TOTAL	(M)	255.05318		

Critical Analytical Values:

- Monoisotopic Mass (
   
 ):255.0532 Da<sup>[1]</sup>
- Protonated Ion (
   
 ):
   
<sup>[1]</sup>

- Deprotonated Ion ( ):  
• Average Molecular Weight: 255.22 g/mol (For gravimetric prep)

## Structural Implications (Degree of Unsaturation)

To understand what C<sub>14</sub>H<sub>9</sub>NO<sub>4</sub> is, we calculate the Degree of Unsaturation (DoU):

[1]

Interpretation: A DoU of 11 indicates a highly condensed structure. This typically corresponds to:

- Tricyclic Aromatic Systems: e.g., Fluorenone or Anthracene derivatives (3 rings = 10-12 DoU depending on double bonds).[1]
- Nitro/Carbonyl Groups: The 4 oxygens are likely distributed as nitro ( , 1 DoU) and ketone/quinone carbonyls ( , 1 DoU).[1]

## Part 2: Analytical Strategy & Differentiation

Distinguishing C<sub>14</sub>H<sub>9</sub>NO<sub>4</sub> from isobars (molecules with similar mass but different formulas) requires high-resolution capability.

### The Isobaric Challenge

Consider a potential contaminant with formula C<sub>13</sub>H<sub>13</sub>N<sub>4</sub>O.

- Mass:  
.[1]
- Difference:

- Requirement: To resolve these peaks at

, you need a resolution of at least 10,000 FWHM.[1] A standard Orbitrap or Q-TOF easily achieves this, but a low-res single quad will merge them.[1]

## Isotopic Pattern Verification (Self-Validating Logic)

A self-validating protocol uses the Carbon-13 isotope peak (

) to confirm the carbon count.

- Theory:

abundance is

[1]

- Calculation for C14:

[1]

- Validation Rule: If your mass spectrum shows a parent peak at 255.05 and an M+1 peak at 256.05 with an intensity of ~15% relative to the parent, you have confirmed the presence of ~14 carbons.[1] If the M+1 is only 5%, your formula is wrong (likely fewer carbons, more heteroatoms).[1]

## Visualizing the Analytical Workflow

The following diagram outlines the decision logic for confirming C<sub>14</sub>H<sub>9</sub>NO<sub>4</sub> identity.

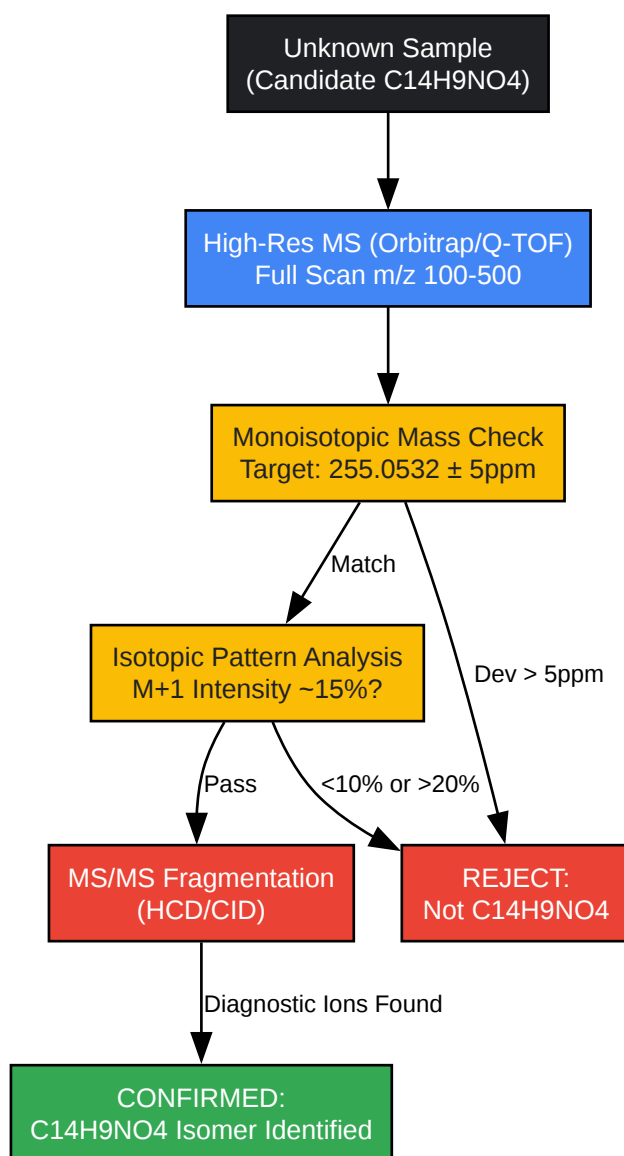

[Click to download full resolution via product page](#)

Figure 1: Step-by-step decision tree for validating C<sub>14</sub>H<sub>9</sub>NO<sub>4</sub> using High-Resolution Mass Spectrometry.

## Part 3: Isomer Differentiation (Advanced Structural Elucidation)

The formula C<sub>14</sub>H<sub>9</sub>NO<sub>4</sub> is not unique. Two common isomers in drug development libraries illustrate the need for MS/MS fragmentation.

## Candidate Isomers

- Isomer A: 2-(2-Nitrophenyl)-1-phenylethanedione
  - Structure: Two phenyl rings connected by a dicarbonyl bridge, with a nitro group.[\[1\]](#)
  - Fragmentation: Cleavage of the dicarbonyl bridge yields benzoyl ions (105).
- Isomer B: 1-Methoxy-2-nitro-fluoren-9-one
  - Structure: Tricyclic fused ring system (fluorenone) with methoxy and nitro substituents.
  - Fragmentation: Loss of methyl radical ( ) or ( ) or ( ). Highly stable core.[\[1\]](#)

## MS/MS Fragmentation Protocol

To distinguish these, apply collision energy (NCE 30-40%) and look for diagnostic neutral losses.[\[1\]](#)

Feature	Isomer A (Diketone)	Isomer B (Fluorenone)
Primary Loss	-cleavage (C-C bond break)	Neutral loss of or
Diagnostic Ion	105 (Benzoyl cation)	225 ( )
Stability	Low (fragments easily)	High (fused rings resist breaking)

## Fragmentation Pathway Diagram

The following diagram illustrates how MS/MS differentiates the fused ring system from the open dicarbonyl system.

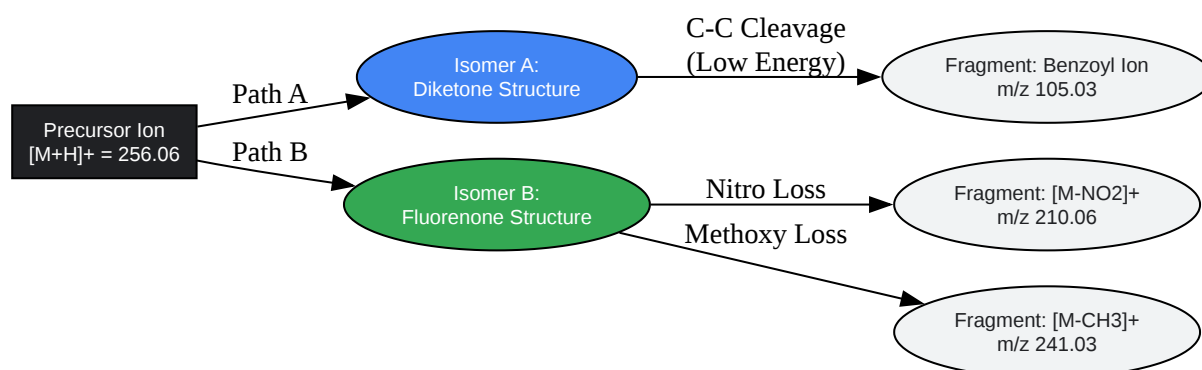

[Click to download full resolution via product page](#)

Figure 2: Divergent fragmentation pathways for common C<sub>14</sub>H<sub>9</sub>NO<sub>4</sub> isomers.

## Part 4: Standard Operating Procedure (SOP)

### Sample Preparation

- Solvent: C<sub>14</sub>H<sub>9</sub>NO<sub>4</sub> compounds are typically lipophilic. Dissolve in 100% DMSO to 10 mM stock.
- Working Solution: Dilute to 1 μM in 50:50 Acetonitrile:Water + 0.1% Formic Acid.
  - Note: Avoid 100% aqueous buffers; these compounds may precipitate.[1]

### LC-MS Conditions

- Column: C18 Reverse Phase (e.g., Waters BEH C18, 2.1 x 50mm).[1]
- Mobile Phase A: Water + 0.1% Formic Acid.[1]
- Mobile Phase B: Acetonitrile + 0.1% Formic Acid.[1]

- Gradient: 5% B to 95% B over 5 minutes.
  - Rationale: High DoU (11) implies significant hydrophobicity; expect retention times > 3.5 min.

## Data Analysis Checklist

Extract Ion Chromatogram (EIC) for

256.0605 (Tolerance  $\pm$  5 ppm).

Verify Isotopic Pattern: M+1 peak should be  $\sim$ 15% of M.[1]

Check MS/MS:

- If

105 is dominant

Suspect Diketone.

- If

241/210 is dominant

Suspect Fluorenone derivative.

## References

- IUPAC Commission on Isotopic Abundances and Atomic Weights. (2024).[3][4][5] Standard Atomic Weights of the Elements. International Union of Pure and Applied Chemistry.[4][5][6] [\[Link\]](#)[5]
- National Institute of Standards and Technology (NIST). (2023). Atomic Weights and Isotopic Compositions for All Elements. NIST Physical Measurement Laboratory.[1] [\[Link\]](#)
- Kind, T., & Fiehn, O. (2007).[1] Seven Golden Rules for heuristic filtering of molecular formulas obtained by accurate mass spectrometry. BMC Bioinformatics.[1] [\[Link\]](#)

### Need Custom Synthesis?

BenchChem offers custom synthesis for rare earth carbides and specific isotopic labeling.

Email: [info@benchchem.com](mailto:info@benchchem.com) or [Request Quote Online](#).

## Sources

- 1. Masses [[www2.chemistry.msu.edu](http://www2.chemistry.msu.edu)]
- 2. Exact Mass Calculator | Fast & Free | BioChemCalc [[biochemcalc.com](http://biochemcalc.com)]
- 3. Standard Atomic Weights | Commission on Isotopic Abundances and Atomic Weights [[ciaaw.org](http://ciaaw.org)]
- 4. [pubs.acs.org](http://pubs.acs.org) [[pubs.acs.org](http://pubs.acs.org)]
- 5. [iupac.org](http://iupac.org) [[iupac.org](http://iupac.org)]
- 6. [iupac.org](http://iupac.org) [[iupac.org](http://iupac.org)]
- To cite this document: BenchChem. [Precision Analytics in Small Molecule Characterization: The C14H9NO4 Case Study]. BenchChem, [2026]. [Online PDF]. Available at: [<https://www.benchchem.com/product/b3051222/docs#precision-analytics-in-small-molecule-characterization-the-c14h9no4-case-study>]

---

### Disclaimer & Data Validity:

The information provided in this document is for Research Use Only (RUO) and is strictly not intended for diagnostic or therapeutic procedures. While BenchChem strives to provide accurate protocols, we make no warranties, express or implied, regarding the fitness of this product for every specific experimental setup.

**Technical Support:** The protocols provided are for reference purposes. Unsure if this reagent suits your experiment?

**Need Industrial/Bulk Grade?** [Request Custom Synthesis Quote](#)

# BenchChem

Our mission is to be the trusted global source of essential and advanced chemicals, empowering scientists and researchers to drive progress in science and industry.

## Contact

Address: 3281 E Guasti Rd

Ontario, CA 91761, United States

Phone: (601) 213-4426

Email: [info@benchchem.com](mailto:info@benchchem.com)

[Contact our Ph.D. Support Team for a compatibility check](#)