

# Introduction: The Critical Role of Cesium-Selective Potentiometry

**Author:** BenchChem Technical Support Team. **Date:** May 2026

## Compound of Interest

Compound Name: *Cesium tetrphenylborate*

CAS No.: 3087-82-9

Cat. No.: B3051080

[Get Quote](#)

The precise and selective measurement of cesium ions ( $\text{Cs}^+$ ) is paramount in fields ranging from environmental monitoring, particularly concerning radioactive  $^{137}\text{Cs}$  isotopes, to industrial process control and fundamental chemical research.[1] Among the various analytical techniques available, potentiometry using ion-selective electrodes (ISEs) offers a compelling combination of simplicity, cost-effectiveness, and real-time measurement capability.

At the heart of many high-performance cesium ISEs lies the ion-exchanging material, **Cesium Tetrphenylborate** ( $\text{CsB}(\text{C}_6\text{H}_5)_4$ ). The exceptionally low aqueous solubility of this salt is a key attribute that drives the selective recognition of  $\text{Cs}^+$  ions within the electrode's sensing membrane.[2] This application note provides a comprehensive guide for researchers, scientists, and drug development professionals on the principles, fabrication, and operation of cesium ISEs based on **Cesium Tetrphenylborate**. We will delve into the causality behind experimental choices, provide detailed, field-proven protocols, and outline the performance characteristics of these critical analytical tools.

## Principle of Operation: A Mechanistic Overview

A cesium ion-selective electrode operates by measuring the potential difference that develops across a selective membrane separating the sample solution from an internal reference solution. This potential is proportional to the activity of cesium ions in the sample. The core components enabling this measurement are integrated into a PVC-based liquid membrane.

- The Ion Exchanger (**Cesium Tetrphenylborate**): Unlike neutral carrier ionophores that sequester ions within a cavity, **Cesium Tetrphenylborate** acts as a charged ion exchanger. The tetrphenylborate (TPB<sup>-</sup>) anion is a lipophilic (oil-loving) species that is mobile within the organic polymer membrane but immiscible with the aqueous sample. When the membrane is exposed to a sample containing Cs<sup>+</sup>, an ion-exchange equilibrium is established at the membrane-sample interface:



The exceptionally low solubility product (K<sub>sp</sub>) of CsTPB, approximately  $7.84 \times 10^{-10}$  at 25°C, strongly favors the partitioning of Cs<sup>+</sup> ions from the aqueous phase into the membrane phase.[2] This selective uptake of positive charge at the interface generates a phase-boundary potential.

- The Polymeric Matrix (PVC): High molecular weight poly(vinyl chloride) provides the physical support and structural integrity for the membrane, entrapping the active components.
- The Plasticizer: A plasticizer is a critical, non-volatile organic liquid that constitutes a significant portion of the membrane (typically ~60-70% by weight).[3] Its primary functions are:
  - To lower the glass transition temperature of the PVC, rendering the membrane non-rigid and ensuring the mobility of the ion exchanger.[4]
  - To act as an organic solvent that dissolves the ion exchanger (CsTPB) and any additives. [5][6]
  - To control the dielectric constant of the membrane, which influences the ion-exchange equilibrium and, consequently, the electrode's selectivity and sensitivity.[3] Common plasticizers include 2-nitrophenyl octyl ether (o-NPOE) and bis(2-ethylhexyl) sebacate (DOS). The choice of plasticizer can significantly impact electrode lifetime and performance.[7]

The potential difference across the membrane is measured relative to an external reference electrode (e.g., Ag/AgCl), and the relationship between the measured potential (E) and the cesium ion activity ( $a_{\text{Cs}^+}$ ) is described by the Nernst equation:

$$E = E_0 + (2.303 RT / zF) * \log(a_{\text{Cs}^+})$$

Where  $E_0$  is a constant potential term, R is the gas constant, T is the absolute temperature, F is the Faraday constant, and z is the charge of the ion (+1 for  $\text{Cs}^+$ ). At 25°C, the term  $(2.303 RT / zF)$  is approximately 59.16 mV for a monovalent cation.

## Protocol 1: Fabrication of a Cesium Ion-Selective Electrode

This protocol details the preparation of the PVC membrane and its assembly into a functional electrode. All reagents should be of analytical grade.

### Required Reagents and Materials

- **Cesium Tetrphenylborate** ( $\text{CsTPB}$ )
- Poly(vinyl chloride) (PVC), high molecular weight
- Plasticizer: 2-Nitrophenyl octyl ether (o-NPOE)
- Solvent: Tetrahydrofuran (THF), inhibitor-free
- Cesium chloride ( $\text{CsCl}$ ), for internal filling solution
- Glass Petri dish (5 cm diameter)
- Electrode body (e.g., Phillips-type)
- Internal reference electrode ( $\text{Ag}/\text{AgCl}$  wire)

### Preparation of the Membrane Cocktail

The following composition is a robust starting point for a highly selective cesium membrane.

Component	Weight %	Typical Mass (for 200 mg total)	Function
Cesium Tetrphenylborate (CsTPB)	2.0%	4.0 mg	Ion Exchanger
2-Nitrophenyl octyl ether (o-NPOE)	65.0%	130.0 mg	Plasticizer/Membrane Solvent
Poly(vinyl chloride) (PVC)	33.0%	66.0 mg	Polymer Matrix

Procedure:

- Accurately weigh the PVC, o-NPOE, and **Cesium Tetrphenylborate** into a small glass vial.
- Add approximately 3-5 mL of THF to the vial.
- Seal the vial and agitate gently (e.g., on a magnetic stirrer or rotator) until all components are fully dissolved, forming a clear, slightly viscous solution. This is the "membrane cocktail." [8]

## Membrane Casting and Electrode Assembly

This workflow outlines the process from the prepared cocktail to a functional electrode.



[Click to download full resolution via product page](#)

Caption: Workflow for the fabrication of a Cs-ISE.

Detailed Steps:

- Pour the prepared membrane cocktail into a clean, level glass Petri dish.[8]
- Cover the dish loosely (e.g., with a filter paper) to allow for slow solvent evaporation in a dust-free environment at room temperature. This process typically takes 24 hours.[8]
- Once the THF has completely evaporated, a transparent, flexible membrane approximately 0.5 mm thick will remain.
- Carefully peel the membrane from the glass surface.
- Using a cork borer, cut a small disc (5-7 mm diameter) from a visually homogeneous section of the membrane.
- Securely mount the membrane disc onto the end of the ISE electrode body using a PVC/THF slurry or an appropriate adhesive. Ensure a leak-proof seal.
- Fill the electrode body with the internal filling solution (0.1 M CsCl).
- Insert the internal Ag/AgCl reference electrode, ensuring it is immersed in the filling solution and that no air bubbles are trapped.
- Conditioning: Before its first use, immerse the tip of the newly fabricated Cs-ISE in a 0.01 M CsCl solution for at least 12-24 hours.[9] This step is crucial for establishing stable equilibrium at the membrane interfaces and ensuring a reproducible potential.

## Protocol 2: Potentiometric Measurement & Calibration

Accurate measurements are contingent on proper calibration. This protocol describes the setup and procedure for creating a calibration curve and measuring an unknown sample.

### Measurement Setup

The required equipment includes the fabricated Cs-ISE, a double-junction Ag/AgCl external reference electrode, a high-impedance pH/mV meter, a magnetic stirrer, and standard laboratory glassware.

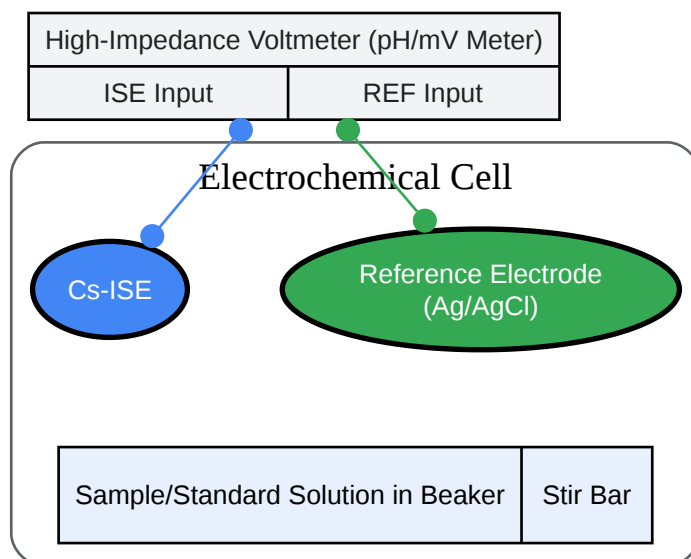

[Click to download full resolution via product page](#)

Caption: Diagram of the potentiometric measurement setup.

## Calibration Procedure

- **Prepare Standards:** Prepare a series of CsCl standard solutions by serial dilution of a 1.0 M stock solution. A typical range would be  $10^{-1}$  M,  $10^{-2}$  M,  $10^{-3}$  M,  $10^{-4}$  M,  $10^{-5}$  M, and  $10^{-6}$  M.[10]
- **Ionic Strength Adjustment:** For samples with complex or variable matrices, it is highly recommended to add an Ionic Strength Adjustor (ISA) to both samples and standards in equal measure (e.g., 2 mL of ISA per 100 mL solution).[11] A suitable ISA for this purpose could be a solution of 1 M NaCl, which helps to swamp out minor variations in ionic strength and minimize junction potential effects.[9]
- **Measure Potentials:**
  - Begin with the most dilute standard ( $10^{-6}$  M) to minimize carryover.[12]
  - Place 50-100 mL of the standard in a beaker with a magnetic stir bar.
  - Rinse the electrodes with deionized water and gently blot dry with a lint-free tissue.[13]

- Immerse the Cs-ISE and reference electrode in the solution.
- Stir at a constant, moderate rate.
- Record the potential (in mV) once the reading has stabilized (typically within 30-60 seconds).
- Repeat this process for each standard, moving from lowest to highest concentration.[\[11\]](#)
- Construct Calibration Curve: Plot the stable potential reading (E, in mV) on the y-axis against the logarithm of the cesium concentration ( $\log[\text{Cs}^+]$ ) on the x-axis. The resulting plot should be linear over a wide concentration range.
- Evaluate Performance: Calculate the slope of the linear portion of the graph. A slope between 52-62 mV per decade of concentration at  $\sim 25^\circ\text{C}$  indicates a proper, near-Nernstian response for a monovalent cation.[\[11\]](#)

## Sample Measurement

- Pre-treat the sample as necessary (e.g., pH adjustment, addition of ISA).
- Rinse and immerse the calibrated electrodes into the sample solution.
- Record the stabilized potential.
- Determine the logarithm of the cesium concentration from the calibration curve using the measured potential. Calculate the concentration of the unknown sample.

## Performance Characteristics and Interferences

The performance of a CsTPB-based electrode is defined by several key parameters.

## Typical Performance Data

Parameter	Typical Value	Significance
Linear Range	$1.0 \times 10^{-5} \text{ M}$ to $1.0 \times 10^{-1} \text{ M}$	The concentration range over which the electrode exhibits a linear, Nernstian response.[14]
Nernstian Slope	$55 \pm 4 \text{ mV/decade}$	Indicates ideal electrode response to changes in ion activity.[14]
Limit of Detection	$\sim 5.0 \times 10^{-6} \text{ M}$	The lowest concentration at which the signal can be reliably distinguished from the baseline.[14]
Response Time	< 30 seconds	The time required to reach a stable potential reading after immersion in a new solution. [14]
Operational pH Range	3.0 – 9.5	The pH range where the electrode potential is independent of $\text{H}^+$ ion concentration.[14]
Lifetime	> 1 month	The duration for which the electrode maintains its performance characteristics with proper storage.[14]

## Selectivity and Interferences

Electrode selectivity is its ability to distinguish the primary ion ( $\text{Cs}^+$ ) from other interfering ions present in the sample. It is quantified by the selectivity coefficient,  $K_{\text{pot}}(\text{Cs}^+, \text{B})$ , where B is the interfering ion. A smaller  $K_{\text{pot}}$  value signifies better selectivity.

Typical Selectivity Coefficients ( $\log K_{\text{pot}}(\text{Cs}^+, \text{B})$ )

Interfering Ion (B)	log K_pot_	Potential Impact
Rubidium (Rb <sup>+</sup> )	-1.5	High interference potential due to similar ionic radius and chemistry.
Potassium (K <sup>+</sup> )	-2.5	Moderate interference; a common ion in many samples.
Ammonium (NH <sub>4</sub> <sup>+</sup> )	-2.7	Moderate interference.
Sodium (Na <sup>+</sup> )	-3.7	Low interference.
Lithium (Li <sup>+</sup> )	-4.4	Very low interference.
Magnesium (Mg <sup>2+</sup> )	-3.9	Very low interference.
Calcium (Ca <sup>2+</sup> )	-4.0	Very low interference.

(Data synthesized from representative values for similar cation-selective electrodes)

The primary interferents for the cesium electrode are other alkali metal cations with similar ionic radii, most notably Rb<sup>+</sup> and K<sup>+</sup>.<sup>[15]</sup> High concentrations of these ions can lead to erroneously high readings for cesium. It is crucial for researchers to be aware of the potential ionic composition of their samples when interpreting results.

## References

- Polymeric plasticizer extends the lifetime of PVC-membrane ion-selective electrodes. Analyst (RSC Publishing).
- Plasticizer-level study of poly(vinyl chloride) ion-selective membranes. PubMed.
- Influence of different plasticizers on the response of chemical sensors based on polymeric membranes for nitrate ion determination. scielo.cl.
- Plasticizer Effects in the PVC Membrane of the Dibasic Phosphate Selective Electrode. NIH.
- Plasticizer Effects in the PVC Membrane of the Dibasic Phosphate Selective Electrode. ResearchGate.
- Polymeric membrane coated graphite cesium selective electrode based on 4',4''(5') di-tert-butyl di-benzo-18-crown-6. ResearchGate.
- Determination of cesium ions in environmental water samples with a magnetic multi-walled carbon nanotube imprinted potentiometric sensor. RSC Publishing.

- Construction and Performance Characterization of Ion Selective Electrodes for Potentiometric Determination of Citapolarm Hydrobromide in Biological Fluids. Oriental Journal of Chemistry.
- Ion Selective Electrodes (ISEs) and interferences--a review. PubMed.
- Co-Ion Interference for Ion-Selective Electrodes Based on Charged and Neutral Ionophores: A Comparison. Experts@Minnesota.
- Using an Ion Selective Electrode. YouTube. Available at: [\[Link\]](#)
- Interference in Ion-Selective Electrodes Due to Proteins and Lipids. PubMed.
- Ion Selective Electrodes (ISEs) and interferences--a review. Semantic Scholar. Available at: [\[Link\]](#)
- Ion Selective Electrode Startup and Calibration Guide. Xylem. Available at: [\[Link\]](#)
- **Cesium tetrphenylborate**. PubChem. Available at: [\[Link\]](#)
- How to calibrate an Ion Selective Electrode Meter. Camlab. Available at: [\[Link\]](#)
- Calibrating Ion-Selective Electrodes: The Difference Between Activity and Concentration. Solinst. Available at: [\[Link\]](#)
- Ion-selective electrodes (ISE). radiometer-analytical.com. Available at: [\[Link\]](#)
- How to calibrate the ion selective? ResearchGate. Available at: [\[Link\]](#)
- Tetrphenylborate: In-Tank Precipitation and Small-Tank Precipitation Options. National Academies of Sciences, Engineering, and Medicine. Available at: [\[Link\]](#)

#### **Need Custom Synthesis?**

BenchChem offers custom synthesis for rare earth carbides and specific isotopic labeling.

Email: [info@benchchem.com](mailto:info@benchchem.com) or [Request Quote Online](#).

## Sources

- 1. Determination of cesium ions in environmental water samples with a magnetic multi-walled carbon nanotube imprinted potentiometric sensor - RSC Advances (RSC Publishing) DOI:10.1039/D0RA09659H [pubs.rsc.org]
- 2. nationalacademies.org [nationalacademies.org]
- 3. repositorio.uchile.cl [repositorio.uchile.cl]
- 4. Plasticizer-level study of poly(vinyl chloride) ion-selective membranes - PubMed [pubmed.ncbi.nlm.nih.gov]
- 5. Plasticizer Effects in the PVC Membrane of the Dibasic Phosphate Selective Electrode - PMC [pmc.ncbi.nlm.nih.gov]
- 6. researchgate.net [researchgate.net]
- 7. Polymeric plasticizer extends the lifetime of PVC-membrane ion-selective electrodes - Analyst (RSC Publishing) [pubs.rsc.org]
- 8. Construction and Performance Characterization of Ion Selective Electrodes for Potentiometric Determination of Citapolarom Hydrobromide in Biological Fluids – Oriental Journal of Chemistry [orientjchem.org]
- 9. Ion-selective electrodes: General tips - Part 1 | Metrohm [metrohm.com]
- 10. cma4ch.org [cma4ch.org]
- 11. xylem.com [xylem.com]
- 12. camlab.co.uk [camlab.co.uk]
- 13. youtube.com [youtube.com]
- 14. researchgate.net [researchgate.net]
- 15. Ion Selective Electrodes (ISEs) and interferences--a review - PubMed [pubmed.ncbi.nlm.nih.gov]
- To cite this document: BenchChem. [Introduction: The Critical Role of Cesium-Selective Potentiometry]. BenchChem, [2026]. [Online PDF]. Available at: [https://www.benchchem.com/product/b3051080/docs#introduction-the-critical-role-of-cesium-selective-potentiometry]

---

### Disclaimer & Data Validity:

The information provided in this document is for Research Use Only (RUO) and is strictly not intended for diagnostic or therapeutic procedures. While BenchChem strives to provide

accurate protocols, we make no warranties, express or implied, regarding the fitness of this product for every specific experimental setup.

**Technical Support:** The protocols provided are for reference purposes. Unsure if this reagent suits your experiment?

**Need Industrial/Bulk Grade?** [Request Custom Synthesis Quote](#)

## BenchChem

Our mission is to be the trusted global source of essential and advanced chemicals, empowering scientists and researchers to drive progress in science and industry.

### Contact

Address: 3281 E Guasti Rd

Ontario, CA 91761, United States

Phone: (601) 213-4426

Email: [info@benchchem.com](mailto:info@benchchem.com)

[Contact our Ph.D. Support Team for a compatibility check](#)