

Comparative Guide: Elucidating the Fragmentation Dynamics of 3-Cyclopenten-1-amine

Author: BenchChem Technical Support Team. **Date:** April 2026

Compound of Interest

Compound Name: Cyclopent-3-en-1-amine
CAS No.: 27721-59-1
Cat. No.: B3050663

[Get Quote](#)

Executive Summary & Scientific Context

3-Cyclopenten-1-amine (MW: 83.13 Da) represents a critical homoallylic amine scaffold in drug development, often serving as a precursor for conformationally restricted amino acid analogs and transition-state inhibitors.^[1]

In metabolic flux analysis and impurity profiling, this molecule presents a distinct challenge: distinguishing it from its saturated analog (Cyclopentanamine, MW: 85.15 Da) and aromatic isomers (e.g., N-methylpyrrole or 2-methyl-pyrrolidine).^[1]

This guide provides a mechanistic framework for interpreting the mass spectral fingerprint of 3-cyclopenten-1-amine.^[1] We contrast the Hard Ionization (EI) pathways—dominated by radical-driven ring openings—with Soft Ionization (ESI-MS/MS), where proton-driven eliminations prevail.^[1]

Structural Logic & Ionization Behavior^[2]

The presence of the C3-C4 double bond is the defining feature of 3-cyclopenten-1-amine. Unlike the saturated cyclopentanamine, this unsaturation opens specific "Retro-Diels-Alder-like" (RDA) fragmentation channels that serve as diagnostic markers.[1]

Table 1: Physicochemical & MS Profile Comparison[1]

Feature	3-Cyclopenten-1-amine (Target)	Cyclopentanamine (Control)	Differentiation Logic
Formula			Target is -2 Da (Unsaturation).[1]
MW (Monoisotopic)	83.0735 Da	85.0891 Da	High-Res MS resolves this easily.[1]
EI Molecular Ion ()	m/z 83 (Distinct)	m/z 85 (Distinct)	stability is lower in the amine due to -cleavage.
Dominant EI Pathway	-Cleavage + Retro-Cycloaddition	-Cleavage + H-Rearrangement	RDA is absent in the saturated control.
Base Peak (Predicted)	m/z 54 (Loss of) or m/z 68	m/z 56 () or m/z 30	Double bond stabilizes fragments.[1]

Deep Dive: Electron Ionization (EI) Fragmentation

In 70 eV Electron Ionization, the radical cation (, m/z 83) forms primarily by removing a lone-pair electron from the nitrogen. The subsequent fragmentation is a competition between -cleavage and allylic activation.[1]

Mechanism A: The "RDA-Like" Ethylene Extrusion (Diagnostic)

While true Retro-Diels-Alder requires a 6-membered ring, cyclopentene derivatives undergo a specific retro-cycloaddition driven by the stability of the conjugated products.

- Ionization: Removal of

from Nitrogen.[1]
- -Cleavage: The C1-C2 bond breaks, opening the ring.[1]
- Allylic Stabilization: The radical at C2 is stabilized by the adjacent double bond (if migration occurs) or the double bond participates in ejecting a neutral fragment.
- Result: Loss of Ethylene (

, 28 Da) or similar

fragments is facilitated by the unsaturation.[1]

Mechanism B: -Cleavage (Universal Amine Pathway)

Standard for all primary amines.[1] The bond adjacent to the C-N bond breaks.

- Pathway:

(83)

Ring Open

H-transfer

Formation of iminium ions.[1]
- Observation: In saturated cyclopentanamine, this leads to m/z 30 (

).[1] In 3-cyclopenten-1-amine, the rigidity of the double bond may suppress the formation of m/z 30 compared to the saturated analog.

Visualization: Fragmentation Pathways

The following diagram illustrates the competing pathways for the molecular ion m/z 83.

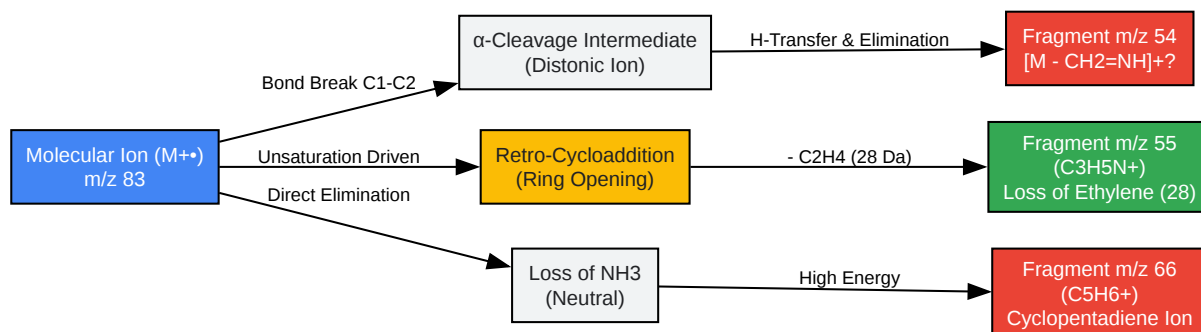

[Click to download full resolution via product page](#)

Caption: Figure 1.[1] Competing fragmentation pathways for 3-cyclopenten-1-amine (EI). The Retro-Cycloaddition path (green) is specific to the unsaturated analog.

ESI-MS/MS (Soft Ionization) Interpretation

In LC-MS (Electrospray), the molecule appears as the protonated species at m/z 84.

Collision-Induced Dissociation (CID)

Unlike EI, CID fragmentation is charge-driven (proton mobility).[1]

- Neutral Loss of Ammonia (

):

- Transition: m/z 84

m/z 67.

- Mechanism: Protonation on the amine makes it a good leaving group.[1] The resulting carbocation (m/z 67) is the cyclopentenyl cation.
- Stability: The m/z 67 cation is resonance-stabilized (allylic cation), making this transition highly abundant and lower energy than in the saturated analog (where the resulting cyclopentyl cation is less stable).

- Ring Opening:
 - High collision energy is required to break the C-C bonds of the m/z 67 ring.

Experimental Protocol: Distinguishing Isomers

To validate the identity of 3-cyclopenten-1-amine against its saturated or isomeric counterparts, use the following self-validating protocol.

Method: GC-MS (EI)[1][4]

- Column: Rtx-5Amine or equivalent (base-deactivated fused silica).[1]
- Inlet Temp: 250°C.
- Carrier Gas: Helium at 1.0 mL/min.[1]
- Oven Program: 40°C (hold 2 min)

10°C/min

200°C.

Step-by-Step Identification Workflow

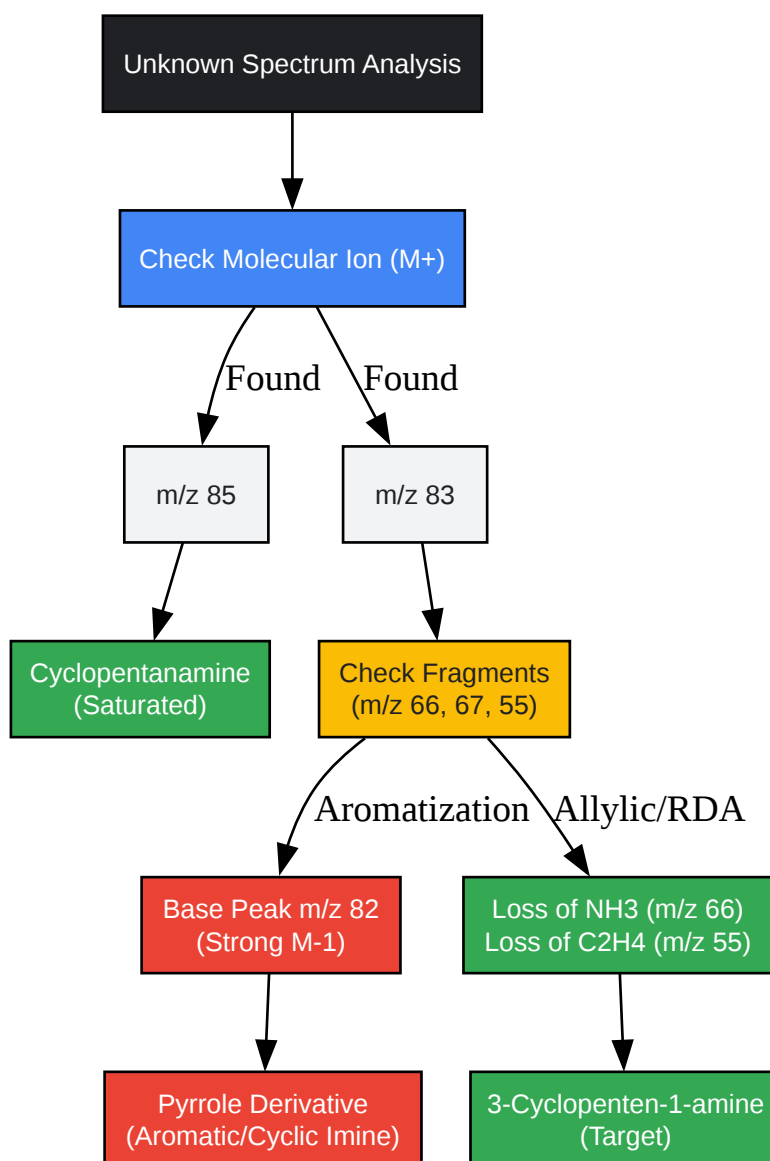

[Click to download full resolution via product page](#)

Caption: Figure 2. Decision tree for differentiating 3-cyclopenten-1-amine from saturated and aromatic isomers using EI-MS data.

References

- NIST Mass Spectrometry Data Center. Cyclopentanamine Mass Spectrum. [1][2] NIST Chemistry WebBook, SRD 69. [1][3][4][5] Available at: [\[Link\]](#)
- McLafferty, F. W., & Tureček, F. (1993). [1][6] Interpretation of Mass Spectra (4th ed.). [1][6] University Science Books. (Standard text for RDA and alpha-cleavage mechanisms).

- Gross, J. H. (2017).[1] Mass Spectrometry: A Textbook. Springer.[1] (Reference for fragmentation of cyclic alkenes).
- PubChem.**Cyclopent-3-en-1-amine** Compound Summary. National Library of Medicine.[1] Available at: [[Link](#)]

Need Custom Synthesis?

BenchChem offers custom synthesis for rare earth carbides and specific isotopic labeling.

Email: info@benchchem.com or [Request Quote Online](#).

Sources

- 1. Cyclopent-3-en-1-amine | C₅H₉N | CID 2756396 - PubChem [pubchem.ncbi.nlm.nih.gov]
- 2. Cyclopentanamine [webbook.nist.gov]
- 3. 2-Cyclopenten-1-one, 3-methyl- [webbook.nist.gov]
- 4. 1-Cyclopenten-1-amine,N,N-dimethyl- [webbook.nist.gov]
- 5. 3-Cyclopentylcyclopentene [webbook.nist.gov]
- 6. thiele.ruc.dk [thiele.ruc.dk]
- To cite this document: BenchChem. [Comparative Guide: Elucidating the Fragmentation Dynamics of 3-Cyclopenten-1-amine]. BenchChem, [2026]. [Online PDF]. Available at: [<https://www.benchchem.com/product/b3050663/docs#comparative-guide-elucidating-the-fragmentation-dynamics-of-3-cyclopenten-1-amine>]

Disclaimer & Data Validity:

The information provided in this document is for Research Use Only (RUO) and is strictly not intended for diagnostic or therapeutic procedures. While BenchChem strives to provide accurate protocols, we make no warranties, express or implied, regarding the fitness of this product for every specific experimental setup.

Technical Support: The protocols provided are for reference purposes. Unsure if this reagent suits your experiment?

Need Industrial/Bulk Grade? [Request Custom Synthesis Quote](#)

BenchChem

Our mission is to be the trusted global source of essential and advanced chemicals, empowering scientists and researchers to drive progress in science and industry.

Contact

Address: 3281 E Guasti Rd
Ontario, CA 91761, United States
Phone: (601) 213-4426
Email: info@benchchem.com

[Contact our Ph.D. Support Team for a compatibility check](#)